

HAMTRONICS® CWID-2 MODULE: ASSEMBLY, INSTALLATION, & MAINTENANCE

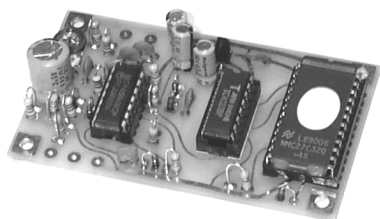

FUNCTIONAL DESCRIPTION.

The CWID-2 is a miniature module for generating Morse code identification for radio repeaters, radio beacons, and similar applications. It provides an audio output tone of adjustable level, normally to a compatible COR board in a repeater, which mixes the tone in with the receive audio for application to a transmitter.

The CWID-2 offers many advantages over the old popular CWID module it replaces. It uses very low current consumption CMOS logic; current consumption is only 3 mA. An EPROM, factory programmed by computer, is used in place of the older diode matrix to reduce assembly time, eliminate sources of wiring errors, and allow longer messages. Many adjustments have been eliminated and replaced by preset circuits for ease of installation; however, resistor values can be modified to make changes if desired. The CWID-2 is less than 1/4th the size of the earlier CWID module, draws 1/60th the current, and costs less, too!

FEATURES

Adjustable output level up to 700 mV p-p.
Ground pulse to trip, easily be adapted for logic hi trip input.
Messages up to 2048 bits – enough for up to 200 characters.
Convenient solder terminals for all connections
+5V logic ID KEY output to key COR board.
Can repeat message continuously for beacon operation.
Power consumption: 7-15V @ only 3 mA.
Size: 1-3/4 x 3-1/8 inches.

ASSEMBLY.

Construction Methods.

Assembly is relatively straight forward. Use the parts list and component location drawing as guides. During construction, orient the board right side up as shown in the component location diagram. The top is the side *without* the "Hamtronics" logo.

Precautions.

Note that the ic's are static sensitive. The warranty does not cover static damage; so handle them with care. Leave them in their protective carriers until assembly is done; and then plug them in, using suitable static handling precautions. A grounded wrist strap should be worn whenever cmos parts are handled. Even after assembly, it is possible to damage cmos parts if static builds up from walking or sliding a chair on a carpet, etc. Always use precautions when handling a board with cmos parts.

The EPROM is light sensitive; excessive exposure to sunlight or even strong room light eventually may erase the chip. Normally it is not necessary; but if you expect the chip to be exposed to strong light, cover the window on the EPROM with a sticker of some sort.

The pc board uses plated-through holes; so only the bottom of the board needs to be soldered. Because it is more difficult to remove parts from plated-through holes, be sure parts are correct before soldering. Traces are close together; so use a fine tip on the soldering iron.

Assembly Procedure.

a. Install ic sockets. All sockets should have notch pointing toward top of board. Solder leads carefully to prevent solder shorts.

b. Install voltage regulator U1, orienting as shown.

c. Install potentiometer R4.

d. Install all capacitors, observing polarity on electrolytics.

e. Install all resistors. On vertically-mounted parts, the body of the part is indicated by a circle on the diagram.

f. Install the 6 diodes, observing polarity. The banded (cathode) ends must be oriented as shown.

g. Check over construction to be sure all parts are installed in proper places, with proper polarities, and check solder connections for any cold solder joints, solder splashes, etc.

h. Using suitable static protection described earlier, carefully unpack the ic's and install them in the sockets. Be sure to orient them with notches pointing up. If any conflict between

notches and dots on an ic, the notch (which only appears on one end) takes precedence.

Be careful that all the pins actually go into the sockets. It is easy for some to bend underneath or extend over the outside of the socket. Note that ic's made by Motorola have one extra digit in the part number, e.g., MC14584 instead of 4584.

INSTALLATION.

Mounting.

The CWID-2 module has holes in the four corners to accommodate 4-40 mounting screws. Normally, threaded aluminum standoffs (not supplied) should be used to mount the board to the repeater chassis to provide a ground connection.

Wiring.

The CWID-2 board uses plated through holes, and the terminal pads around the edge of the board are specially designed to allow easy solder connection of cable harness wires going to the rest of the repeater. The holes are oversized; so the wires can be easily inserted even after the holes are filled with solder.

The easiest way to attach wires is to strip them about 1/4 inch. Then, bend a small "Z" in the end of the wire so that it stays in the hole until soldered. In this way, you can install many wires and solder them all at once.

An alternate method is to preload all the terminal pads with solder. Then, melt the solder at each pad when the wire is inserted. This latter method requires care that solder and flux remains in good condition until the wire is bonded to avoid cold solder joints.

Terminal Functions.

Following is a general description of the function of each terminal, along with expected signal voltages.

Terminal E1 is the input terminal for +7 to 15 Vdc from the power supply.

Terminal E2 provides a ground connection to the board. If the board is mounted to the chassis with metal standoffs, a separate ground connection at E2 is not required.

Terminal E3 provides the audio to

the COR module in the repeater or to the microphone input of the exciter for installations other than a repeater, such as a beacon station. The output of the CWID-2 module is filtered to provide a sine wave signal, and potentiometer R4 allows the level to be adjusted from 0 to about 700 mV p-p. Your COR module may also have a level control.

For some applications, you may want to install a resistor in series with the audio output to reduce the level so audio level potentiometer R4 does not have to be turned down close to the end stop. This would be necessary only in applications where the exciter or other target module required a very low audio input level.

Terminal E4 is the input for the ID Trip signal from the COR module. This should be a ground pulse to trip the id cycle. In a typical COR module, such as our COR-3, this ground pulse is generated right after the courtesy beep. The CWID-2 module has a timer, and the id occurs only when the timer expires, even if the ID Trip signal is applied. Therefore, although the ID Trip signal is applied each time the repeater receiver squelch closes, the id is generated only once every 9½ minutes and only when there is activity on the repeater.

Terminal E5 is the ID Key output from the CWID-2 module when the id is running. This is a +5V logic level, which is applied to the COR module to keep the transmitter keyed when the id occurs.

Terminal E6 is used only for testing. Applying a ground to E6 forces the id, regardless of the state of the timer.

EPROM.

EPROM U4 is light sensitive. Excessive exposure to sunlight or even strong room light eventually may erase the chip. Normally it is not necessary; but if you expect the chip to be exposed to strong light, cover the window on the EPROM with a sticker of some sort.

We can provide a replacement EPROM, programmed with any message you want, for \$30. If you need to order, please specify clearly how it is to be programmed, and specify that it is for model CWID-2.

BEACON STATION OPTION.

Spaced Beacon Mode.

To allow the module to be used to

generate an id each time the timer expires for a beacon station, simply wire ID Trip terminal E4 to permanent ground (instead of a ground pulse). The interval between id transmissions can be adjusted by changing the value of R12/R13 as described later.

Note that, since the id is initiated by the normal reset signal, the first id will not occur until after the first timer period expires (approx. 9½ minutes).

If you want to keep the carrier on the air only during the periodic id, the ID Key logic output signal on E5 can be used to turn on a small signal npn transistor, which can turn on a larger pnp transistor to switch the B+ for one stage of the exciter.

Continuous Beacon Mode.

To make the cwid repeat continuously, with no pause between id's other than that ordinarily programmed in eprom, disconnect CR3. That disables the timer. Then, remove R10.

Carrier Keying Instead Of Audio Tone.

The beacon operation described above assumes you are using the keyed audio tone output to modulate the transmitter. If you need to key the carrier instead, the dc data output signal at the junction of R2, C5, and CR2 can be used to key a switching transistor on and off. This signal should be applied to the base of small npn transistor with the emitter tied to ground. The collector can be used to key another larger pnp transistor to key the B+ to one stage of the transmitter. If you wish, U2-A can be used as a buffer if R3, C6, and C7 are removed.

ADJUSTMENTS.

General Information.

In the interest of keeping the module small and easy to install, there is only one adjustment pot on the board, audio output level control R4. All other parameters are preset by fixed component values. However, there are provisions to change all of the parameters if the default conditions are not suitable for your application.

Cw Tone.

The cwid tone, generated by audio oscillator U2-A, may be adjusted by changing the value of either R3 or C6. Making either value larger lowers the tone, and smaller values raise the

tone frequency.

Cw Speed.

Cw speed is fixed at about 15 wpm, which is the speed most commonly used on repeaters. The speed is determined by R1/C4 in clock circuit U2-F. If you prefer a speed a little slower, you can increase the value of R1, and you can decrease the value of R1 to speed up the code.

Cw Interval.

The length of time between id's is determined by cwid interval timer U2-D, and it is normally about 9½ minutes. The interval is set by R12/R13/C11. Two resistors are used in series to make it easier to change in small increments. The interval may be made shorter by decreasing the value of resistance, and may be made longer by increasing the resistance. However, there is a practical limit to how much resistance is used to lengthen the time period. Too much resistance might result in the timer never timing out because the resistance is larger than the leakage resistance in the electrolytic capacitor. If you need a very long time period, you may need to change to a tantalum capacitor.

THEORY OF OPERATION.

Refer to the schematic diagram.

The cwid sequence is controlled by timer U2-E, inverter U2-D, and latch U2-B/C. When a ground pulse is applied to U2-D through E4 and R7, the inverter responds by setting the latch unless the timer has not timed out. If the timer is still running, a logic hi is applied through CR3 to prevent the latch from being set.

Timer U2-E normally has a logic hi output while running and its output goes lo when the timer has completed its time sequence, which normally takes about 9½ minutes. The time interval is controlled by the time constant of R12/R13/C11. When the time sequence begins, C11 starts charging up slowly through the resistors. When the voltage reaches the threshold at which U2-E turns off, U2-E flips to the "ready" state and stays there until after the id message is played back. Then, at the end of the message, the latch is reset, and capacitor C11 is discharged quickly through R11 and CR4 to await a new playback cycle to be tripped. While the latch is set, a logic hi is applied

through the ID Key output at E5 to the COR board to hold the transmitter on the air.

EPROM U4 is organized as 8 bits x 4K. We only use bits 0 and 7. The cw message is stored as sequential Morse code elements on bit 0 of each byte. Bit 7 is used to reset the cwid run enable flip-flop at the end of the message.

The cwid message is recorded in the EPROM as a series of logic hi's and lo's on bit 0 of each byte of memory. Bit 7 is normally lo and has a logic hi on several bytes after the end of the id message to reset the timer. The counter is reset to the first address by the latch when the id sequence begins. The sequencing of the eeprom message is controlled by ripple counter U3, clocked by U2-F.

The cw tone is generated by audio oscillator U2-A, using R3 and C6 to set the tone frequency. The cw message, in binary form, is used to key the id tone by blocking oscillation through CR1 when the logic level is lo. The cwid tone from the oscillator is a square wave, but it passes through a low-pass filter (R5/C8/R6/C9), which converts the square-wave signal to almost a sine-wave.

Up to 2048 bits of cw data can be stored in the utilized address range of A0-A10. The limit on the length of the message which this much memory will accommodate depends on the Morse code elements needed for each character, but it

is approximately 200 characters.

TROUBLESHOOTING.

Procedures.

The best way to troubleshoot is to trace signals from stage to stage to check the operation of each circuit, starting with the function you believe is not working properly.

Digital circuits have signal levels near ground for a lo logic level and near +5V for a hi logic level. On the schematic diagram, a small pulse symbol next to the line indicates if the signal goes hi or lo during the active condition. This helps to keep the sense of the signal clear in your mind as you glance through from one circuit to the next.

The most common troubles in all kits are interchanged components, cold solder joints, and solder splashes. Another common trouble is blown ic's due to reverse polarity or power line transients.

Current Drain.

Current drain is relatively low, only about 3 mA. If the module is drawing a relatively large amount of current, one or more ic's may have been damaged. If any of the ic's are quite warm or hot, they may be damaged (by a

transient, reverse polarity, etc.)

CWID-2 PARTS LIST.

Ref Desig	Description	(marking)
C1-C2	47µf electrolytic	
C3	.01µf disc	(103)
C4	1µf electrolytic	
C5	.01µf disc	(103)
C6	.0022µf (2n2K or 2.2nK)	
C7-C9	.01µf disc	(103)
C10	.001µf (102, 1nM, or 1nK)	
C11	470µf electrolytic	
CR1-CR6	1N4148 silicon diode	
R1	27K	
R2	100K	
R3	2 meg	
R4	20K or 22K trim pot	
R5-R7	27K	
R8	510K	
R9-R10	27K	
R11	1.2K	
R12	510K	
R13	1 meg	
U1	78L05 voltage regulator	
U2	4584B schmitt trigger hex inverter	
	Ⓢ static sensitive	
U3	4020B binary ripple counter	
	Ⓢ static sensitive	
U4	27C32 eeprom	
	Ⓢ static sensitive	

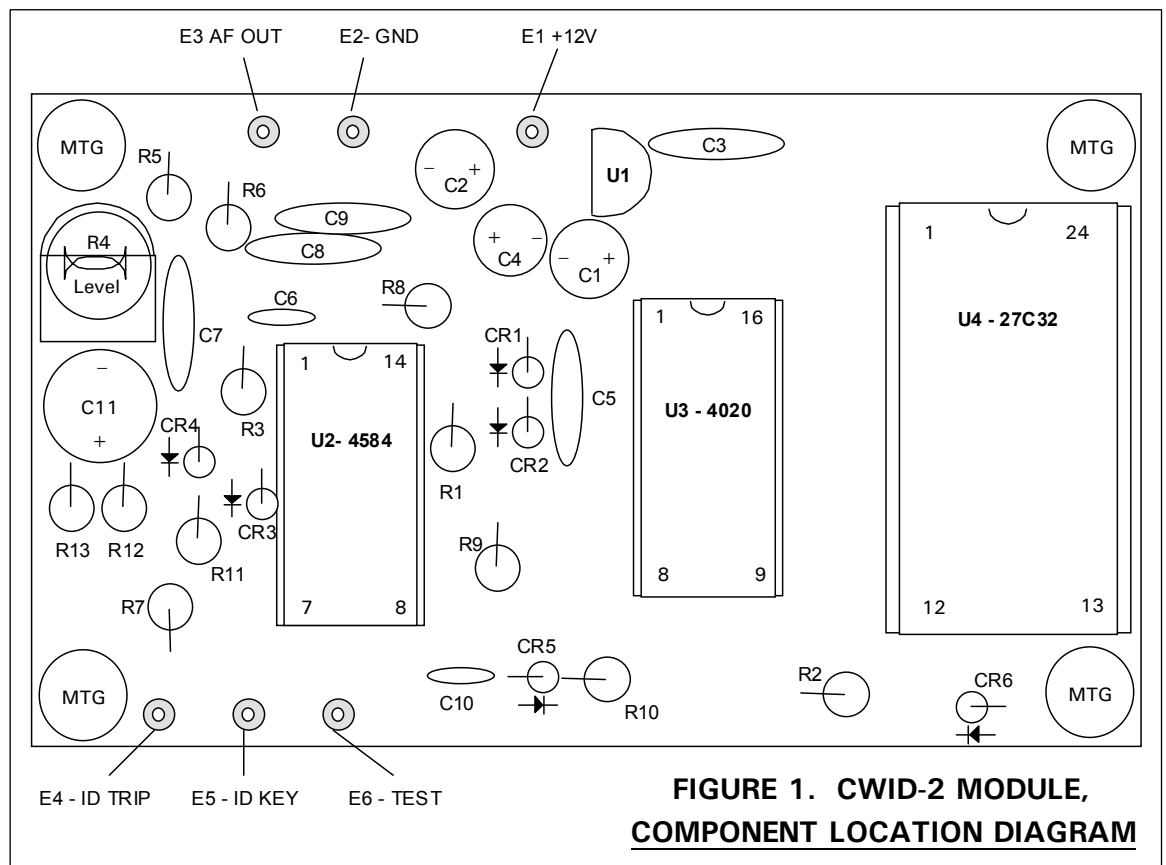

FIGURE 1. CWID-2 MODULE, COMPONENT LOCATION DIAGRAM

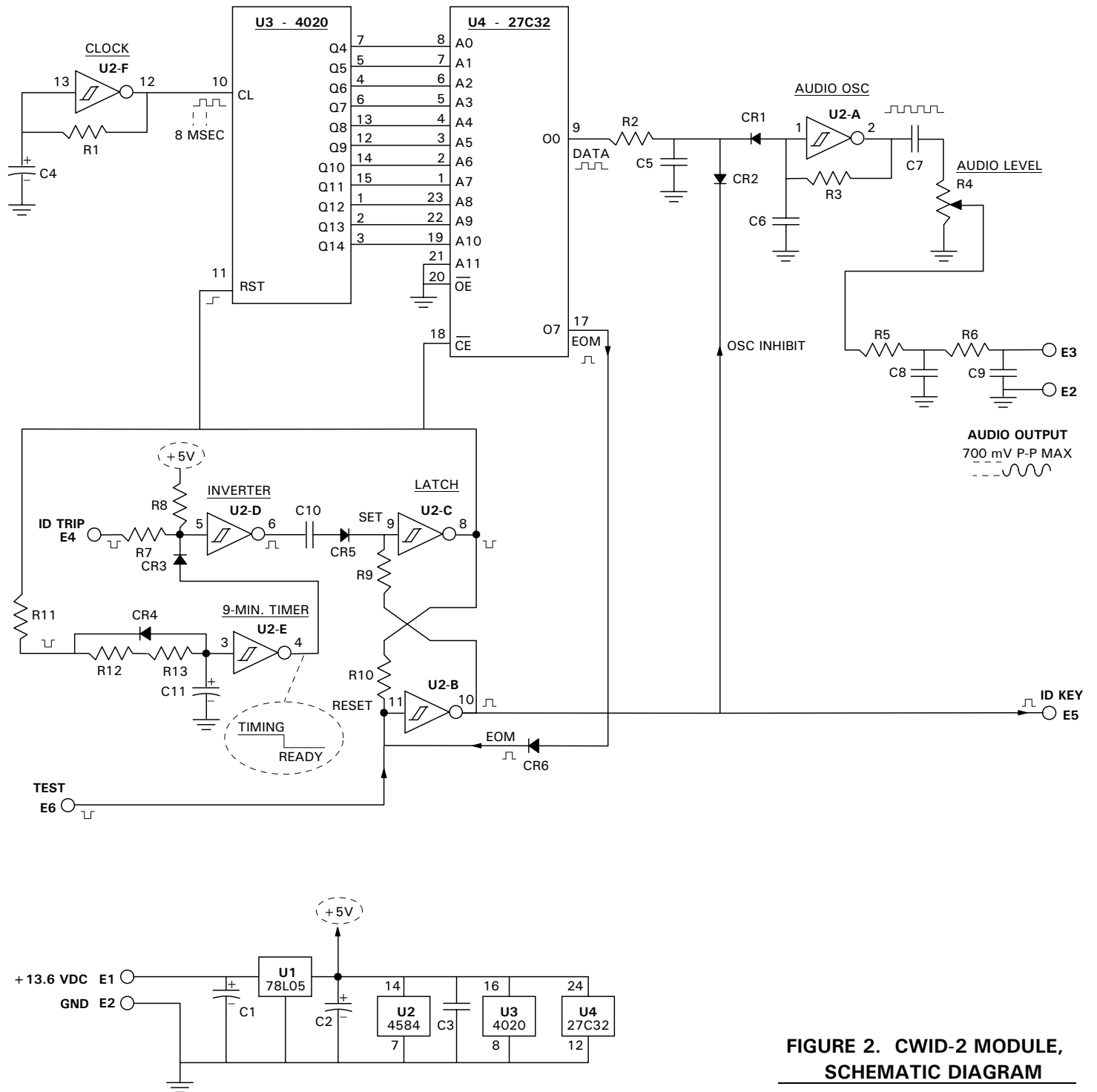

FIGURE 2. CWID-2 MODULE, SCHEMATIC DIAGRAM