

# HAMTRONICS® DVR-1 DIGITAL VOICE RECORDER ASSEMBLY, INSTALLATION, AND OPERATION

## TABLE OF CONTENTS

GENERAL INFORMATION.....	1
Functional Description.....	1
Enhancements.....	1
Recording Quality.....	2
ASSEMBLY.....	2
Construction Methods.....	2
Using the DVR-1 with COR-4.....	2
Precautions.....	2
Assembly Procedure.....	2
INSTALLATION.....	3
Mounting.....	3
Wiring.....	3
Installation with COR-3 Board.....	3
Installation with COR-4 Board.....	3
Generic Repeater Installation.....	3
OPERATION AS ID'ER.....	4
General.....	4
Audio Level Adjustment.....	4
Recording Technique.....	4
ID Interval.....	5
OPERATION AS CONTEST ANNUNCIATOR.....	5
OPERATION AS RADIO NOTEPAD.....	5
ENHANCEMENTS.....	5
General.....	5
Frequent Message Recording.....	6
External Audio Source.....	6
Monitor Speaker.....	6
Battery Operation.....	6
Changing Tone.....	6
Changing Timer Length.....	7
Operation As A Beacon: Repeating Message at Preset Intervals.....	7
Continuous Playback Looping.....	7
Addressing More Than One Message.....	7
Multiple Messages.....	8
Remote Control of Multiple Messages.....	9
Extending Recording Length.....	9
THEORY OF OPERATION.....	9
General.....	9
Recording Technology.....	9
Audio Recording Circuits.....	9
Audio Playback Circuits.....	10
U1 Control Circuits.....	10
S2 Record Switch Circuit.....	10
Q1 Playback Latch Circuit.....	11
Q2 ID Key Circuit.....	11
Timer and ID Trip Circuits.....	11
Q3 One-Shot Stage.....	11
Addressing.....	11
Power Distribution.....	11
TROUBLESHOOTING.....	12
General.....	12
Digital Recorder U1.....	12
Timer U3 and Switching Transistors.....	12
Power Supply Circuit.....	12
PARTS LIST.....	13

## GENERAL INFORMATION.

### Functional Description.

The DVR-1 is a versatile pc board module, which is designed primarily as a voice id'er for repeaters. It may also be used as a general-purpose audio recorder for applications such as a contest CQ caller or a radio notepad to record up to 20 seconds of something important you want to capture, such as the call letters of a station during a contest.

There is another version of this product, called the DVR-2, which is a special version adapted for use with the microcomputer-driven COR-5 Controller in the REP-200 Repeater. That model has its own instruction manual. If you have purchased this unit for use with an REP-200 Repeater, call to arrange for exchange for the proper model and possible update of the firmware eeprom necessary for the repeater.

The DVR-1 module is based on the ISD-1020A chip, using direct analog eeprom technology. The recording is good speech quality, equivalent to what you would expect using a cassette tape recorder. The solid-state recording lasts ten years or more and requires no battery backup.

Included in the DVR-1 are the necessary logic and timer circuits for interface with various COR boards.

### Enhancements.

The 20 seconds of recording time normally is accessed all as one unit. However, with the addition of some external addressing switches, the 20 second capacity can be broken up, any way you like, into multiple messages. Although, switching circuitry to do this is not provided, the address line connections are provided, and information on how to add switches to do your own enhancements is given later in the manual.

Other enhancements may be added to suit your application. With a few changes, you can make the message repeat periodically or loop continuously. You can use an external microphone in place of the built-in mic. You can even record audio from other sources, such as a radio receiver.

The DVR-1 has an on-board speaker amplifier to drive a small external speaker. Although this feature normally is not used in conjunction with repeater operation, it is handy for troubleshooting, and may be used for the radio notepad application.

### Recording Quality.

The ISD-1020A is an amazing new ic which implements an entire digital voice recording and playback system in one chip. This brings real voice to the radio community at a previously unheard-of low price. However, we don't want you to expect a one-chip system to sound like a music CD.

Limitations imposed by the restraints of putting everything on one chip result in good communications quality sound, but not hi-fi. There is a little noticeable hiss and a little distortion because of the digitizing and the limited sampling rate imposed by the number of eeprom cells which will fit on a chip. It is definitely real voice, though, and not a synthesized, artificial-sounding voice.

If you want to enjoy the benefits of digital recording technology at an attractive price and are willing to live with less than perfect audio, you will be pleased. We tell you this now because expectations have a lot to do with satisfaction.

## ASSEMBLY.

### Construction Methods.

Assembly is relatively straight forward. Use the parts list and component location drawing as guides.

During assembly, orient the board right side up as shown in the component location diagram. The top is the side with the terminal numbers.

The four labeled holes around the

perimeter of the board are for wires connecting to the COR board.

The five pads at the upper left are for optional address line connections, which are only used if you choose later to enhance operation with multiple messages. For now, disregard these holes; there are no components to install in them.

### Using the DVR-1 with COR-4.

Note that when the DVR-1 is used with the COR-4 controller board, input stage Q3 is not used. The inset at the bottom of the parts location diagram shows alternate connections used when the application includes the COR-4. If you are building the DVR-1 for use with the COR-4, do not install the components represented by the empty pads, and run the top lead of R14 over the upper pad normally used for R15, as shown. If you purchased the unit wired and tested and wish to use it with the COR-4, it will be necessary to modify it as shown.

### Precautions.

*Note that the ic is static sensitive because it uses cmos technology.* The warranty does not cover static damage; so handle it with care. Leave it in its protective carrier until assembly is done; and then plug it in, using suitable static handling precautions. A grounded wrist strap should be worn whenever cmos parts are handled. Even after assembly, it is possible to damage cmos parts if static builds up from walking or sliding a chair on a carpet, etc. Always use precautions when handling a board with cmos parts.

Be careful not to confuse parts marked similarly, such as 150K and 510K resistors. Double check each part as installed. When done, if parts are short and others are left over, go back and check each part to be sure a wrong value didn't get installed somewhere.

The pc board uses plated-through holes; so only the bottom of the board needs to be soldered. Because it is more difficult to remove parts from

plated-through holes, be sure parts are correct before soldering. Traces are close together; so use a fine tip on the soldering iron. All parts should be installed flush with the board.

### Assembly Procedure.

Install and solder the parts in each of the following steps as you proceed.

a. If you intend to mount the DVR-1 board in a repeater chassis or other enclosure, you should use the blank pc board as a template before assembling any components. Set it in place, and mark where to drill the mounting holes. When used in a repeater, the DVR-1 board should be close to the COR board to allow short interconnecting wires to minimize noise on the audio lines. When used with the COR-4 board, the best location is near the left side of the COR-4, near pads E16 and E18, which will be used for interconnections.

b. To begin assembly, in each of the four mounting holes in the board, install a hex standoff with a 4-40 x 1/4 inch screw. Make sure the screw is on the top side of the board, which has lettering on it.

c. Install the two ic sockets on the board, orienting the end with the notch as shown.

d. Install the two pushbutton switches. Note that they fit properly only with the leads oriented toward the left and right, not up and down.

e. Install potentiometer R8.

f. Install ferrite bead Z1.

g. Install all capacitors, observing polarity on electrolytics.

h. Install all resistors. On vertically-mounted parts, the body of the part is indicated by a circle on the diagram.

i. Install the two diodes, observing polarity. The banded (cathode) ends must be oriented as shown (at

### HOW TO CONTACT US —

Hamtronics, Inc.  
65 Moul Rd; Hilton NY 14468-9535  
Phone: 716-392-9430  
<http://www.hamtronics.com>  
email: [jv@hamtronics.com](mailto:jv@hamtronics.com)

bottom of diode and with diode in the hole shown).

j. Install the transistors as shown.

k. Install the microphone on the pc board, soldering the red and black leads to E5 and E6 as shown. Be sure to observe polarity. Note that the microphone is supported simply by its wire leads about an inch over the board. The microphone head can be tilted gently upward so that it faces the user when the cover is off the repeater.

l. Using suitable static protection described earlier, carefully unpack the ISD-1020A ic and install it in the socket. Be sure to orient it with notch as shown. Be careful that all the pins actually go into the socket. It is easy for some to bend underneath or extend over the outside of the socket. Do not bend any of the pins excessively, as they may break from repeated stress.

m. This completes assembly. Check over construction to be sure all parts are installed in proper places, with proper polarities, and check solder connections for any cold solder joints, solder splashes, etc. If any parts are missing, check to be sure that other parts are not left over; since a part may have been installed in the wrong place.

## INSTALLATION. Mounting.

Four mounting holes should have been drilled in the repeater chassis before assembling the DVR-1 pc board. Now, set the board in place as shown below, and secure with four 4-40 x 1/4 inch screws.

*Caution: The digital recorder ic is static sensitive. Use suitable handling precautions, including grounding yourself, to avoid damage.*

## Wiring.

Four #22 hookup wires (not supplied) should be attached to the four terminals identified in the illustration below. Dress the wire leads away

from the DVR-1 board, as shown, and over to the COR board. Twist the leads together to form a neat bundle.

Wiring to the COR board depends on which board you are using. Following are two sets of information for COR boards we manufacture: the COR-3 and the COR-4. Also, generic information is given for use with any type of COR board for other applications.

It is assumed that the pc board will be mounted to a chassis, from which it will get its ground connection through mounting hardware. If this is not the case, you must provide a heavy ground wire to the ground plane on the board.

### Installation with COR-3 Board.

a. Begin by removing any connections to a cwid board from the COR-3.

b. Connect +13.6 Vdc to B+ input pad E4 on the DVR-1.

c. Connect ID TRIP pad E2 to terminal E9 in the upper right-hand corner of the COR-3 board. Remove C4 on the COR-3 board, and replace it with a jumper wire.

d. Connect ID KEY pad E3 to terminal E13 on the COR-3 board.

e. Connect AUDIO output pad E1 to terminal E4 on the COR-3.

### Installation with COR-4 Board.

a. The best location for the DVR-1 board is near the left side of the COR-4, near pads E16 and E18, which will be used for interconnections.

b. Check to be sure that the DVR-1 was constructed with Q3 stage omitted as shown on schematic diagram and on the inset in the lower right-hand corner of the component location diagram. If necessary, modify the board as shown on the inset. When used with the COR-4, the TRIP signal is applied

to the base of Q4 through resistor R14.

c. Remove U1, U2, U3, and U4 from their sockets on the COR-4 board. These ic's for the cwid circuit are not used.

d. Connect +13.6 Vdc to B+ input pad E4 on the DVR-1.

e. Connect ID TRIP pad E2 to pin 3 of the empty socket for U1 on the COR-4. The preferred method is to tack solder the wire to the pad under the board, but if you are careful and use #22 solid hookup wire, you can push the end of the wire into the socket for pin 3 without removing the COR-4 board from the chassis.

f. Connect ID KEY pad E3 to E16 on the COR-4 board. This provides a direct connection to the base of Q2 on the COR-4 board.

g. Connect AUDIO output pad E1 to E18 on the COR-4 board, a convenient place to connect to the audio line going to the exciter.

### Generic Repeater Installation.

There are several ways to connect the DVR-1 audio to a repeater, either to the audio mixer on the COR board or directly to the exciter audio input.

If your COR board has an audio mixer, you can connect the DVR-1 audio output at E1 to the mixer input on the COR board. The DVR-1 puts out about 1Vp-p max. into a high impedance (over 100K) load such as most mixers present.

If your COR board does not have an audio mixer, but it has a relatively

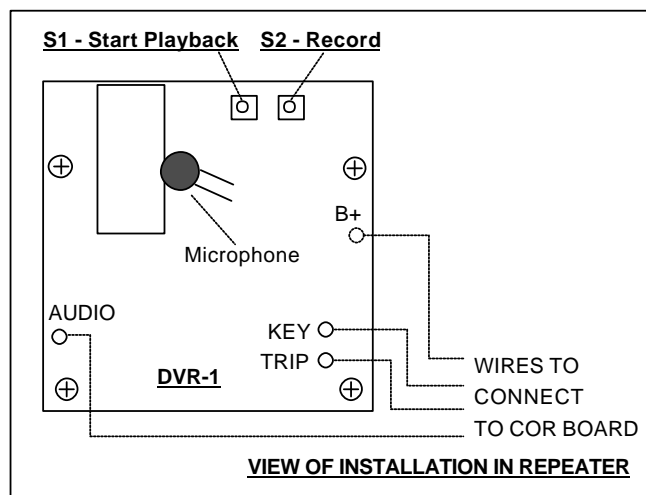

high output impedance (greater than 50K), you may be able to connect the DVR-1 audio output directly to the audio input on the exciter. For example, our COR-3 has a large resistor in series with its audio output and the mic input of our exciter has about a 2K load impedance. The DVR-1 also has a large resistor in series with the audio output circuit; so the DVR-1 could be connected directly to the mic input on the exciter in such a case. If you do this, you can expect the maximum DVR-1 audio output level at the exciter input to be much lower than the 1Vp-p normal open circuit level. For example, with a 2K exciter input impedance as the bottom leg of a voltage divider and 47K resistor in the DVR-1, R9, as the top leg, you can expect about 50mVp-p max. at the exciter.

To trip the id on the DVR-1, the COR board must provide a logic level transition from high to low (something near +5V to something near ground). The best place to try to obtain this in the COR board is at the output of the timer which provides the delay for the courtesy beep, if one is used, so that the id is triggered only after the receiver squelch closes and a short delay allows someone to break in (courteous id).

If you have no courtesy beep, connect to some circuit which goes from high to low after the squelch closes, perhaps the COS line from the receiver to the COR or the switched B+ output of the COR board, wherever you can get a high to low transition. The id TRIP input circuit on the DVR-1 is edge triggered, i.e., it is triggered when the input voltage goes from high to low; it doesn't matter how long it stays high or low, just when the transition occurs. It is important that the circuit which drives the id TRIP input of the DVR-1 be dc coupled to the DVR-1, i.e., no blocking capacitor between it and the input of the DVR-1 other than the capacitor provided in the DVR-1 input circuit.

To key the repeater whenever the id is in progress, the id KEY signal

from E3 on the DVR-1 should be connected to a logic point in the COR circuit which would key the transmitter with a 5V logic signal applied. The DVR-1 has a resistor (R12) in series with the KEY output signal so that it can be applied directly to the base of a

### Audio Level Adjustment.

Audio level pot R8 should be adjusted for desired deviation level on the transmitter.

Note that on a board, such as the COR-3, which has its own id level control, that control also affects the

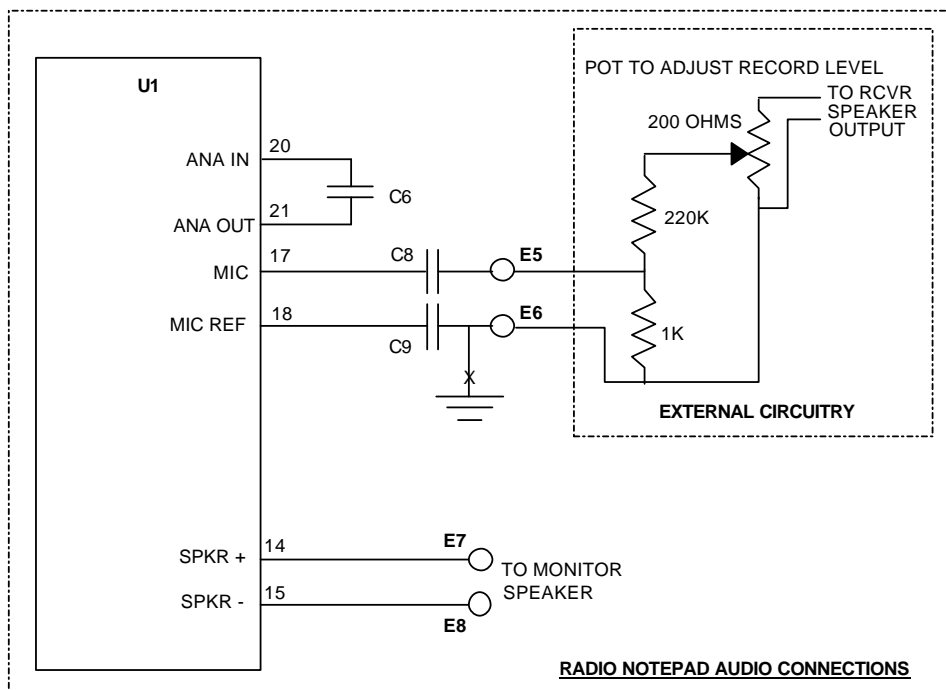

transistor if you like. The amount of resistance needed depends on the amount of current needed to drive the circuit in the COR board. If you are bridging across an existing drive circuit in the COR board, you may need a higher source resistance and so you might want to add more resistance external to the DVR-1.

### OPERATION AS ID'ER.

#### General.

To record, just press RECORD switch S2 and speak into on-board microphone. Be sure to allow a second or two after pressing record switch before speaking, and allow about 1 second after the end of your message before releasing the record switch. This will allow for smooth transition between carrier turn on and id message. Total recording time is 20 seconds.

To playback for testing, momentarily depress START PLAYBACK switch S1. Repeater is keyed automatically while message is running.

audio level. In such cases, it is best to set the control on the DVR-1 to full clockwise, and use the adjustment provided on the COR board.

When used with the COR-4 board, if you cannot adjust the audio level for high enough deviation, you may need to change the value of R9 on the DVR-1 board to 22K or less to allow sufficient adjustment range.

You can set the voice id level for ±5 kHz deviation if you like; however, you may wish to set it a little lower than normal repeat audio level, both to keep the id soothing and to minimize distraction from any noticeable distortion or hiss which the recording may have. (It is normal for this digital recording system to have a slight amount of distortion and hiss, but it should be no more objectionable any more than a tape recording.)

#### Recording Technique.

Some practice will be necessary in order to find the best distance to be from the microphone and how loud to speak in order to maximize intelligibility and minimize

bility and minimize distortion. For starters, try using a slightly louder than normal voice in order to enhance diction and enunciation and try a distance of about 12 inches from the microphone.

### **ID Interval.**

The DVR-1 has a timer (U2) which determines how often the id will occur. It is set to id about every 9 minutes, but only id's when there is activity. If you wish to change the id period for some reason, you can change the value of R15. Increasing the value will lengthen the time and decreasing it will shorten the time. However, there is a practical limit to how long a time you can set. Generally, trying to increase the time much over 15 minutes would make the circuit unreliable.

The id is courteous; i.e., it will not occur while someone is talking on the repeater. This is a function of the COR board which provides the trip signal and assumes that you are using the COR-3 or COR-4, which provide a courteous id trip signal (only after the receiver squelch closes).

### **OPERATION AS CONTEST ANNUNCIATOR.**

The DVR-1 is handy for use during a contest or in working dx to substitute for the microphone when you want to repeatedly say the same thing on the air, such as calling CQ.

For such an application, you should mount the DVR-1 in a small enclosure with two pushbutton switches and an audio output jack. Some form of power will also be required, either a 12V power supply or a battery.

The pushbutton switches will substitute for the small switches on the DVR-1 pc board, and the audio output of the DVR-1 should be wired through a jack to allow it to be easily plugged into or switched into the mic jack on the transceiver. The audio level control on the DVR-1 should be adjusted for the proper level once, and it can be left alone; therefore, it need not be

extended to allow external operation.

The TRIP input and KEY output pads on the board normally are not used in this application. However, you could use the KEY output to key the transmitter if you found that convenient.

You may also be interested in the techniques described in the Looping and Beacon mode sections described later in the manual.

### **OPERATION AS RADIO NOTEPAD.**

The DVR-1 may be used to record up to 20 seconds from any audio source. One of the interesting applications is to have a DVR-1 mounted in a small enclosure with power applied and standing by to record the receiver audio of your transceiver or other source whenever you suspect you might want to review what was said. For example, you might want to record the call letters of a rare dx station you hear or the call letters of a station heard during a contest.

If you have the DVR-1 rigged up with an audio input jack connected to the audio of your receiver and a small speaker connected to the speaker output of the DVR-1, you can record anything just by quickly pushing a RECORD switch mounted on the enclosure.

After it is recorded, you can then hit the START PLAYBACK switch to play back the recorded message for review. It can be played back repeatedly, until you understand the message, simply by pressing the PLAYBACK switch repeatedly.

For such an application, you should mount the DVR-1 in a small enclosure with two pushbutton switches, an audio input jack, an input level control, and a small 16-ohm speaker. Some form of power will also be required, either a 12V power supply or a battery. The pushbutton switches will substitute for the small switches on the DVR-1 pc board. For more information on speakers, see the Monitor Speaker paragraph in the Enhancements section, later in the

manual.

The diagram below shows how to connect the DVR-1 microphone input to the speaker output of a receiver, using a few external components. The potentiometer and resistive voltage divider reduces the audio level to the 20 mVp-p range required for the microphone input.

The TRIP input and KEY output pads on the board normally are not used in this application.

If you will be busy when the event occurs which you want to record, you can trap the recording with minimum attention on your part if you use a toggle switch in place a momentary switch for the RECORD switch. Flip it on to start recording and flip it off anytime later. The ic quits recording when the 20 seconds is up; so it doesn't matter if you leave it on for a few minutes. When you playback, it automatically stops when the memory ran out after 20 seconds.

### **ENHANCEMENTS. General.**

This section of the manual provides information on some modifications which can be done to allow the DVR-1 to be used in some other applications. Some of these are rather involved and require a good background in digital electronics to accomplish. We recommend that you only tackle them if you feel your background is sufficient, and even then, you should operate the unit in its standard setup as designed before attempting any modifications so it will be easier to solve problems which may occur.

The Theory Of Operation section gives some additional explanation of the operation of the recorder ic, which may allow you to do some other adaptations. If you develop an application you want to share with others, we invite you to let us know. If we can, we'll add it to the manual to make it available to future DVR-1 users.

## Frequent Message Recording.

If the DVR-1 board is installed in an awkward place, such as under a repeater chassis or in a covered compartment, access to the record switch and microphone may be inconvenient. If you are going to change the message more than once or twice a year, you may want to install a connector to allow use of a push-to-talk hand-held microphone. Almost any electret or low-impedance dynamic microphone can be used. Here are some things which should be considered when an external microphone is used.

The microphone input at U1 pin 17 has a sensitivity of 20 mVp-p and a 10K input impedance. This is ideal for electret type microphones.

Automatic gain control provides about 20dB of compression range to compensate for various microphone characteristics and speech volumes. If the audio level from the microphone is too great, distortion will occur.

If you use an electret microphone, you may need to experiment with the value of mic bias resistor R7 to find a value which gives best level and lowest distortion with your microphone.

If you use a low impedance dynamic microphone, bias normally is not required; so R7 should be removed from the board.

The input amplifier is a differential op amp, and pin 18 of the ic is the inverting input. It provides a noise canceling or common mode rejection input to the mic amplifier. This input is coupled through a coupling capacitor, identical to the one used for the

mic input, to the ground return used for the microphone. The use of this noise canceling input gives about a 10 dB improvement in recording noise level, and it is important for reducing any noise which might otherwise be picked up from the digital circuitry.

If you extend the input for an external microphone, you should try connecting this mic reference line to the point at which the ground is picked up for the microphone, e.g., at the front panel microphone jack on a repeater. If the mic reference line is extended in this way, you should break the pcb trace which connects E6 to the ground plane on the pc board at the point noted on the component location diagram.

## External Audio Source.

If you need to connect an audio source other than a microphone to the input of the DVR-1, any source of 20 mVp-p can be used. Refer to information earlier in the manual for the Radio Notepad application for ideas.

You can also apply audio directly to the analog input at U1 pin 20, which bypasses the agc amplifier and thus requires manual adjustment of exact record level. The sensitivity of this input is 50 mVp-p. To use that input, C6 must be disconnected at U1 pin 21 and used as a blocking capacitor in series with the input audio.

## Monitor Speaker.

A small 16Ω speaker can be connected to E7 and E8, which are resistor leads. This feature may be handy

for troubleshooting and for applications such as the Radio Notepad described earlier. The DVR-1 can deliver about 75 mW of audio into a 16 Ω speaker, which should be sufficient in a quiet room. If you have a speaker of lower impedance, a resistor should be added in series with the speaker to increase its impedance to 16Ω. If you need a louder speaker, the output of the DVR-1 can be connected to an external amplifier.

## Battery Operation.

The DVR-1 has a built-in 5V regulator to allow operation from 12V power supplies. If you want to operate from a low voltage battery, the most convenient way to do it is by using a small 6V dry cell battery with a diode, such as a 1N4148, in series to reduce the voltage to about 5V. Do not apply more than 5.5V to the circuitry in the DVR-1 to avoid damage. The current drain is about 30mA at idle and about 48mA during playback.

## Changing Tone.

The bass response of the recording circuit is controlled largely by the values of C8 and C9. Depending on the microphone you use, you may want to increase the values of these capacitors to get more low frequency response or decrease them for less low frequency pickup. Both capacitors must be the same value. If you want to increase the value, it may be necessary to change to a different type of capacitor, such as polyester (mylar) capacitors, in order to get a large value.

## Changing Timer Length.

The time period of timer U3 is set by the time constant of R15 and C16. It is preset at about 9 minutes, which is normal for repeater id operation. Increasing either proportionately will increase the length of time and vice versa. However, there is a practical limit to the maximum length of time. If either value gets too large, the leakage resistance of the capacitor will be low enough relative to the resistance of R15 that the capacitor will not fully charge and the timer will be unreliable. If you want to make the timer take longer than 10 minutes, consider using a very low leakage type of capacitor. If you want to make the time adjustable, you could substitute a potentiometer for R15.

## Operation As A Beacon: Repeating Message at Preset Intervals.

The following method may be used to make the DVR-1 repeat its playback message periodically, as would be done for a beacon transmitter or similar applications. The interval at which the message repeats is controlled by timer U3, which uses the time constant of R15 and C16. See *Changing Timer Length, above*.

Refer to schematic diagram. Remove Q4 from the pc board, and install a jumper from emitter to collector pads so the output of timer U3 is connected directly to START PLAYBACK switch S1. Then, when you initiate playback by pressing S1, the message is played; and at the end of the message, timer U3 is reset by the End of Message line at U1 pin 25. The timer output will go high during the timer interval, allowing the message to stop until the timer period expires, at which time, message playback is initiated again when the timer output goes low. The message playback cycle will continue this way until power is turned off.

## Continuous Playback Looping.

A special operational mode can be used to accomplish continuous looping of the message without using the timer. In this case, the message

would repeat as soon as it ends, and continue until power is turned off. Two conditions are necessary in order to use this mode: the message must begin at address zero (the normal way the unit is wired unless you are using multiple addresses), and the message must not run over the end of the 20 seconds of storage space (the recording must be less than 20 seconds long).

To use this mode, a message is first recorded with all the address lines tied low. This positions the message at the beginning of the address space in the ic. Next, the ic is put into "Repeat Operational Mode" by tying address lines 3, 6, and 7 high. Use a toggle switch in place of S1 so you can enable continuous playback and not have playback stop at the end of the message. As long as S1 is closed to ground, the message will repeat from the beginning automatically.

The address lines are accessible at pads on the upper left side of the DVR-1 pc board. There are five pads, labeled A3-A7, which are each connected to ground by traces on the top of the board. The ground traces must be broken on the board for the three address lines to be used: A3, A6, and

Address Pads	A7	A6	A5	A4	A3
Weight (sec.)	16	8	4	2	1

A7.

You can use a toggle switch to change address lines from low to high. Jumper those three address lines together and connect them to the center terminal of a spdt toggle switch. Connect one of the end terminals on the switch to ground (at the ground trace along the edge of the board) and the other end terminal to +5Vdc (at the right hand lead of ferrite bead Z1).

You can mark the position of the switch which provides a ground signal "Record" and the position which provides +5Vdc "Playback Repeat".

If you leave the toggle switch in the "Record" position (ground connected to the address lines), you can press START PLAYBACK switch S1 and have the message play back only once. If you set the toggle switch to "Playback Repeat" position and press S1, you will have continuous playback.

## Addressing More Than One Message.

The rest of the enhanced opera-

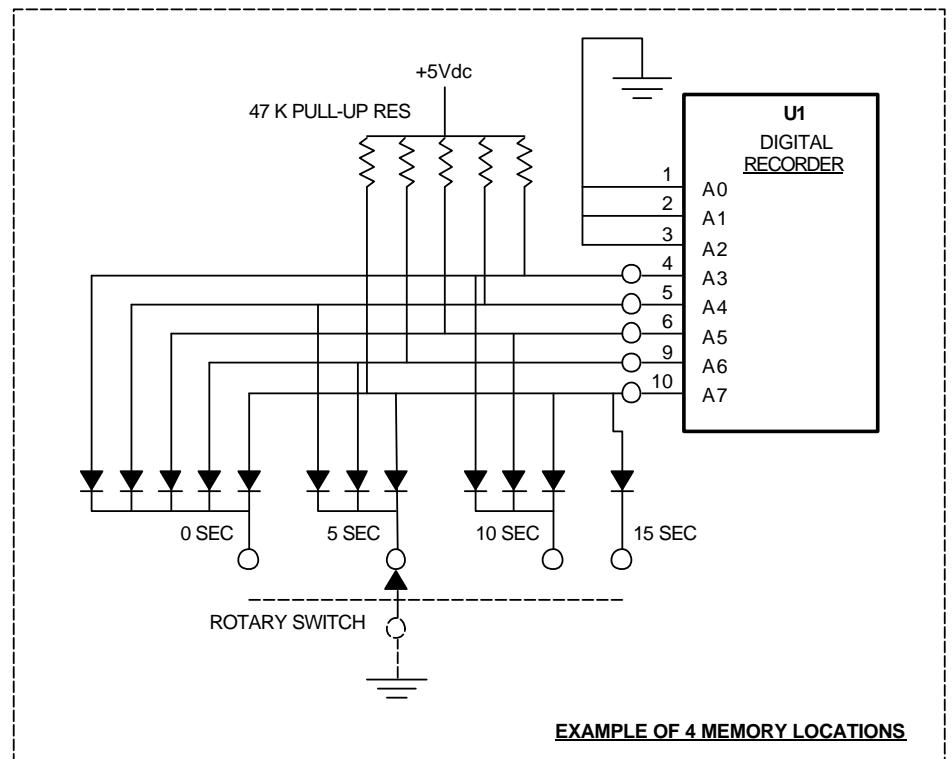

tion techniques all depend on the user having a good grasp of binary addressing. You should not attempt any of these modes unless you feel comfortable with the discussion that follows.

The ISD1020A ic can be operated in many different modes. The simplest is the "addressed" mode, in which the various 8-bit address lines marked "A0" through "A7" on the schematic diagram are used to set binary addresses for the starting points of various message storage areas in the chip.

The 1020 ic can be looked at as a miniature tape recorder with 20 seconds worth of tape. It has the ability to pre-position the playback/record head anywhere on this 20 second tape before we begin operation. The device has 160 valid addresses giving an address resolution of 0.125 seconds. This means 8 address counts equal 1 second of record time.

To determine what address to give the device, we must first convert seconds into binary counts. A 1-second resolution is adequate for our purposes. Since 8 counts equal one second and 8 is an even binary multiple, we can ignore all the counts less than eight. We do this by strapping A0, A1, and A2 to ground and just programming the 5 remaining bits. Using switches and diodes (for isolation), we can select any interval between 1 and 19 seconds for the start of record or playback.

To program addresses, we need to tie individual address lines to ground (logic 0) or +5Vdc (logic 1). Table 1 gives the binary address weight of each address line pad on the pc board.

Using normal binary numbering to do the addressing, following are examples to illustrate how to program at one second intervals. Not all addresses are given, only enough to give you the idea of how binary digits are added to yield the desired address.

Note that the address is the starting address of either record or playback message and must be set before the RECORD or START PLAYBACK

switch is pressed. Because we are addressing in one-second increments, the highest practical address is 19 seconds.

We mentioned earlier that there are other operational modes besides the addressing mode. These are enabled by tying both A6 and A7 high at the same time, which tells the ic that instead of using message starting addresses, we want the chip to operate in a special mode. These other modes are selected by pulling one of the A3-A5 lines high while the A6 and A7 lines are also high. For instance, tying lines A3, A6, and A7 high selects a special message looping mode, which was discussed earlier. There are other modes which we won't discuss because they are used for testing or in modes not suitable for our type of product. All these operational modes use a message space starting address of zero; the programming in these cases establishes a mode of operation and not the starting address of the message.

### Multiple Messages.

Using addresses, you can record and playback multiple messages, depending on the starting addresses being properly set before record or playback is initiated. When a message is recorded, the recording starts and runs until you release the RECORD switch. At the end of the message, the ic embeds an "EOM" (end of message) marker, which controls where the playback will automatically stop.

Keep in mind when recording a new message that if you record a message longer than the address space you have reserved for it, you will begin erasing the next message in the series (or run over the end of the 20 second capacity of the chip). If you then try to select the message you just erased part of, you will get the end of the new message starting at the message address of the message you just corrupted. *Whenever you play a message, the ic starts at the selected address, whether or not that coincides with the start of a message, and it*

Start Address	Address Pads				
Location (sec)	A7	A6	A5	A4	A3
0	0	0	0	0	0
1	0	0	0	0	1
2	0	0	0	1	0
3	0	0	0	1	1
4	0	0	1	0	0
5	0	0	1	0	1
6	0	0	1	1	0
7	0	0	1	1	1
8	0	1	0	0	0
15	0	1	1	1	1
16	1	0	0	0	0
17	1	0	0	0	1

*runs until it sees an EOM marker. If you want to record a message longer than its allowed message space, just go ahead and do it; but remember that the next message just isn't available any more.*

The schematic diagram below shows how multiple message addressing is implemented in a simple system with four 5-second message spaces starting at 0, 5, 10, and 15 seconds into the recording space. You can easily set up any number of spaces at whatever addresses you want; these are just used as an example. The spaces don't need to be evenly divided as in the case.

The five resistors are used to pull up the address lines to +5Vdc when they are not grounded through the diodes. For simplicity, we depict a rotary switch in a straight line format. Note that any type of switch can be used. The only thing that matters is which lines are grounded *at the start* of a record or playback cycle. It doesn't even matter if you change an address setting in the middle of a cycle; that would be ignored. You can devise any sort of switching scheme you like as long as you set the starting address as defined earlier.

*Remember that the diodes are installed for those address lines that are to be programmed low (ground), not high (+5Vdc). The pull-up resistors provide the logic high voltage for those address lines which are not grounded through the diodes.*



## Remote Control of Multiple Messages.

If you want to be able to control which of several messages is used, and do it by remote control, you can use a unit, such as our TD-2 DTMF Decoder/Controller to select a particular group of diodes, as shown in the schematic for multiple message addressing. Just make sure that you don't turn on remote control latches for more than one address at once or the address will be mixed up.

## Extending Recording Length.

You can cascade more than one unit to record longer than 20 seconds, but it raises the cost, of course. It gets involved, but you can chain the chips together so each one starts exactly where the last one ran out of space. If you have an application which requires a longer recording time, let us know when you order your additional units that you want to chain them together, and we'll find some information for you on how to connect them together.

## THEORY OF OPERATION.

### General.

Following is a thorough discussion of the operation, first of the digital voice recorder ic, and then of the support circuitry. You will need a background in digital electronics to understand some of it, although it isn't too complicated.

## Recording Technology.

The ISD-1020A ic is an analog sampled data system, with on-chip microphone preamp, agc, anti-aliasing and smoothing filters, storage array, speaker driver, control interface, and internal precision reference clock. This system uses eeprom technology to directly record analog signals so no d-a and a-d converters are required.

The 1020A ic uses a sampling rate of 6.4 kHz for 20 seconds of storage time, and it has an anti-aliasing filter which cuts off at 2700 Hz. If the frequency response was higher, the recording time would be less, because at least two samples per cycle are required to reproduce any frequency.

## Audio Recording Circuits.

*Refer to schematic diagram at the rear of the manual and the block diagram of the ic below.* The DVR-1 normally records audio from the electret microphone on the board, but it can also record audio from an external microphone or a line input. R6 and R7 provide dc bias for the microphone, and pin 18 of the ic provides an inverting input to the microphone amplifier which is connected to whatever ground return is used for the microphone in order to cancel any hum or noise pickup. The analog preamp output at pin 21 is coupled through blocking capacitor C6, which also serves to tailor the frequency response to match the microphone.

During recording, the 1020A chip performs several stages of signal conditioning before the actual storage operation takes place. The first stage is the amplification of the input signal to a level optimized for the dynamic range of the storage circuits. This is done by the preamplifier, amplifier, and agc circuits in the chip. Amplification is done in two steps — initially by the input preamplifier and then by a fixed gain amplifier. The signal path between the preamplifier and the fixed gain amplifier is completed by a blocking capacitor, which allows the fixed amplifier to be connected to a line input instead in some applications.

The preamplifier has automatic gain control, with the attack/release time constants set by R10/C12. The 20 dB or so of gain compression range on the preamp compensates for variations in microphone characteristics and levels of speech volume.

The next stage of signal conditioning is done by the input filter. Although analog storage of the instantaneous voice level does not require an a-d converter, digital sampling is done in the time domain; so an anti-aliasing filter is required to limit any speech components to frequencies less than one-half the sampling rate. This is a primary requirement of any digital audio processing technology.

The processed waveform is then passed into the analog transceivers to be written into the analog storage array. Because the storage process takes longer than the sampling period, several samples are written at one time, and then another group of samples is written, and so on. The eeprom cells work similar to digital eeproms you are familiar with, but these eeprom cells actually store an analog voltage and not a digital signal (0's and 1's). The recording is non-volatile; it has a useful life of at least ten years even if no power is applied during part or all of that time.

### Audio Playback Circuits.

During playback, the recorded analog voltages are sequentially read from the storage array, thereby reconstructing the sampled waveform. The smoothing filter on the output path removes the sampling frequency component and the original waveform is restored. The output of the smoothing filter is connected through an analog multiplexer into the output power amplifier. Two output pins provide direct speaker drive capability of about 50 mW rms (100 mW peak) into a 16Ω speaker — enough to be clearly

heard from the other side of a normal sized room. An external audio signal can also be applied to the speaker driver through the AUX IN at pin 11.

### U1 Control Circuits.

There are four control lines used on the ic, plus a test line which we do not use.

The PD (power down) line at pin 24, which is normally held low during record or playback, does two things when raised high. First, it resets the internal address pointer to zero. Second, it puts the ic in a power down state in which it draws very little current (for idling).

The P/R line puts the chip in a playback mode when high and record mode when low.

The CE (chip enable) line is what actually starts each record or playback cycle. It is held low to make the chip run.

The EOM line puts out a low signal under two conditions. First, when the playback mode reaches the end of a recording on the chip, the EOM line puts out a ground pulse of about 25 mSec length. Second, if the chip runs until the very end of its 20 second recording time, the EOM line goes

low and stays low until the chip receives a PD signal to reset it.

### S2 Record Switch Circuit.

Now that you know the functions of the control pins on the U1 chip, we can discuss how the external control circuits operate. Refer to the schematic diagram.

In order to record a message, S2 (or an external switch performing the same function) is depressed. The switch works in conjunction with pull-up resistors R1 and R2 to apply either +5Vdc or ground to the various control pins on the U1 chip. If no switches are depressed, R2 pulls the PR line high and R1 pulls the PD and CE lines high.

When S2 is depressed, all these lines are brought low, which puts the chip in the record mode, powers up all the internal circuits, and makes the record sequence run. At the end of the message, releasing the switch stops the record cycle and causes the chip's internal control circuitry to put an "end of message" marker at the point in memory where the message ends. On playback, this marker controls where playback stops.

Steering diode CR1 allows S2 to

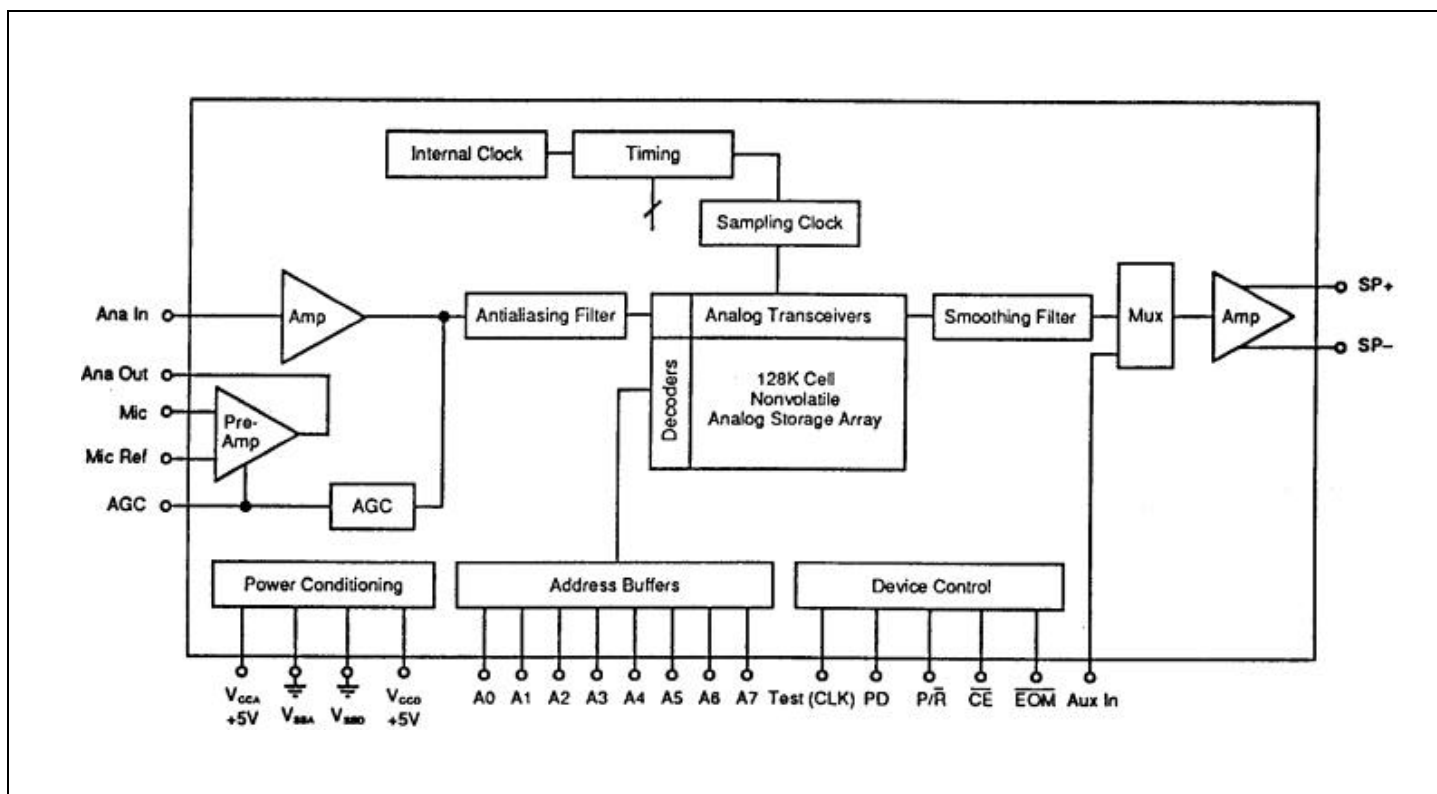

pull down the PD and CE lines, which are also used for playback, but does not allow Q1 to pull the P/R line down. The PD and CE lines must be low for record or playback, but the P/R line is held low only during record.

### **Q1 Playback Latch Circuit.**

Pull-up resistor R1 normally holds the PD and CE lines high. To playback a message, these lines are momentarily brought low by S1 or and-gate Q4. This starts the playback cycle.

During playback, a positive voltage appears on the SPKR +/- lines, which are differential outputs from the speaker amplifier. Actually, both lines have a positive voltage on them; the +/- signs refer to the phase of the output, not the dc polarity. The positive voltage on these lines turns on Q1 through R4 and R5 and holds Q1 on until the end of the message. Q1 thus latches the ground on the PD and CE lines.

At the end of the message, a short ground pulse appears at the pin 25 EOM line. This ground is applied to the base of Q1 through CR2, shunting the voltage from R4 and R5, and thereby turning off Q1. This stops the playback, resets the internal address pointer to zero, and powers down the U1 chip.

### **Q2 ID Key Circuit.**

The base of Q2 is biased on or off by current from R1 in the Q1 latch circuit. When that circuit is in a playback cycle, Q2 is turned on, which applies +5Vdc to the outside world. In repeater applications, this signal is applied to the COR board to hold the transmitter on while an ID message is played back. In other applications, such as a contest CQ caller, this voltage can be used in a similar fashion to key a transmitter.

### **Timer and ID Trip Circuits.**

Timer U3 puts out a logic high when it is running and a low when the time period expires. The timer starts running when the EOM ground

pulse is applied from the U1 chip at the end of a message. It normally runs for about 9 minutes, which is the time constant set by R15 and C16. The capacitor slowly charges, and when the voltage at pins 6 and 7 of the timer ic reaches a certain threshold, the timer snaps to a low output.

The timer output is applied to the emitter of and-gate Q4. The base of the and-gate is controlled by the voltage applied through R14. If a positive voltage is applied to the gate of Q4 while the emitter is held at ground by the output of the timer, the collector of Q4 applies a ground to the S1 circuit to start playback. If the timer is still running, the emitter of Q4 is high, so even if a voltage is applied at the base, Q4 cannot apply a ground to the S1 circuit to start playback.

### **Q3 One-Shot Stage.**

Q3 acts almost as a one-shot multivibrator, but not quite. Q3 normally is held off by bias through R13. The TRIP input at E2 is made to be driven by a COR board from a circuit which is high when the receiver squelch is open and low when closed. With our COR boards, this is driven from a circuit after the courtesy beep delay; so it is tripped just after the courtesy beep.

While the triggering circuit is high, C15 is discharged through CR3. When the triggering circuit goes low, C15 charges slowly through R13. While it is charging, C15 holds the voltage at the base of Q3 lower than the emitter voltage, causing the transistor to turn on and apply a positive voltage to the base of Q4.

In certain installations which can provide a positive pulse directly, the Q3 stage is not used. This is normally true when the COR-4 is used, because it has an internal one-shot stage which provides a nice square-wave positive pulse when the courtesy beep occurs.

### **Addressing.**

There are two types of addresses

used in the U1 chip. The first is an internal address pointer, which at any given time, keeps track of which memory cell is next to be read or written. At the beginning of a record or playback cycle, it starts at a starting location and cycles through until the end of the message and remains there until the PD line is brought high, which resets it to the starting address again.

The starting address normally is set by the address control lines on the upper left side of the pc board. As the board comes from the factory, these lines are all strapped to ground by pc board traces; so the starting address is zero. If one or more of these lines is raised to +5Vdc, the starting address for a given record or playback cycle is changed to some other location in memory. There is an extensive discussion of memory addresses earlier in this manual, under *OPERATION*, in a subsection titled *Addressing More Than One Message*.

### **Power Distribution.**

In the DVR-1, the +5Vdc operating voltage for the board is derived through three-terminal voltage regulator U2. Electrolytic capacitors on the input and output provide a low impedance to ground for audio and prevent oscillation in the voltage regulator amplifiers.

It is important to note that there are two separate +5Vdc busses on the board and separate sets of Vcc and Vss pins on the recorder ic for digital and analog power supplies. Because noise from the switching and clock circuits in the chip could affect the quality of the recording and playback audio, these two power paths are carefully separated and filtered from each other at various frequencies from audio up through the vhf range. This is also the reason a special microphone reference line is used to carefully establish the reference point used for the op-amp microphone preamp to suppress any noise from affecting the recording. It is important to maintain these features if you

make any modifications to the circuits.

## TROUBLESHOOTING.

### General.

Tracking down trouble is fairly straightforward. The *Theory of Operation* section describes the signal path and what each circuit does.

Remember that the ic's are static sensitive. You don't want to further damage the board while troubleshooting. A ground wrist strap should be worn when handling the ic's.

Significant logic voltages are high's (near +5V) and low's (near ground) as marked on the schematic by the little pulse symbols. Following is a stage-by-stage description of other voltages which should be present under various conditions.

A logical troubleshooting procedure would be to start by checking for expected operation with the manual playback and record switches, S1 and S2. If you can't hear any audio, then check various voltages and logic levels. An oscilloscope may be necessary to check audio levels. If the unit works manually but the timer and external trip circuits do not respond as expected, then trace those signals through the circuit, referring to the schematic diagram and information in the *Theory of Operation* section of the manual.

### Digital Recorder U1.

All analog circuits in 1020A ic U1 are referenced to an internally generated bias of approximately 1.5Vdc. This voltage can be measured at the mic input (pin 17), mic ref (pin 18), ana input (pin 20), and ana output (pin 21), but only in the record mode. In playback mode, these pins measure near ground. The speaker output pins (14 and 15) should each measure about 1.5 Vdc to ground in playback mode.

The agc line at U1 pin 19 rests at about 1.5Vdc in record and peaks up just a little bit if you apply loud audio to the microphone to make the agc take action.

Here are some typical ac voltage measurements. In record mode, the mic input voltage at pin 17 should be about 20 mVp-p. The analog input voltage at pin 20 should be about 50 mVp-p. In playback mode, the speaker output between pins 14 and 15 should be about 3Vp-p (1.5Vp-p ref ground).

Normally, the audio output is applied through audio output potentiometer R8 to an external audio circuit, but if you have a speaker connected, it must either be a 16Ω speaker or have a resistor in series to make the total load impedance 16Ω and the speaker must be connected between pins 14 and 15 of U1 and not to ground. The control signal pins on U1 are at logic levels noted on the schematic. The only one which isn't obvious is the EOM line at pin 25, which rests at 5Vdc and goes to ground temporarily under two conditions. In playback mode, the EOM line has a short ground pulse (about 15 mSec) at the end of each message. If the message runs to the end of the 20 second recording capacity, the EOM line goes low to indicate an overflow condition and stays low if the CE and PD lines are held low. This condition is reset when the PD line goes high.

### Timer U3 and Switching Transistors.

As indicated on the schematic diagram, the voltage at pins 6 and 7 of timer U3 charges slowly up to about 3.3Vdc, at which time, the timer output trips and pins 6 and 7 drop back to ground potential. When a reset pulse is applied to pin 2, the voltage at pins 6 and 7 starts to charge up again.

When the timer expires, output pin 3 drops to ground potential, and this is connected to the emitter of Q4. If a positive voltage is applied to the base of Q4 during this time, the ground from the timer is transferred to the start playback circuit on U1 (at S1).

The positive signal pulse which is applied to the base of Q4 can be gen-

erated by Q3. The external COR circuit, which is connected to trip input E2, should normally be high and go low to trip Q3. The leading edge of the high-low transition makes C15 and Q3 generate a positive pulse shaped about as shown on the schematic. When this pulse turns on Q4, the pulse is stretched somewhat as shown at the collector of Q4 on the schematic.

Q2 provides a positive voltage to the key output at E3 whenever a message is played back. The base of Q2 is turned on not by Q4, but by Q1 and R1, and remains on for the duration of the playback.

Q1 initially is turned on by a ground pulse from S1 or Q4. It is held on by voltage applied through R4 and R5 from the speaker output of U1, which has dc bias only during playback. At the end of the message, the EOM ground pulse from U1 pin 25 turns off Q1.

During record, pressing S2 grounds the output of Q1 through CR1 to cause U1 to run as it does in playback; however, S2 also grounds P/R pin 27, which puts U1 in record mode instead of playback.

### Power Supply Circuit.

The acceptable range of operating voltages is +8 to +14 Vdc. Current drain normally is about 30 mA at idle and 48 mA in playback mode. U2 regulates the input to provide +5Vdc. U2 will current limit at about 100 mA if its output is shorted to ground. In such a case, the case of U2 will be very warm, but no damage should occur. It is very important, though, to protect the entire board from voltage transients and reverse polarity, which will cause damage.

# PARTS LIST.

Ref Desig	Description	(marking)				
C1-C4	0.1µf monolithic	(104)	CR1-CR3	1N4148 switching diode	R13	680k
C5	.001µf	(102, 1nM, or 1nK)	MK1	electret microphone	R14	150k
C6	0.1µf monolithic	(104)	Q1	2N3904	R15	1 meg
C7	47µf electrolytic		Q2-Q3	2N3906	S1-S2	pushbutton switch, spst
C8-C10	0.1µf monolithic	(104)	Q4	2N3904	U1	ISD-1020A recorder
C11	1µf electrolytic		R1-R5	47k	U2	78L05 5V regulator
C12	4.7µf electrolytic		R6	2.2k	U3	NE-555 timer
C13	47µf electrolytic		R7	15k	Z1	ferrite bead, prestrung
C14	1µf electrolytic		R8	22k or 20k pot		
C15	0.1µf monolithic	(104)	R9	47k		
C16	470µf electrolytic		R10	510k		
C17	.01µf ceramic	(103)	R11	150k		
			R12	4.7k		

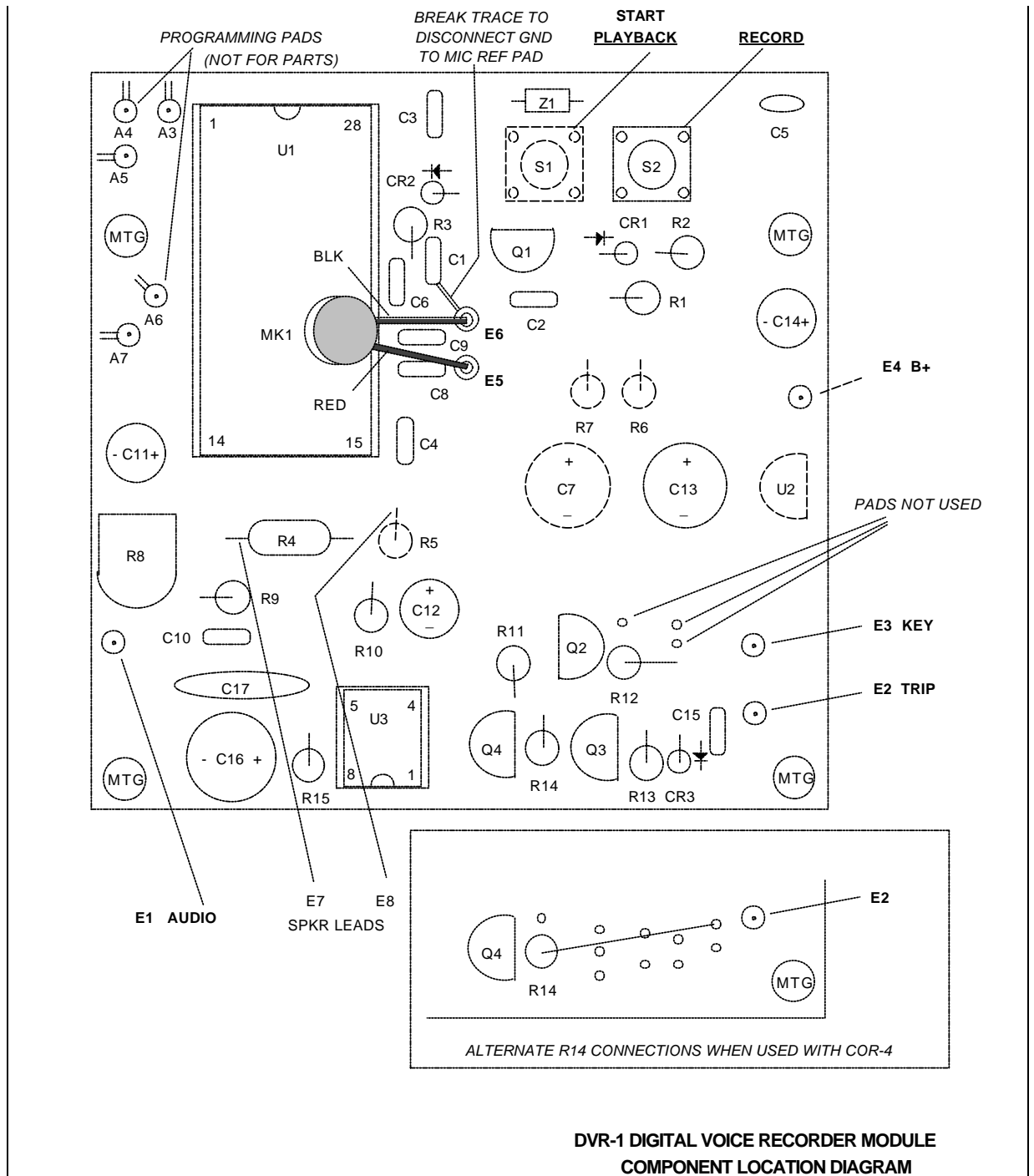

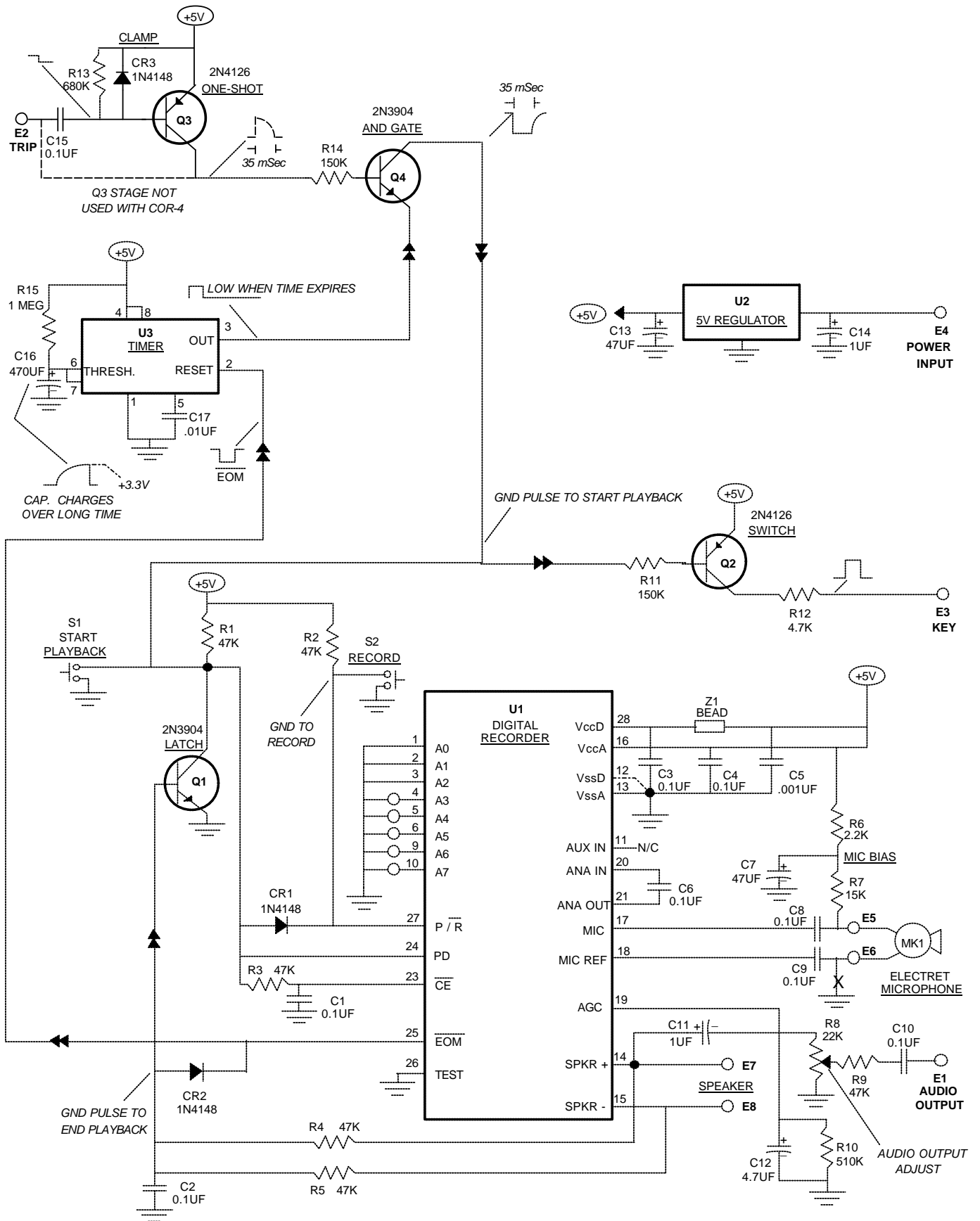

**DVR-1 DIGITAL VOICE RECORDER MODULE**