

HAMTRONICS® DVR-3 DIGITAL VOICE RECORDER ASSEMBLY, INSTALLATION, AND OPERATION

TABLE OF CONTENTS

GENERAL INFORMATION.....	1
Functional Description.....	1
Enhancements.....	1
Recording Quality.....	1
ASSEMBLY.....	2
Construction Methods.....	2
Precautions.....	2
Assembly Procedure.....	2
INSTALLATION.....	2
Mounting.....	2
Wiring.....	3
OPERATION.....	3
General.....	3
Recording a Message.....	3
Voice ID Operation.....	4
Message Playback for Testing.....	4
Playback by DTMF Request.....	4
ENHANCEMENTS.....	4
General.....	4
Changing Tone.....	4
Addressing More Than One Message.....	4
Multiple Messages.....	5
Remote Control of Multiple Messages.....	5
THEORY OF OPERATION.....	5
General.....	5
Recording Technology.....	6
Audio Recording Circuits.....	6
Audio Playback Circuits.....	6
U1 Control Circuits.....	6
S2 Record Switch Circuit.....	6
Q1 Playback Latch Circuit.....	6
Remote Control Circuits.....	7
Q2/Q3 ID Key Circuit.....	7
Addressing.....	7
Power Distribution.....	7
TROUBLESHOOTING.....	7
General.....	7
Digital Recorder U1.....	7
Switching Transistors.....	7
Power Supply Circuit.....	8
PARTS LIST.....	9
COMPONENT LOCATION DIAGRAM.....	9
SCHEMATIC DIAGRAM.....	10

GENERAL INFORMATION.

Functional Description.

The DVR-3 is a versatile pc board module, which is designed primarily as a voice id'er and message recorder for the REP-200T Repeater. It is a special version of the general

purpose DVR-1 module. The difference is that the DVR-3 substitutes direct control interfaces with the COR-5 Control Board for the general purpose timer and logic circuits on the DVR-1, and the DVR-3 uses audio off the air for recording instead of a microphone.

The DVR-3 module is based on the ISD-1020A chip, using direct analog eeprom technology. The recording is good speech quality, equivalent to what you would expect using a cassette tape recorder. The solid-state recording lasts ten years or more and requires no battery backup.

Use of the DVR-3 requires firmware version 2.06 or later in the REP-200 Repeater. This includes all repeaters manufactured after December 1993. Older repeaters can be retrofitted by replacing the eeprom; no hardware changes to the control board are required.

The COR-5 Controller provides the means to enable either the voice id or conventional cw id, and it provides the triggering signal for the DVR-3 module and the necessary timing to ensure that the id occurs at the proper time and that the transmitter is keyed each time that the id message is played back. It also allows the message to be recorded and played back through dtmf commands.

Enhancements.

The 20 seconds of recording time normally is accessed all as one unit. However, with the addition of some external addressing switches, the 20 second capacity can be broken up, any way you like, into multiple messages. Although, switching circuitry to do this is not provided, the address line connections are provided, and information on how to add switches to do your own enhancements is given later in the manual.

Other enhancements may be added to suit your application. With a few changes, you can make the message repeat periodically or loop continuously.

Recording Quality.

The ISD-1020A is an amazing new ic which implements an entire digital voice recording and playback system in one chip. This brings real voice to the radio community at a previously unheard-of low price.

However, we don't want you to expect a one-chip system to sound like a music CD.

Limitations imposed by the restraints of putting everything on one chip result in good communications quality sound, but not hi-fi. There is a little noticeable hiss and a little distortion because of the digitizing and the limited sampling rate imposed by the number of eeprom cells which will fit on a chip. It is definitely real voice, though, and not a synthesized, artificial-sounding voice.

If you want to enjoy the benefits of digital recording technology at an attractive price and are willing to live with less than perfect audio, you will be pleased. We tell you this now because expectations have a lot to do with satisfaction.

ASSEMBLY.

Construction Methods.

Assembly is relatively straight forward. Use the parts list and component location drawing as guides. The schematic diagram is provided for reference, but it is not needed for construction.

During assembly, orient the board right side up as shown in the component location diagram. The top is the side with the terminal numbers.

The four labeled holes around the perimeter of the board are for wires connecting to the COR-5 Control Board. Note that the board originally was designed for the DVR-1, and some pads are not used in the DVR-3, and some are used in different ways. Be sure to look at the diagram carefully to avoid installing parts in the wrong holes.

The five pads at the upper left are for optional address line connections, which are only used if you choose later to enhance operation with multiple messages. For now, disregard these holes; there are no components to install in them.

Precautions.

Note that the ic is static sensitive because it uses cmos technology. The warranty does not cover static damage; so handle it with care. Leave it in its protective carrier until assembly

is done; and then plug it in, using suitable static handling precautions. A grounded wrist strap should be worn whenever cmos parts are handled. Even after assembly, it is possible to damage cmos parts if static builds up from walking or sliding a chair on a carpet, etc. Always use precautions when handling a board with cmos parts.

Be careful not to confuse parts marked similarly, such as 150K and 510K resistors. Double check each part as installed. When done, if parts are short and others are left over, go back and check each part to be sure a wrong value didn't get installed somewhere.

The pc board uses plated-through holes; so only the bottom of the board needs to be soldered. Because it is more difficult to remove parts from plated-through holes, be sure parts are correct before soldering. Traces are close together; so use a fine tip on the soldering iron. All parts should be installed flush with the board.

Assembly Procedure.

Install and solder the parts in each of the following steps as you proceed.

a. Refer to the view of the DVR-3 board installed next to the COR-5 board on page 3. Before attaching any parts to the board, lay it in the repeater chassis with the two boards aligned as shown and about 1/8 inch between the boards. Hold the board in place, and carefully mark the positions of the four mounting holes. Remove the board, center punch the exact hole positions, and drill four 1/8 inch holes. Then, set the chassis aside and proceed with assembly of the DVR-3 board.

b. In each of the four mounting holes in the board, install a hex standoff with a 4-40 x 1/4 inch screw. Make sure the screw is on the top side of the board, which has lettering on it.

c. Install the ic socket on the board, positioning the end with the notch toward the top.

d. Install the two pushbutton switches. Note that they fit properly

Wire Color	Length	Terminal
Blue	8 in	E3 KEY
Brown	12 in	Pad by R11
Gray	12 in	E1 AUDIO
Green	15 in	Top of R6
Yellow	7 in	E2 TRIP
Violet	3½ in	Between 2 Pads As Shown

only with the leads oriented toward the left and right, not up and down.

e. Install potentiometer R8.
 f. Install ferrite bead Z1.
 g. Install the five transistors, observing proper orientation. On Q5, be careful to form the leads as shown and get them in the proper holes. (This hole pattern originally was for an ic on the DVR-1.)

h. Install all capacitors, observing polarity on electrolytics.

i. Install all resistors. On vertically-mounted parts, the body of the part is indicated by a circle on the diagram. R6 will have wires connected to the top lead later. For now, simply cut the top lead, leaving 1/8 inch as a terminal. R7 is installed horizontally, with leads inserted in the two pads farthest apart in a 4-pad pattern. The inner two pads are not used.

j. Install diode CR2, observing polarity. The banded (cathode) end must be oriented as shown (at bottom of diode and with diode in the hole shown).

k. Solder one end of a short bus wire (lead clipping) to the B+ input pad, which is the lower pad of the cluster of 3 as shown. (The larger pad marked "B+" on the board is not used in this model because +5Vdc is supplied to the DVR-3 directly from the COR-5 Control Board.) The bus wire should be about 5/8 inch long.

l. Cut and strip 3/16 inch of insulation from one end of the hookup wires listed in Table 1, and solder that end of each to terminals on the board. Refer to component location diagram. The violet wire is a jumper between two pads on the board. Dress it as shown, which is deliberately far from the ic and the audio input circuit of R6.

m. Strip the free end of each of the five long wires 5/16 inch. Dress them as shown in the diagram, and then loosely twist them together for

about five inches, starting at the lower right-hand corner of the board.

n. Using suitable static protection described earlier, carefully unpack the ISD-1020A ic and install it in the socket. Be sure to orient it with notch as shown. Be careful that all the pins actually go into the socket. It is easy for some to bend underneath or extend over the outside of the socket. Do not bend any of the pins excessively, as they may break from repeated stress.

o. This completes assembly. Check over construction to be sure all parts are installed in proper places, with proper polarities, and check solder connections for any cold solder joints, solder splashes, etc. Check that the indicated holes are empty and that components were not accidentally installed in the wrong holes. If any parts are missing, check to be sure that other parts are not left over; since a part may have been installed in the wrong place. There should be four screws left over.

INSTALLATION.

Mounting.

Four mounting holes should have been drilled in the repeater chassis before assembling the DVR-3 pc board. Now, set the board in place as shown below, and secure with

four 4-40 x ¼ inch screws.

Caution: The digital recorder ic is static sensitive. Use suitable handling precautions, including grounding yourself, to avoid damage.

Wiring.

Dress the wire leads away from the DVR-3 board, as shown in the diagram below, along the front edge of the COR-5 board, and under the LED leads. Dress individual lead ends and solder as follows.

a. Connect the gray "audio output" wire to the loop at the top of R8 on the COR-5 board. Check that the resistor is oriented as shown, because the loop at the top of the resistor would be connected to the wrong point if the resistor was inadvertently reversed when the COR-5 board was assembled. Wrap the wire around the resistor lead, and tack solder.

b. Connect the brown "playback control" wire to the Voice ID Trip output pad at the right-front corner of the COR-5 board. (This is the pad which used to be called "Aux. #2" before the DVR-3 was available.) Insert the stripped end of the lead into the hole just enough to hold it, and solder from the top of the board.

c. Connect the blue "key carrier" wire to the top lead of R34, as shown in the diagram. Check that the resistor is oriented as shown, because the loop at the top of the

resistor would be connected to the wrong point if the resistor was inadvertently reversed when the COR-5 board was assembled. Wrap the wire around the resistor lead, and tack solder.

d. Connect the yellow "record control" wire to the top lead of R38, as shown in the diagram. Check that the resistor is oriented as shown, because the loop at the top of the resistor would be connected to the wrong point if the resistor was inadvertently reversed when the COR-5 board was assembled. Wrap the wire around the resistor lead, and tack solder.

e. Connect the green "rcvr audio" wire to the third feedthrough capacitor from the front along the receiver compartment shield. This feedthrough has an existing gray wire connected to the audio input of the COR-5 board. Leave the original wire and add the new green wire.

f. The DVR-3 board gets its +5Vdc power directly from the 5V trace on the top of the COR-5 board. Bring the bus wire lead previous installed on the DVR-3 board from the +5V input pad on that board across to lay on top of the +5V bus trace on the COR-5 board as shown, and trim the length. Tack solder to the foil. Check to be sure that there is no short circuit to any other foil traces.

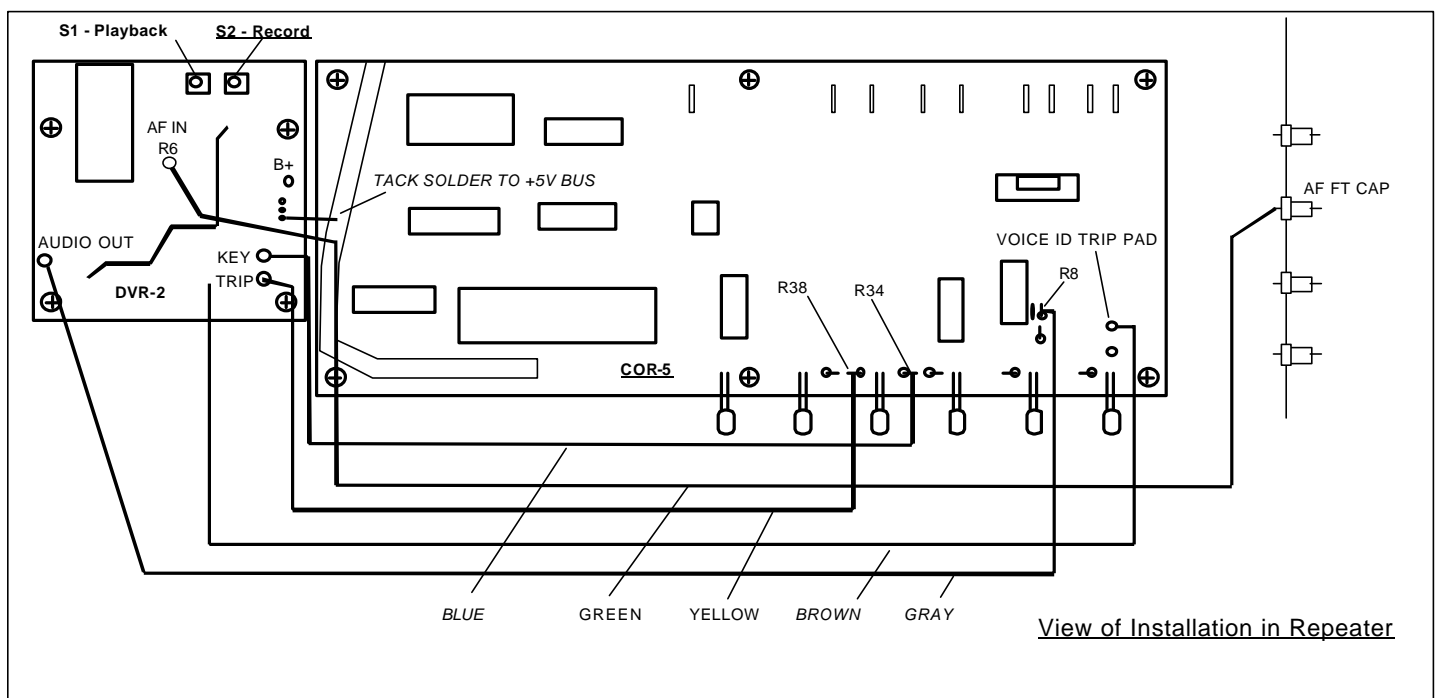

OPERATION.

General.

Use of the DVR-3 requires firmware version 2.06 or later in the REP-200 Repeater. This includes all repeaters manufactured after December 1993. Older repeaters can be retrofitted by replacing the eeprom; no hardware changes to the control board are required.

Recording a Message.

There are two ways to record. In either method, the audio for the recording is taken from the receiver; so the microphone on a mobile radio or handie talkie is used to make the recording.

In the first method, key the microphone and depress RECORD switch S2 and PLAYBACK switch S1, simultaneously, on the DVR-3 board while speaking. This method normally is used only for testing.

In the second, and much easier method, especially for remote recording or recording without removing the cover from the repeater, you use the microprocessor in the control board to "press the record button" for you. To do this, send the dtmf command for the Record Voice Msg function, which usually is "099*". Allow time for the command to be acknowledged. Then, key the microphone and say the message. Allow about a second of silence after the message, and then unkey your microphone. It is that simple.

You can either unkey the mic as soon as you send the command, in order to hear the 'R' acknowledgment, and then rekey the mic to make the recording; or you can simply keep the mic keyed and allow enough time for the controller to recognize and carry out your command. The former method is preferred, because it allows you to know for sure that the command was received and allows you to know precisely when the recording begins — when you rekey.

Be sure to allow a second or two after pressing ptt switch before speaking, and allow about 1 second after the end of your message before releasing the switch. This will allow for smooth transition between carrier turn on and playback of the

actual message. Total recording time is 20 seconds.

When you send the Record Voice Msg command, the yellow TimeOut led will illuminate to indicate the DVR-3 is ready to record. This led is used for convenience; it does not mean the time out timer had been triggered.

Voice ID Operation.

To allow automatic voice id to occur, the Voice ID option must be enabled on the COR-5 control board, either by sending the appropriate dtmf command (usually "302*") or by having that option default on by eeprom programming.

Message Playback for Testing.

To playback for testing, momentarily depress PLAYBACK switch S1. Repeater is keyed automatically while message is running. Note that the voice id might be activated when the repeater is first turned on. Although unintentional, this is the way the logic circuits on the DVR-3 board respond at power up, and it does not indicate a problem.

Audio level pot R8 should be adjusted for desired deviation level on the transmitter. This adjustment should be made only after all other audio adjustments on the exciter

and COR-5 board have been made. You should set the voice id level for ± 5 kHz deviation on the loudest part of the recording.

Playback by DTMF Request.

Any repeater user can request message playback by sending the Playback Voice Msg command, usually "003*". You can use the command for testing, as well. You can make prerecorded messages available for call up by club members, for instance.

ENHANCEMENTS.

General.

This section of the manual provides information on some modifications which can be done to allow the DVR-3 to be used in some other applications. Some of these are rather involved and require a good background in digital electronics to accomplish. We recommend that you only tackle them if you feel your background is sufficient, and even then, you should operate the unit in its standard setup as designed before attempting any modifications so it will be easier to solve problems which may occur.

The Theory Of Operation section gives some additional explanation of the operation of the recorder ic,

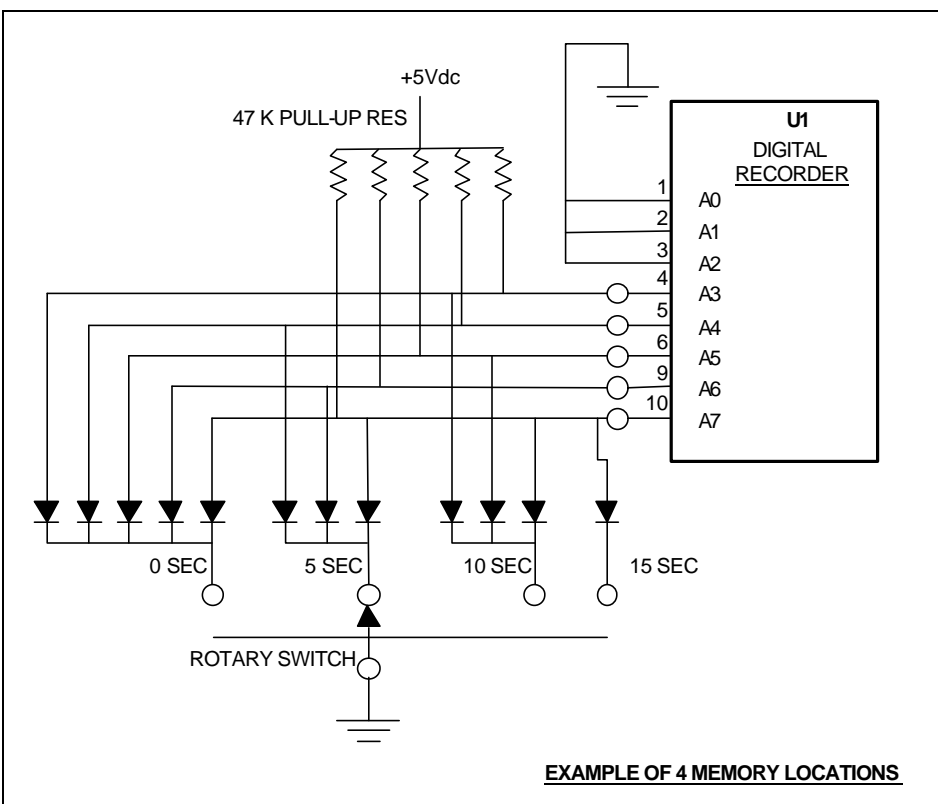

Table 2. Address Line Binary Weighting.

Address Pads	A7	A6	A5	A4	A3
Weight (sec.)	16	8	4	2	1

which may allow you to do some other adaptations. If you develop an application you want to share with others, we invite you to let us know. If we can, we'll add it to the manual to make it available to future DVR-3 users.

Changing Tone.

The bass response of the recording circuit is controlled largely by the values of C8 and C9. You can increase the values of these capacitors to get more low frequency response or decrease them for less low frequency pickup. Both capacitors must be the same value. If you want to increase the value, it may be necessary to change to a different type of capacitor, such as polyester (mylar) capacitors, in order to get a large value.

Addressing More Than One Message.

The rest of the enhanced operation techniques all depend on the user having a good grasp of binary addressing. You should not attempt any of these modes unless you feel comfortable with the discussion that follows.

The ISD1020A ic can be operated in many different modes. The simplest is the "addressed" mode, in which the various 8-bit address lines marked "A0" through "A7" on the schematic diagram are used to set binary addresses for the starting points of various message storage areas in the chip.

The 1020 ic can be looked at as a miniature tape recorder with 20 seconds worth of tape. It has the ability to pre-position the playback/record head anywhere on this 20 second tape before we begin operation. The device has 160 valid addresses giving an address resolution of 0.125 seconds. This means 8 address counts equal 1 second of record time.

To determine what address to give the device, we must first convert seconds into binary counts. A 1-second resolution is adequate for our purposes. Since 8 counts equal one second and 8 is an even binary

multiple, we can ignore all the counts less than eight. We do this by strapping A0, A1, and A2 to ground and just programming the 5 remaining bits. Using switches and diodes (for isolation), we can select any interval between 1 and 19 seconds for the start of record or playback.

To program addresses, we need to tie individual address lines to ground (logic 0) or +5Vdc (logic 1). Table 2 gives the binary address weight of each address line pad on the pc board.

Using normal binary numbering to do the addressing, following are examples to illustrate how to program at one second intervals. Not all addresses are given, only enough to give you the idea of how binary digits are added to yield the desired address.

Note that the address is the starting address of either record or playback message and must be set before the RECORD or PLAYBACK switch is pressed. Because we are addressing in one-second increments, the highest practical address is 19 seconds.

We mentioned earlier that there are other operational modes besides the addressing mode. These are enabled by tying both A6 and A7 high at the same time, which tells the ic that instead of using message starting addresses, we want the chip to operate in a special mode. These other modes are selected by pulling one of the A3-A5 lines high while the A6 and A7 lines are also high. For instance, tying lines A3, A6, and A7 high selects a special message looping mode, which was discussed earlier. There are other modes which we won't discuss because they are used for testing or in modes not suitable for our type of product. All these operational modes use a message space starting address of zero; the programming in these cases establishes a mode of operation and not the starting address of the message.

Multiple Messages.

Using addresses, you can record and playback multiple messages, depending on the starting addresses being properly set before record or

Table 3. Address Examples.

Start Address	Address Pads				
Location (sec)	A 7	A 6	A 5	A 4	A 3
0	0	0	0	0	0
1	0	0	0	0	1
2	0	0	0	1	0
3	0	0	0	1	1
4	0	0	1	0	0
5	0	0	1	0	1
6	0	0	1	1	0
7	0	0	1	1	1
8	0	1	0	0	0
15	0	1	1	1	1
16	1	0	0	0	0
17	1	0	0	0	1

playback is initiated. When a message is recorded, the recording starts and runs until you release the RECORD switch. At the end of the message, the ic embeds an "EOM" (end of message) marker, which controls where the playback will automatically stop.

Keep in mind when recording a new message that if you record a message longer than the address space you have reserved for it, you will begin erasing the next message in the series (or run over the end of the 20 second capacity of the chip). If you then try to select the message you just erased part of, you will get the end of the new message starting at the message address of the message you just corrupted. *Whenever you play a message, the ic starts at the selected address, whether or not that coincides with the start of a message, and it runs until it sees an EOM marker.* If you want to record a message longer than its allowed message space, just go ahead and do it; but remember that the next message just isn't available any more.

The schematic diagram below shows how multiple message addressing is implemented in a simple system with four 5-second message spaces starting at 0, 5, 10, and 15 seconds into the recording space. You can easily set up any number of spaces at whatever addresses you want; these are just used as an example. The spaces don't need to be evenly divided as in the case.

The five resistors are used to pull up the address lines to +5Vdc when they are not grounded through the diodes. For simplicity, we depict a rotary switch in a straight line format. Note that any

type of switch can be used. The only thing that matters is which lines are grounded *at the start* of a record or playback cycle. It doesn't even matter if you change an address setting in the middle of a cycle; that would be ignored. You can devise any sort of switching scheme you like as long as you set the starting address as defined earlier.

Remember that the diodes are installed for those address lines that are to be programmed lo (ground), not hi (+5Vdc). The pull-up resistors provide the logic hi voltage for those address lines which are not grounded through diodes.

Remote Control of Multiple Messages.

If you want to be able to control which of several messages is used, and do it by remote control, you can use a unit, such as our TD-2 DTMF Decoder/Controller to select a particular group of diodes, as shown in the schematic for multiple message addressing. Just make sure that you don't turn on remote control latches for more than one address at once or the address will be mixed up.

THEORY OF OPERATION.

General.

Following is a thorough discussion of the operation, first of the digital voice recorder ic, and then of the support circuitry. You will need a background in digital electronics to understand some of it, although it isn't too complicated.

Recording Technology.

The ISD-1020A ic is an analog sampled data system, with on-chip microphone preamp, agc, anti-aliasing and smoothing filters, storage array, speaker driver, control interface, and internal precision reference clock. This system uses eeprom technology to directly record analog signals so no d-a and a-d converters are required.

The 1020A ic uses a sampling rate of 6.4 kHz for 20 seconds of storage time, and it has an anti-aliasing filter which cuts off at 2700 Hz. If the frequency response was higher, the recording time would be less, because at least two samples per cycle are required to reproduce any frequency.

Audio Recording Circuits.

Refer to schematic diagram at the rear of the manual and the block dia-

gram of the ic below. The DVR-3 records audio from the receiver audio signal taken from the feedthrough capacitor which feeds the audio to the COR-5 board for repeater audio. R6 and R7 is a voltage divider to provide the proper level to recorder ic U1 at pin 17. Pin 18 of the ic provides a reference input to the input op-amp. This is connected to the ground plane of the board to cancel any hum or noise pickup. The analog preamp output at pin 21 is coupled through blocking capacitor C6, which also serves to tailor the frequency response and level to match the repeater audio input.

During recording, the 1020A chip performs several stages of signal conditioning before the actual storage operation takes place. The first stage is the amplification of the input signal to a level optimized for the dynamic range of the storage circuits. This is done by the preamplifier, amplifier, and agc circuits in the chip. Amplification is done in two steps — initially by the input preamplifier and then by a fixed gain amplifier. The signal path between the preamplifier and the fixed gain amplifier is completed by a blocking capacitor, which allows the fixed amplifier to be connected to a line input instead in some applica-

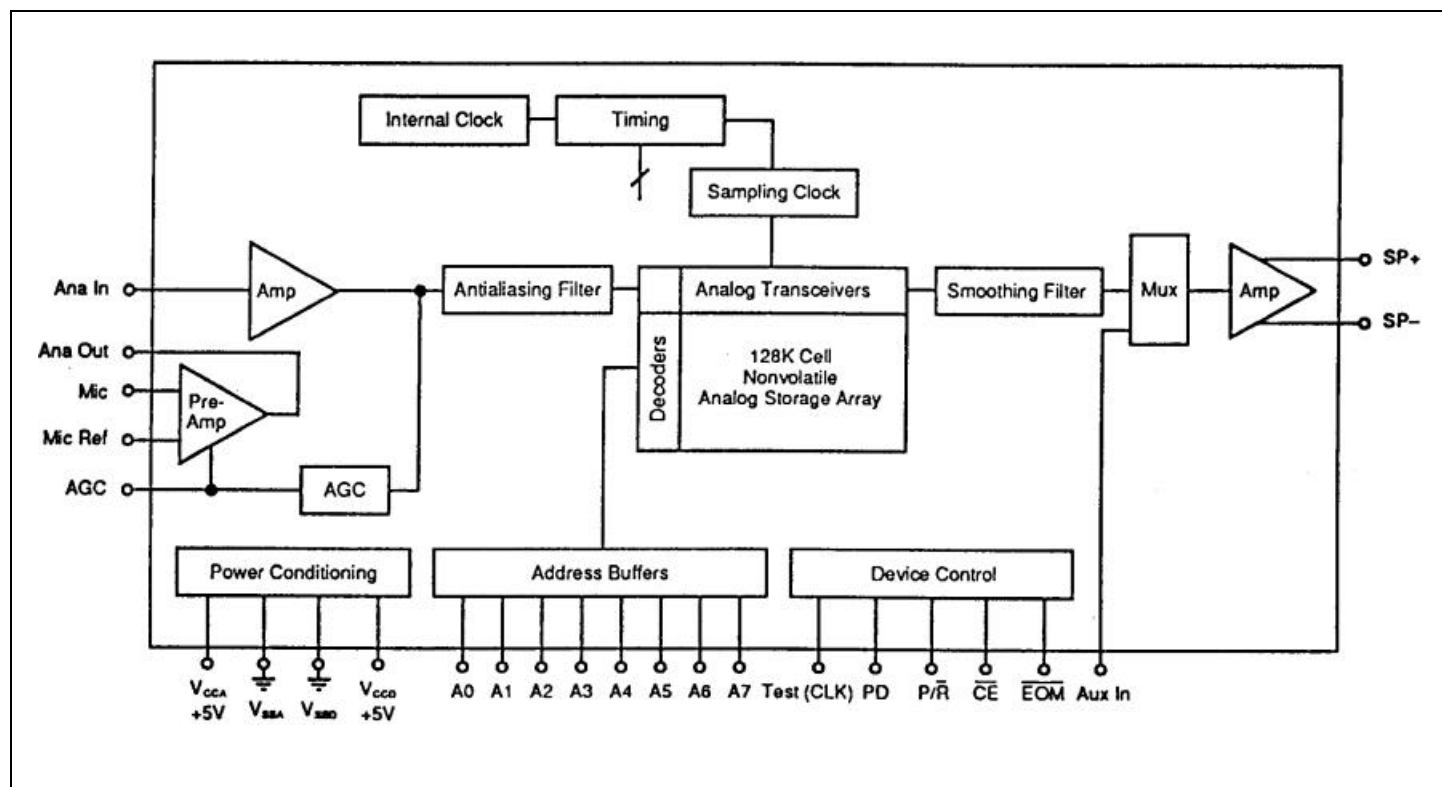

tions.

The preamplifier has automatic gain control, with the attack/release time constants set by R10/C12. The 20 dB or so of gain compression range on the preamp compensates for variations in voice characteristics and levels of speech volume.

The next stage of signal conditioning is done by the input filter. Although analog storage of the instantaneous voice level does not require an a-d converter, digital sampling is done in the time domain; so an anti-aliasing filter is required to limit any speech components to frequencies less than one-half the sampling rate. This is a primary requirement of any digital audio processing technology.

The processed waveform is then passed into the analog transceivers to be written into the analog storage array. Because the storage process takes longer than the sampling period, several samples are written at one time, and then another group of samples is written, and so on. The eeprom cells work similar to digital eeproms you are familiar with, but these eeprom cells actually store an analog voltage and not a digital signal (0's and 1's). The recording is non-volatile; it has a useful life of at least ten years even if no power is applied during part or all of that time.

Audio Playback Circuits.

During playback, the recorded analog voltages are sequentially read from the storage array, thereby reconstructing the sampled waveform. The smoothing filter on the output path removes the sampling frequency component and the original waveform is restored. The output of the smoothing filter is connected through an analog multiplexer into the output power amplifier.

Although not normally used in the DVR-3, two output pins (14 & 15) can provide direct speaker drive capability of about 50 mW rms (100 mW peak) into a 16Ω speaker — enough to be clearly heard from the other side of a normal sized room. An external audio signal can also be

applied to the speaker driver through the AUX IN at pin 11.

Audio for the repeater is derived from one line of the speaker driver. This audio is coupled through potentiometer R8, which allows for level adjustment, and R9/C10, which provides the proper output impedance and dc blocking.

U1 Control Circuits.

There are four control lines used on the ic, plus a test line which we do not use.

The PD (power down) line at pin 24, which is normally held low during record or playback, does two things when raised high. First, it resets the internal address pointer to zero. Second, it puts the ic in a power down state in which it draws very little current (for idling).

The P/R line puts the chip in a playback mode when high and record mode when low.

The CE (chip enable) line is what actually starts each record or playback cycle. It is held low to make the chip run.

The EOM line puts out a low signal under two conditions. First, when the playback mode reaches the end of a recording on the chip, the EOM line puts out a ground pulse of about 25 mSec length. Second, if the chip runs until the very end of its 20 second recording time, the EOM line goes low and stays low until the chip receives a PD signal to reset it.

S2 Record Switch Circuit.

Now that you know the functions of the control pins on the U1 chip, we can discuss how the external control circuits operate. *Refer to the schematic diagram.*

In order to record a message, S2 (or an external switch performing the same function) is depressed. The switch works in conjunction with pull-up resistor R2 to apply either +5Vdc or ground to playback/record pin 27 on the U1 chip. If S2 is not depressed, R2 pulls the P/R line high and the ic is held in the playback mode. When recording is necessary, S2 is depressed, and pin 27 is held low, in the record mode.

In order for the ic to "run", i.e., for the clock circuits to step through a message, S1 (or an external switch performing the same function) is depressed. This switch works in conjunction with pull-up resistor R1 to apply either +5Vdc or ground to power down pin 24 and chip enable pin 23 on the U1 chip. With S1 depressed, ground is applied to these pins, which causes the ic to either playback or record, depending on whether S2 is also depressed. With S1 released, the record or playback action stops, and the high on power down pin 24 makes the ic reset all its circuits for the start of a new cycle, in particular, this is what sets the address back to the starting address.

At the end of the recorded message, releasing the two switches stops the record cycle and causes the chip's internal control circuitry to put an "end of message" marker at the point in memory where the message ends. On playback, this marker controls where playback stops.

Q1 Playback Latch Circuit.

Pull-up resistor R1 normally holds the PD and CE lines high. To playback a message, these lines are momentarily brought low, either by S1 or by the playback control (voice id trip) output of the COR-5 control board, which is the brown wire. This starts the playback cycle.

During playback, a positive voltage appears on the AF OUTPUT +/- lines, which are differential outputs from pins 14 & 15 of U1. Actually, both lines have a positive voltage on them; the +/- signs refer to the phase of the output, not the dc polarity. The positive voltage on these lines turns on Q1 through R4 and R5 and holds Q1 on. Q1 thus latches the ground on the PD and CE lines.

At the end of the message, a short ground pulse appears at the pin 25 EOM (end of message) line. This ground is applied to the base of Q1 through CR2, shunting the voltage from R4 and R5, and thereby turning off Q1. This stops the playback, resets the internal address pointer to zero, and powers down the U1 chip.

Remote Control Circuits.

In order for the COR-5 Control Board to control the record and playback cycles of the DVR-3, two control lines are connected to the COR board. These simulate the actions of the manual switches, S1 and S2.

Playback control is connected through the brown wire to a dedicated port on the microcontroller chip on the COR-5. When the controller decides playback is required, it applies a ground pulse of approximately 100 milliseconds duration to the Playback Control input on the DVR-3. This starts the playback cycle, which continues due to the latching action of Q1, R4, and R5, as previously described. At the end of the message, U1 EOM pin 25 unlatches Q1.

To record, the controller board grounds the Playback Control line continuously while also grounding the Record Control line coming into Q4. Switches Q4 and Q5 have the same effect as pressing RECORD switch S2, i.e., putting U1 in the record mode.

The Record Control line is connected to the circuit on the COR-5 board which operates the Time Out led. Since no more microprocessor ports were available, the port which operates the led also is used for Record Control.

Q2/Q3 ID Key Circuit.

The base of Q2 is biased on or off by current from R1 in the Q1 latch circuit. When that circuit is in a playback cycle, Q2 is turned on, which applies bias to turn on Q3. That transistor, in turn, applies a ground to the exciter keying circuit on the COR-5 board. This action holds the transmitter on while an ID message is played back and operates independently from the microcontroller on the COR-5 board which normally keys the transmitter.

Addressing.

There are two types of addresses used in the U1 chip. The first is an internal address pointer, which at any given time, keeps track of which memory cell is next to be read or written. At the beginning of a record or playback cycle, it starts at a

starting location and cycles through until the end of the message and remains there until the PD line is brought high, which resets it to the starting address again.

The starting address normally is set by the address control lines on the upper left side of the pc board. As the board comes from the factory, these lines are all strapped to ground by pc board traces; so the starting address is zero. If one or more of these lines is raised to +5Vdc, the starting address for a given record or playback cycle is changed to some other location in memory. There is an extensive discussion of memory addresses earlier in this manual, under *OPERATION*, in a subsection titled *Addressing More Than One Message*.

Power Distribution.

In the DVR-3, the +5Vdc operating voltage for the board is derived from the regulated +5Vdc power bus on the COR-5 board. Electrolytic capacitor C13 provides a low ac impedance for the 5V bus on the DVR-3 board.

There are two separate +5Vdc busses on the DVR-3 board and separate sets of Vcc and Vss pins on the recorder ic for digital and analog power supplies. Because noise from the switching and clock circuits in the chip could affect the quality of the recording and playback audio, these two power paths are carefully separated and filtered from each other at various frequencies from audio up through the vhf range. This is also the reason a special microphone reference line is used to carefully establish the reference point used for the op-amp microphone preamp to suppress any noise from affecting the recording. It is important to maintain these features if you make any modifications to the circuits.

TROUBLESHOOTING.

General.

Tracking down trouble is fairly straightforward. The *Theory of Operation* section describes the signal path and what each circuit does.

Remember that the ic's are static sensitive. You don't want to

further damage the board while troubleshooting. A ground wrist strap should be worn when handling the ic's.

Significant logic voltages are high's (near +5V) and low's (near ground) as marked on the schematic by the little pulse symbols. Following is a stage-by-stage description of other voltages which should be present under various conditions.

A logical troubleshooting procedure would be to start by checking for expected operation with the manual playback and record switches, S1 and S2. If you can't hear any audio or the transmitter does not key when S1 is pressed momentarily, then check various voltages and logic levels. An oscilloscope may be necessary to check audio levels. If the unit works manually but the timer and external trip circuits do not respond as expected, then trace those signals through the circuit, referring to the schematic diagram and information in the *Theory of Operation* section of the manual.

Digital Recorder U1.

All analog circuits in 1020A ic U1 are referenced to an internally generated bias of approximately 1.5Vdc. This voltage can be measured at the mic input (pin 17), mic ref (pin 18), ana input (pin 20), and ana output (pin 21), but only in the record mode. In playback mode, these pins measure near ground. The audio output pins (14 and 15) should each measure about 1.5 Vdc to ground in playback mode.

The agc line at U1 pin 19 rests at about 1.5Vdc in record and peaks up just a little bit if you apply loud audio to the audio input to make the agc take action.

Here are some typical ac voltage measurements. In record mode, the mic input voltage at pin 17 should be about 20 mVp-p. The analog input voltage at pin 20 should be about 50 mVp-p. In playback mode, the audio output between pins 14 and 15 should be about 3Vp-p (1.5Vp-p ref ground).

The control signal pins on U1 are at logic levels noted on the schematic. The only one which isn't obvious is the EOM line at pin 25,

which rests at 5Vdc and goes to ground temporarily under two conditions. In playback mode, the EOM line has a short ground pulse (about 15 mSec) at the end of each message. If the message runs to the end of the 20 second recording capacity, the EOM line goes low to indicate an overflow condition and stays low if the CE and PD lines are held low. This condition is reset when the PD line goes high.

Switching Transistors.

Q3 provides a ground to the key output at E3 whenever a message is played back. The base of Q2 is turned on by Q1 and R1, and remains on for the duration of the playback. Q2, in turn, biases Q3 on.

Q1 initially is turned on by a ground pulse from S1 or the Playback Control line. It is held on by voltage applied through R4 and R5 from the audio output of U1, which has dc bias only during playback. At the end of the message, the EOM ground pulse from U1 pin 25 turns off Q1.

During record, pressing S2 grounds the P/R pin 27, which puts U1 in record mode instead of playback. S1 must also be pressed at the same time or the Playback Con-

trol line must hold the S1 circuit at ground to make the ic run during record. Because there is no output on the audio output pins (14 & 15) during record, Q1 does not latch on as it does in playback mode.

Switching transistors Q4 and Q5 act as a buffer for the Record Control input from the Time Out led circuit on the COR-5 board. When the COR-5 requests a record session, Q5 grounds the S2 record circuit as if S2 was pressed.

Power Supply Circuit.

The acceptable range of operating voltages is +4.75 to +5.25 Vdc. Current drain normally is about 4 mA at idle and 22 mA in playback mode.

It is very important, though, to protect the entire board from voltage transients and reverse polarity, which will cause damage. If the DVR-3 is powered from the COR-5, as is normal, then you don't need to worry about transients. But if you use a separate power source, be careful, especially if any relays are powered from the same line. Any relay coils or other inductive devices must have diodes connected across them to absorb transients generated

when current to the coil is switched off.

PARTS LIST.

Ref Desig	Description	(marking)
C1-C4	0.1µf monolithic	(104)
C5	.001µf	(102, 1nM, or 1nK)
C6	0.1µf monolithic	(104)
C7	not assigned	
C8-C10	0.1µf monolithic	(104)
C11	1µf electrolytic	
C12	4.7µf electrolytic	
C13	47µf electrolytic	
CR1	not assigned	
CR2	1N4148 switching diode	
Q1	2N3904	
Q2	2N3906	
Q3	2N3904	
Q4	2N3906	
Q5	2N3904	
R1-R5	47k	
R6	100k	
R7	15k	
R8	22k or 20k pot	
R9	47k	
R10	510k	
R11	150k	
R12	4.7k	
R13	47k	
R14	100k	
S1-S2	pushbutton switch, spst	
U1	ISD-1020A recorder ic	
Z1	ferrite bead, prestrung	

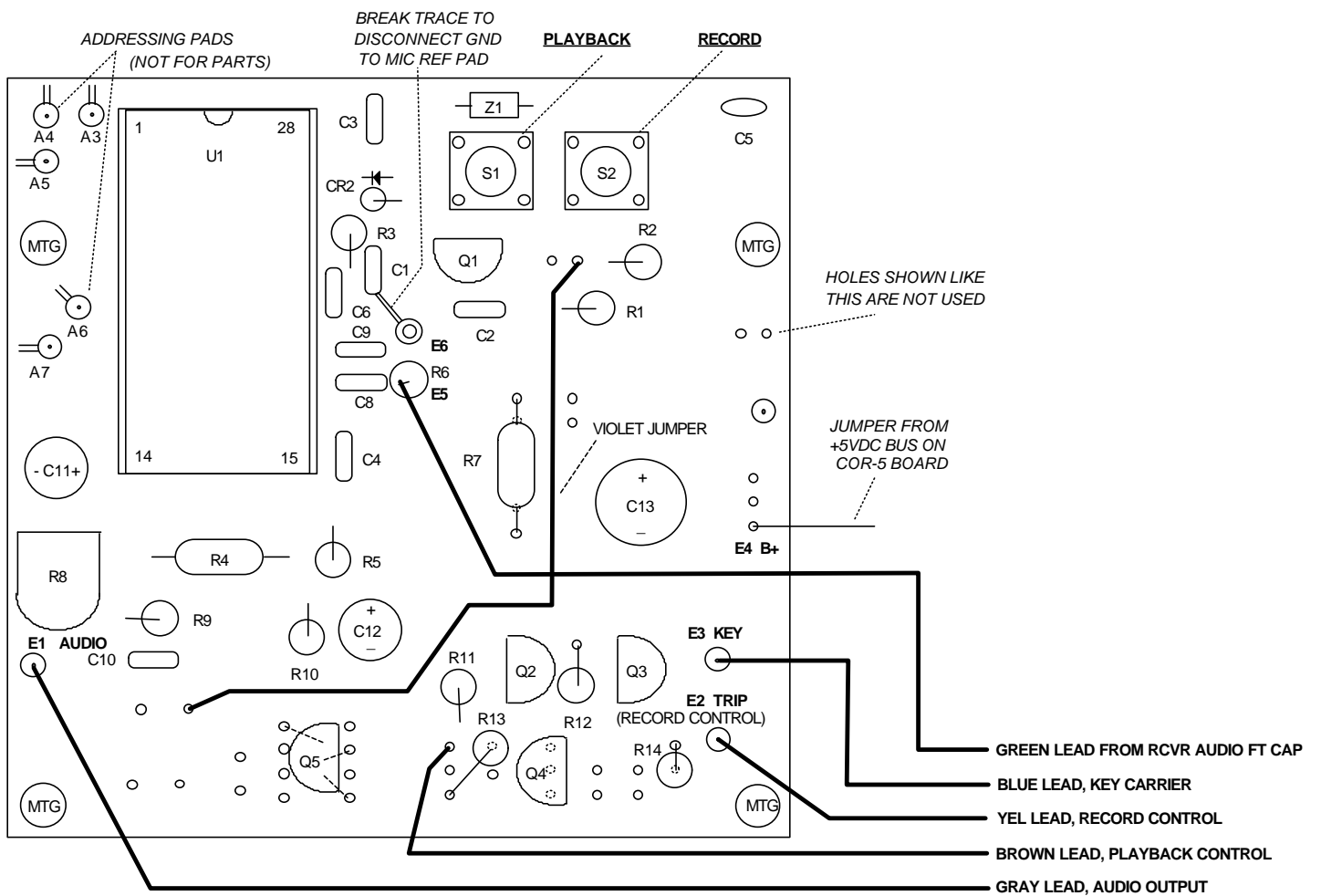

**DVR-3 DIGITAL VOICE RECORDER MODULE
COMPONENT LOCATION DIAGRAM**

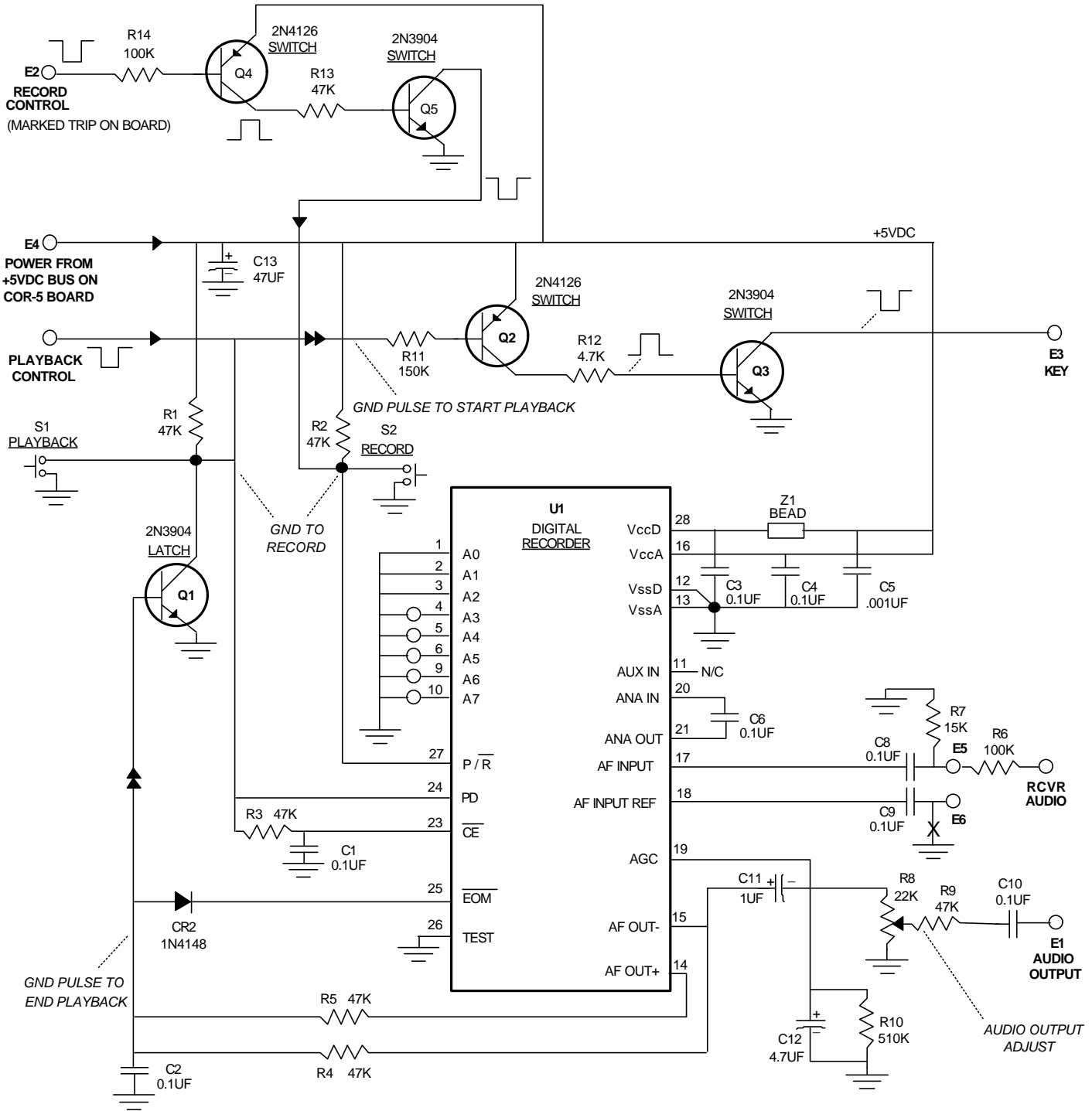

DVR-3 DIGITAL VOICE RECORDER MODULE