

HAMTRONICS® MO-96 PACKET RADIO NETWORKING MODEM: ASSEMBLY, INSTALLATION, OPERATION, AND MAINTENANCE

GENERAL DESCRIPTION.

The MO-96 is a radio modem designed to be used with special versions of our Transmitters and Receivers to provide a low-cost method of networking packet radio TNC's and other computer terminals at a data speed of 9600 baud. It may be used at data rates as low as 1200 baud; however, it is not practical for very low baud rates.

The MO-96 contains several low-pass filters to optimize the data waveform for transmission on NBFM channels, and it has provision for optional voice input. Adjustments are provided for transmit frequency and deviation. A voltage regulator provides frequency stability. A high current transistor switch turns on the exciter and pin-diode antenna switch at the command of the TNC.

The receiver section of the MO-96 board has a special data detector with a low-pass filter, peak detectors, a slicer, and digital AFC to lock quickly onto the received signal and provide data integrity. A special fast squelch circuit in the receiver provides a DCD handshake to the TNC.

The modular approach to building a radio modem with Hamtronics modules allows choice of frequency bands and power amplifier output levels. The system is transparent to the terminal to allow various protocols to be used. The transmitter is similar to our standard voice transmitters, except that it has provisions for direct fm modulation from a data input. The receiver is a modified version of our standard units with special filters for low group delay distortion. The receiver, itself, features special if filters with low group delay distortion. Note that our newer synthesized exciters can operate at 9600 baud directly, and only need the MO-96 to provide the key up circuit to respond to RTS.

The transmitter, receiver, and PA are all optimized for fast data transfer times. The PA's use diode switching for fast antenna transfer. The MO-96 is compatible with all TNC's which have an external modem connection provision.

Note that the system must be used with a TNC or terminal with a protocol which does not allow the data level to rest at one level for more than a few bits. The protocol must use bit-stuffing (as amateur TNC's do) to ensure that the data signal is constantly varying. This prevents the afc from swinging over to one side if the flow of data stops for a period of time.

THEORY OF OPERATION.

Refer to the schematic diagram. For use with crystal controlled exciters, data from the TNC is applied to U1-B, a summing amplifier, which combines a dc bias from frequency control R11 with the data input signal. R1 sets the magnitude of the data signal with respect to the bias, thereby allowing the frequency shift to be set relative to the center frequency, adjusted by R11. The output of U1-B is almost a pure square wave of about 2 V p-p with a dc offset of about +4.5V to center it in the desired range for the varicap diode in the transmitter. If this signal was applied directly to the modulator in the transmitter, the high frequency components of the square wave would cause splatter on the air; so further signal processing is required to keep the rf signal within the passband of a narrowband fm receiver. U1-C and U1-A are both low-pass filters, which effectively round off the square wave pulses to reduce the occupied bandwidth of the transmitted signal. Time constants of the filters are optimized for a 9600 baud data rate. Because the three op-amps are dc coupled, adjustment of R1 and R11 directly affect both the center voltage and the voltage swing of the output at E3, which drives the varicap modulator in the transmitter.

Sometimes, it is handy to be able to use voice on the transmitter, especially when setting up the link working with someone on the other end. E1 allows the output of the speech processing circuits in the exciter, which normally would drive the reactance modulator in the exciter, to drive the input of summing amplifier U1-B. If so connected, an external switch is needed to disconnect the voice signal path when not in use.

The discriminator signal from the receiver is processed through low-pass filter U1-D, which is similar to the ones in the transmit section. The time constant of the filter is optimized for 9600 baud signals. The resulting output is a rounded data signal similar to what is applied to the transmitter. This signal is applied to two circuits. The first is a peak detector, which uses emitter followers for current gain to drive electrolytic capacitors C10 and C11 with a fast-attack, slow-release time constant, charging them to the positive and negative signal peaks. The resulting voltages are summed through R21 and R22, producing an averaged dc signal representing the center of the data signal.

This dc signal is applied to the afc circuit in the receiver. It also provides a reference for slicer Q3/Q4.

The slicer accurately detects swings above or below the center of the signal voltage, producing a precisely detected square wave representing the data signal. Were it not for this elaborate detection scheme, any frequency drift in the transmitter or receiver would result in intolerable distortion of the data signal. The slicer output is applied to Q5, which switches a dc level of 0 to +5Vdc for application to the TNC.

U2 is a voltage regulator, which provides a stable source of +12V to operate the unit. It is especially important that the input voltage be high enough to allow for the required minimum voltage drop in the regulator so that the voltage in the transmitter circuit is stable, because the frequency accuracy of the transmitter depends on it. If the operating source is not at least 13.5V, the regulator should be removed and bypassed, and a stable source of +10 to +12V should be used.

Q6 is a high-current switch. It allows the transmitter to be keyed by the TNC, when required. Grounding the input at E9 switches on +13.6Vdc at up to 600 mA to operate the exciter. The PA normally is not keyed on and off. Being class C, it can remain powered up, drawing current only when it receives drive from the exciter. The switched dc at E10 could be used to operate a pin diode switch if the exciter is used bare foot without a PA.

CONSTRUCTION GUIDELINES.

The unit should be assembled with information from the parts location drawing and the parts list. There is no special construction sequence; but following are some notes regarding various parts.

a. Resistor bodies are designated as circles on the assembly diagram for those which are mounted vertically.

b. Observe the polarity of ic's, transistors, diodes, and electrolytic capacitors.

c. Trim pots may be marked with significant figures and multipliers, such as "503" for 50K or "202" for 2K. The value may even be marked with one significant figure and multiplier, such as "23" for 2K. There may be an additional, meaningless letter on the end.

d. Install an ic socket for U1. Then, plug in the ic, observing the notch on both the socket and the ic.

e. Cut the terminal pins from the metal flashing strip and press them into the holes for the terminals in the top of the board.

INSTALLATION.

Location.

The preferable location of the equipment is in a heated indoor area so that the transmitter is not exposed to a wide temperature range. The frequency stability of the transmitter is affected by the temperature of the varicap diode used in the modulator. If you must put the transmitter in an unheated area, some provision should be made to keep the temperature of the exciter within reason.

Other than that restriction, the only concern is to keep the MO-96 unit within a few feet of the transmitter and receiver to minimize noise on the analog lines to and from those units. If need be, the TNC can be some distance away because it only has digital connections.

Connections to MO-96 Terminals.

Following is a general discussion of the interface connections required to the MO-96 solder terminals. Connections can be made with ordinary hook-up wire to the terminal pins on the board. You can either wrap the wire around the pin or insert it into the open end of the pin and then solder. Specific connections depend on the units with which the MO-96 is used. If you are using the Hamtronics 220 MHz Exciter and Receiver, for instance, refer to the Instruction Sheet for the HS-220 Modification Kit for specific details. You should also refer to the manual for your TNC to determine how to connect to the TNC and how to disable the internal modem.

E1 Speech Input (optional). It may be handy to be able to use voice transmissions at times for testing with someone at the other end of the network link. Refer to the HS-220 or similar instruction sheet for details on how to rewire the output of the speech processing circuits in the Exciter to route the audio out to the MO-96. If you do this, provide a small switch of some sort to allow the audio to be disabled when not in use to minimize noise on the data signal.

E2 Data from TNC. Disable the internal modem in the TNC and connect the data output signal to E2. This should be a 0 to 5V square wave data signal. The MO-96 Modem at the other end of the link will regenerate the data signal for the other TNC with the same polarity as comes from your TNC to E2. (Note: The data input must be dc coupled. If you are using a TTL source instead of CMOS or

HCMOS, provide a 1K pull-up resistor to +5V to ensure full 5 volt swing.)

E3 Varicap in Transmitter. Connect this terminal through a short length of wire to the free end of the 47K resistor on the Exciter. (See HS-220 or similar mod. kit sheet for the TA51, TA451, or TA901 Exciter.) That terminal is connected to the varicap diode modulator input in the modified Exciter.

E4 Input from Receiver Discriminator. Connect a wire from E4 to the Discriminator output of the receiver.

E5 Data to TNC. Connect to the external modem data input terminal on your TNC. Signal level is 0 to +5Vdc.

E6 Receiver AFC. At one time, some of our receivers had afc, but newer ones do not need this. Normally, leave this output not connected.

E7 +13.6 Vdc Input. Connect to a source of regulated and filtered +13.6Vdc to +15Vdc. Note that the voltage regulator must have at least 13.6Vdc input to provide regulation, which is important for transmit frequency stability, as previously described. If your power supply is only 12Vdc but is well regulated, the voltage regulator on the MO-96 can be removed and jumpered out of the circuit.

E8 Ground. It is important to connect this terminal not only to the negative terminal of the power supply, but since it is the ground reference for all of the signals, a ground wire must be connected from E8 to the Exciter, Receiver, and TNC, as well.

E9 PTT from TNC. The PTT output of the TNC, which provides a ground to activate the transmit mode, should be connected to E9.

E10 Switched B+ to Exciter. Connect E10 to B+ input terminal E1 on the Exciter. If a PA is used, its B+ input should be connected to 13.6Vdc directly, not through this switched B+ line. (PA's only draw current when drive is applied.) If you are using an Exciter barefoot, a pin diode switch or one of our TRR relays can be powered by E10. Current rating of E10 is 600 mA maximum.

DCD Line from Receiver to TNC. In addition to the above connections to the MO-96 Modem, it is necessary to connect a wire from the squelch circuit in the receiver to the DCD input on the TNC to tell the TNC when a signal is received. (See HS-220 or equivalent Instruction Sheet for details.) The DCD wire should be soldered in the hole normally used for R25 in the R220 Receiver (R27 in the R451) which provides connection to the collector of the transistor normally used for hysteresis in the Receiver.

Thus, the transistor grounds the DCD line when a signal is received, providing carrier detect lockout and illuminating the "DCD" led on the TNC.

ALIGNMENT.

Receiver Module.

Align the Receiver as stated in its Instruction Manual. Align the channel oscillator to set it precisely on the channel frequency as done for voice operation.

Exciter Module.

Align the Exciter as stated in its Instruction Manual except do not align the carrier frequency as for normal voice operation. Instead, the resting frequency is set with R11 on the MO-96 Modem with a LO data input signal and the deviation is adjusted with R1, which sets the amount of frequency shift with a HI data signal. There are several ways to do this. Choose one which you can do with test equipment at hand.

Most precise method: Use a service monitor or other method of actually measuring the carrier frequency and deviation. The best way to do it is with the TNC actually sending data with "CALIBRATE" mode of TNC, adjusting R11 and R1 for both proper center frequency and deviation. Optimum signal-to-noise ratio occurs with a deviation of +/-4 to 5 kHz. That is a total frequency shift of 8 to 10 kHz from mark to space.

Note that if you are using our newer frequency synthesized exciter, simply adjust the audio gain control on the exciter to drive the limiter into limiting, and then adjust the limiter adjustment for the desired 4 to 5 kHz deviation level.

Method with only Frequency Counter: You can apply steady-state dc voltages of 0V and +5V to the E2 input terminal and measure the resulting frequency transmitted by the Exciter. Add and subtract the 4 or 5 kHz desired deviation from the desired center frequency to determine mark and space frequencies. Set R11 for the frequency with 0V applied to the input and set R1 for the shift to the other frequency with 5V applied.

Method with only Receiver as Monitor: Monitor the received signal with a scope at TP3 (top lead of R18) on the MO-96. Apply an alternating square wave to input terminal E2 on TNC output if a "CALIBRATE" test signal can be generated with the TNC. Set the combination of R11 and R1 for a data signal at TP3 of 4.5 V center with a swing of 4 V p-p (a low of 2.5V and a high of 6.5V).

Method without Immediate Access to Receiver: This is a kind of preliminary adjustment, which

roughly sets the deviation but not the frequency. Connect a dc voltmeter to output terminal E3 to measure the voltage applied to the varicap modulator. Apply 0Vdc to input terminal E2, and adjust R11 for +6.5Vdc at E3. Apply +5Vdc to E2, and adjust R1 for +2.5Vdc at E3. When contact is made with the receiving station, assuming it has been calibrated accurately, have them check your signal for proper frequency and deviation, using a scope at TP3 on their MO-96 as described above in the procedure for using the "Receiver as a Monitor".

Voice Modulation Alignment.

The mode previously described for voice operation really was not intended to be used all the time, so no concern was given to optimizing the modulation. It merely provides a cheap & dirty way to talk on the link for setup purposes. The normal ac coupled output of the speech processor in the Exciter is routed through a single-pole double-throw switch to allow either the normal data signal or the voice signal to be coupled to the input of U1-B in the MO-96 Modem. Doing it this way is easy, but the ac coupled audio signal will result in modulation centered at the resting frequency of the Exciter, not at the center of the receiver passband. This is quite ok for the purpose intended, but it means you won't be able to set the audio up for full deviation as you normally would for nbfm. Set the switch for voice input, turn the deviation limiter on the Exciter fully clockwise, and adjust the mic. gain control on the Exciter for acceptable sounding audio at the receiver. It's that simple.

OPERATION.

Once the system is set up, operation is automatically controlled by the TNC. The Exciter should transmit when the TNC grounds its PT line, and data should flow into the TNC at the opposite end of the link. The power amplifier operates class "C"; so it is powered up all the time and draws current only when the Exciter drives it.

The volume control on the Receiver can be turned all the way down for data operation. Set the squelch control clockwise just past the point where the "DCD" led on the TNC stays

off with no signal. Since the hysteresis transistor in the Receiver is used instead to operate the DCD circuit in the TNC, there will not be the normal hysteresis in the squelch action. Be sure not to set the squelch on the hairy edge; you must allow for small variations in operating conditions and don't want the squelch to hang open if something changes a little.

If a VOICE/DATA switch is installed, be sure to set it to DATA position for normal operation. For voice operation, set it to the VOICE position, and set the volume control to a comfortable level.

TROUBLESHOOTING.

Having read the Theory of Operation, you have a good understanding of how the circuits work. The best way to troubleshoot is to check for the following typical signal levels. Test points are indicated on the schematic and component location diagrams for major signal points in the circuits. Most measurements are made with an alternating square wave test signal applied from the TNC. A pseudo-random data generator is handy for testing eye patterns if you have one available. Many measurements can be made with a sensitive dc voltmeter; however, an oscilloscope is desirable, preferably a dual-trace scope.

Transmit Data Filter Circuit.

Input to E2 should be a 0 to +5Vdc data signal.

TP1 (top lead of R4): square wave data signal with about 2V p-p amplitude and +4.5Vdc offset (center) above ground. See figure 1. (If no scope available: With input to E2 open, the dc voltage should be adjustable with R11 from about 2.5 to 7Vdc at TP1.)

U1-B pin 5: biased at about +2.5Vdc.

U1-B pin 6: biased at 0 to 2.5Vdc (adjustable with R11) plus any signal voltage added through E2/R1.

U1-C pins 8&9: partially filter version of data signal, with about 2V p-p and 4.5Vdc offset, see figure 1.

U1-C pin 10: about 4.5Vdc with 2V p-p data signal.

TP2 (E3): completely filtered (bandwidth limited) data signal, rounded peaks, 2V p-p, 4.5Vdc offset. (Exact amplitude and offset depends on values needed for proper align-

ment of modulator; so do not align for these typical voltages.) See figure 1. To examine eye pattern at TP2, it helps to sync scope on input data clock or data signal at E2, using channel 2 of the scope or external sync input for sync.

U1-A pin 3: about 4.5Vdc with 2V p-p data signal.

Receive Data Circuits.

TP3 (top of R18): data signal, rounded peaks, about 4V p-p, +5Vdc offset. To examine eye pattern at TP3, it helps to sync scope on data output signal at TP4, using channel 2 of the scope or external sync input for sync.

U1-D pins 12 & 13: 4.5Vdc with 2V p-p data signal.

Q1-E: charges C10 to highest voltage peak of data signal.

Q2-E: charges C11 to lowest voltage (negative-going) peak of data signal.

E6: with on-frequency data signal received, about 4.5Vdc with only about 0.2V ripple.

Q4-C: square wave data signal, about +1 to +6V peaks.

TP4 (E5): square wave data signal, 0 to +5V peaks.

Transmit B+ Switch Circuit.

Base of Q6: 13.6Vdc with no input, 13.0Vdc with ptt line grounded.

E10: with normal load, 13.6Vdc with ptt line grounded and ground with ptt line open; if no load on E10, the voltage may float above ground with ptt line open, depending on leakage of transistor (a 1K load resistance should be enough to drain any leakage current for test.)

Current Drain: The current drain of the MO-96 Modem is very low, about 10-20 mA. However, since it switches power for the Exciter, the 500 mA or so of Exciter current will flow through the MO96 when the Exciter is keyed.

Method of Testing Unit without Exciter and Receiver.

If you want to test the MO-96 Modem without having the Exciter and Receiver in the circuit, simply loop the transmit output of E3 back to the receive input at E4. Since the levels are the same at these two ports, this loop technique may be used.

PARTS LIST, MO-96 MODEM.

Ref	Desig	Description (Marking)
C1-C6		.001 uF (102)
C7		0.15 uf mylar (red)
C8-C9		.001 uF (102)
C10-C11		4.7 uF electrolytic
C12		0.15 uf mylar (red)
C13		.001 uF (102)
C14		1 uF electrolytic
C15		47 uF electrolytic
Q1		2N3904
Q2-Q4		2N3906
Q5		2N3904
Q6		TIP-30 PNP, 1Amp
R1		20K pot.
R2		10K
R3		15K
R4-R9		10K
R10		4.7K
R11		2K pot.
R12		6.8K
R13-R14		10K
R15		2.2K
R16		10K
R17		1.2K
R18		560 ohms
R19-R22		15K
R23		1.2K
R24		6.8K
R25		2.2K
R26		1.2K
R27		4.7K
R28		1.2K
R29		330 ohms, 1/2W
U1		LM-324 Quad Op-amp
U2		78L12 Voltage Regulator
XU1		14 pin ic socket

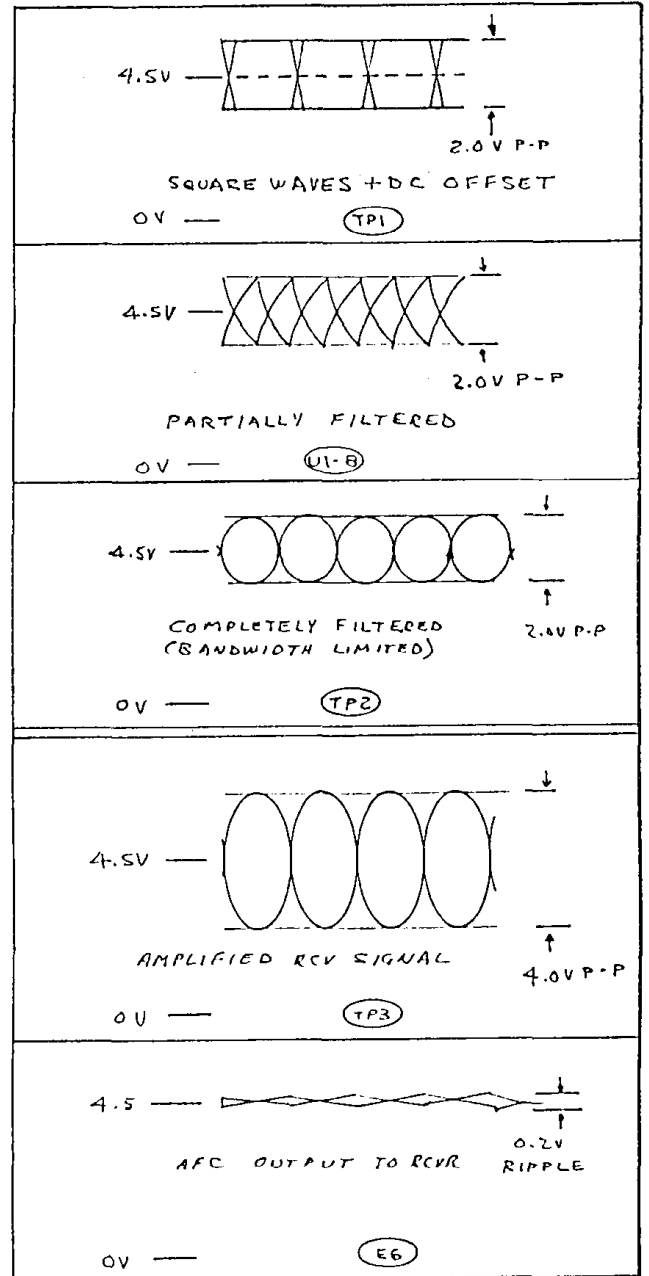
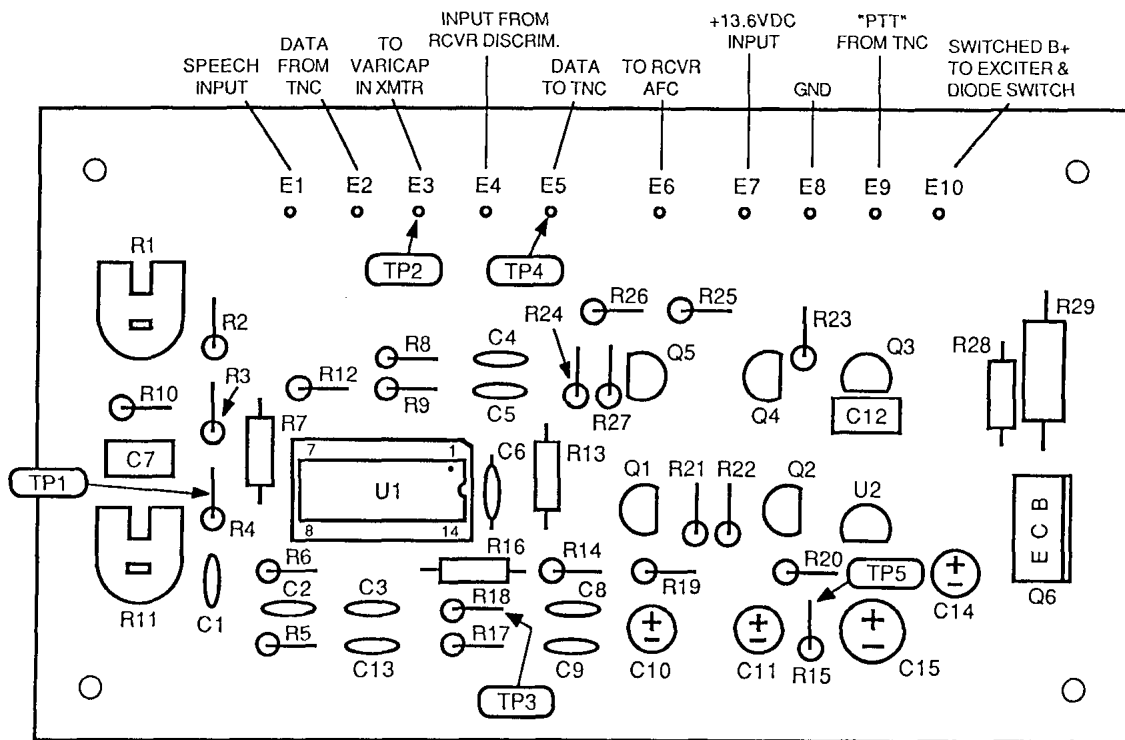
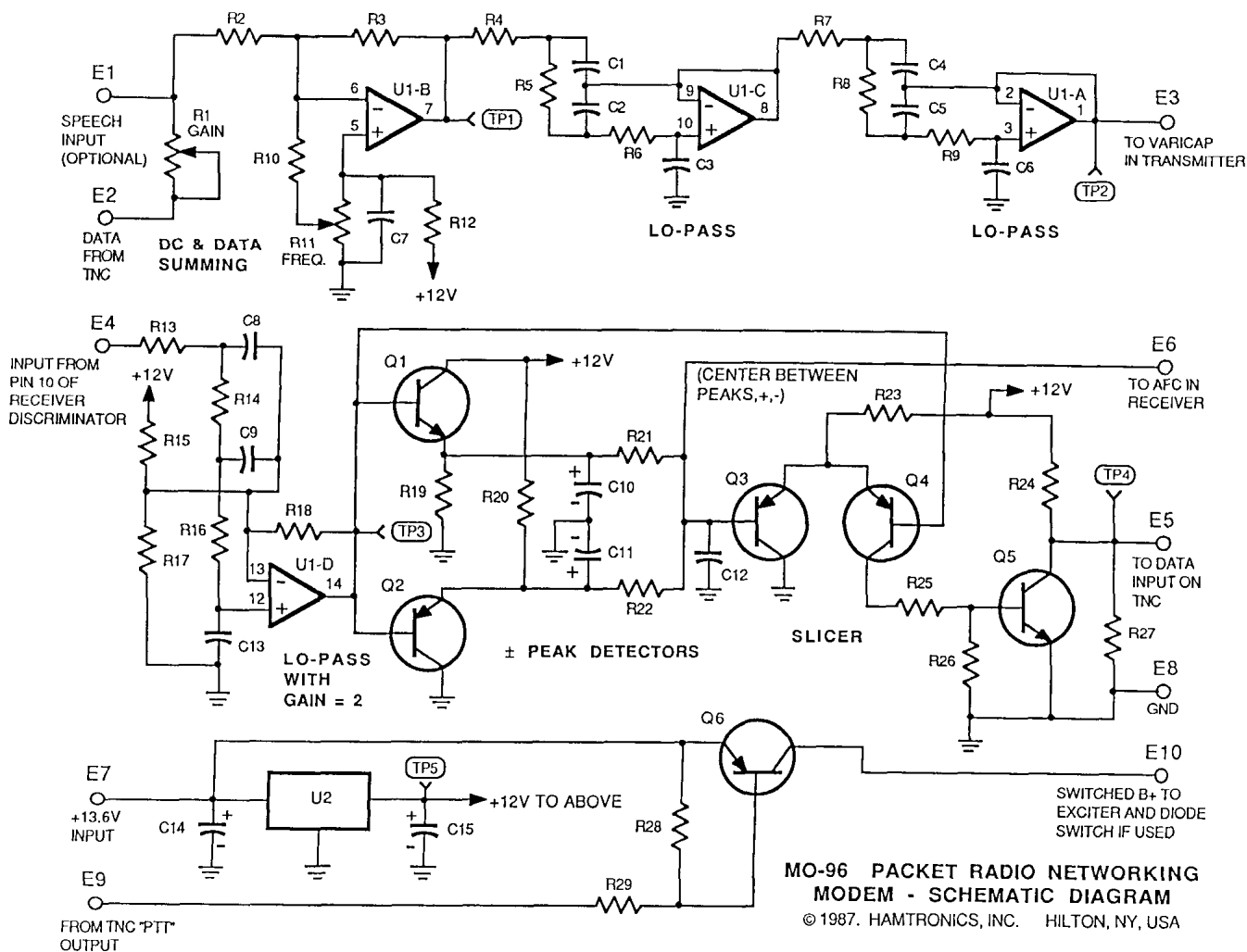

Figure 1. Waveforms at Major Circuit Points



MO-96 PACKET RADIO NETWORKING MODEM

© 1987. HAMTRONICS, INC. HILTON, NY, USA



MO-96 PACKET RADIO NETWORKING MODEM - SCHEMATIC DIAGRAM
© 1987. HAMTRONICS, INC. HILTON, NY, USA