

# HAMTRONICS® R122 VHF AIR BAND RECEIVER: INSTALLATION, OPERATION, AND MAINTENANCE

## GENERAL INFORMATION.

### Functional Description.

The R122 Receiver is designed for small airports to facilitate pilot control of lighting. The R122 Aviation Receiver builds on proven frequency synthesized receiver technology Hamtronics® vhf and uhf fm repeater receivers have been noted for. It is tunable over a range of 118-137 MHz in 25kHz increments. It uses triple-tuned circuits in the front end and ceramic filters in the i-f with steep skirts for good adjacent channel selectivity.

The R122 has one microcontroller which is responsible for watching the squelch to determine what is happening on the air. It responds to mic clicks as follows.

- Runway lights may be activated by keying the aircraft comm. radio microphone several times, typically three times in five seconds.
- If the airport is equipped with variable intensity lighting, the pilot can select intensities by keying the microphone 3, 5, or 7 times in a 5-second period.
- Lights remain on for a programmable period of time, usually 15 minutes.
- Various programming options allow for change in intensity after initial turn-on and flashing lights to warn of turnoff during last minute.
- Front panel LED indicates when lights have been activated at any intensity.
- A second LED indicates when the squelch is open.

**Table 1. Quick Reference**

**Frequency range:** 118-137 MHz  
**Channel spacing:** 25 kHz. Frequency set with dip switch; (repeaking coils required for freq change more than 2 MHz - use A28 tool)  
**Squelch sensitivity:** adjustable 2-35  $\mu$ V  
**12dB sinad sensitivity:** 2.5 $\mu$ V  
**Adjacent channel selectivity:** 60 dB  
**Image rejection:** 40dB (at +900kHz)  
**Other spurious rejection:** 50 dB  
**Temp stability:**  $\pm$ 10ppm +20 to +30° C;  $\pm$ 20ppm -30 to +50deg C.  
**Control outputs:** three separately controlled open-collector switching transistors able to sink up to 50 mA to ground on circuits up to 15Vdc. External solid state relays can be controlled for high current loads.  
**Antenna connector:** RCA jack on pcb (50 $\Omega$ ). UHF jack if installed in cabinet.  
**Power and control connections:** solder terminals on pc board  
**Size:** 4 in wide, 2.75 in deep, 1.25 in high.  
**Operating Power:** +13.6Vdc  $\pm$ 10% at approx. 45mA.

## INSTALLATION.

### Mounting.

Some form of support should be provided under the pc board, generally mounting the board with spacers to a chassis.

The receiver board relies on the mounting hardware to provide the ground connections to the ground plane on the board; so metal standoffs and screws should be used for mounting.

### Electrical Connections.

The antenna connection is made with a coaxial connector. All other connections are made at solder terminals on the pc board. Table 2 identifies the terminals used for these connections. The view of the pc board at the rear of the manual identifies the solder terminals on the pcb module.

Power and control signals should be connected to the unit with #22 solid hookup wire. Be careful not to route the wiring close to the components on the left hand side or rear of the pc board, which contains sensitive rf circuits which could pick up noise or be detuned from the wiring.

**Be sure to solder wires only on the bottom of the board.** A short circuit can be created by soldering on the top.

### Antenna Connections.

The antenna connection should be made to the pc board with an RCA plug of the low-loss type made for rf. We sell good RCA plugs with cable clamp. See A5 plug on website.

If you want to extend the antenna connection to a panel connector, we recommend using a short length of RG-174/u coax with the plug and keep the pigtailed very short.

We do **not** recommend trying to use direct coax soldered to board or another type of connector. The method designed into the board results in lowest loss practical. When soldering the cable, keep the stripped ends as short as possible.

### Power Connections.

The receiver operates on +13.6 Vdc  $\pm$ 10%. Current drain is about 50 mA. A well filtered power supply should be used. There is a voltage regulator on the board.

Be sure that the power source does not carry high voltage or reverse polarity transients on the line, since semiconductors in the receiver can be damaged. The positive power supply lead should be connected to the receiver at terminal E4 (marked +12V), and the negative power lead should be connected to the ground plane of the board

through the mounting hardware or soldered to the ground terminal on the board. Be sure to observe polarity to avoid damage!

### Optional 12Vdc Power Adapter.

The A40 adapter is rated for 12Vdc at 200 mA load. It is a filtered dc power source but is not regulated. Since there is a voltage regulator on the receiver board, a regulated power supply is not necessary, as long as it is a well-filtered supply.

The adapter actually puts out close to 18Vdc with no load and drops to about 15-16Vdc with the load a receiver presents.

To install the adapter, clip the ends of the leads off and strip them about ¼ inch. The lead with the small grooves molded into it is positive, and the smoother lead is negative.

The stripped leads can be soldered to the + power input and ground terminals of the pc board. *Be sure to observe polarity to avoid damaging the receiver module. Because it is difficult to tell the ribbed lead from the smooth lead, double check before applying power to the radio to avoid damage.*

### Control Outputs.

The R122 has three output transistors used to turn on one or more relays. These are called Output A, Output B, and Output C. Each transistor can sink as much as 50mA at voltages up to +15Vdc. In other words, the transistors switch ground on and off and can be used to ground the (-) end of a relay input.

**CAUTION:** *Be careful not to exceed the voltage or current capabilities of the transistors. Also, be very careful about transients generated by inductive loads, such as relays.* All relay coils must have a diode connected across the coil to absorb transients from inductive kickback, which can reach several hundred volts when the coil is switched off. See application diagrams, which follow, for examples of how to connect the diode, which basically must conduct any energy of reverse polarity; so the diode is connected backwards from regular polarity of the power source. Therefore, the diode does not conduct unless there is a reverse voltage. **NOTE THAT SOLID STATE RELAYS DO NOT HAVE A COIL; SO THEY DO NOT NEED A DIODE. SUCH RELAYS ARE PREFERRED BECAUSE THEY DO NOT PRESENT A DANGER TO THE RADIO.**

The relay should be mounted in an electrical cabinet for safety. If you use a solid state relay, it should be mounted on a metal surface for proper heatsinking. For instance, our A95 relay may be operated with a load up to 4Amp at room temperature with no heatsink. For operation at elevated temperatures or for load currents over 4 Amp (up to

10 Amp), the relay needs to be heat sunk to a large metal surface, and a good size electrical cabinet should provide ample surface for that.

To provide heatsinking for the relay, it must be mounted on a bare metal surface. If necessary, a large aluminum plate can be installed in the cabinet to provide bare metal for heatsinking. Before screwing the relay to the heatsink surface, spread a very thin layer of heatsink compound on the metal relay base to transfer the heat to the heatsink.

⚠ **CAUTION:** *Installer is responsible to ensure that proper heatsinking is provided. Warranty does not cover damage to relay which might result from improper installation.*

To allow pilot control of runway lights (PCL), the three output transistors are turned on by clicking the microphone button in the aircraft, as explained later under Operation. Three clicks in five seconds turns on Output A, five clicks turns on Output B, and seven clicks turns on Output C. The outputs can be used to control relays to turn on the ac power for the lights. Think about how you want the lights to operate before wiring the outputs. There are ways to provide different options, depending on the wiring. The three outputs can be used to control relays for three levels of lighting. (More information in Operation section.)

Figure 2 shows two ways to turn on large ac loads with the receiver. The preferred method is to use a modern solid state relay which can be controlled with a small dc current and switch large ac loads. Solid state relays can be obtained from Hamtronics as an accessory. Figure 2A shows how to wire a solid state relay, with the negative side of the control input switched by the output of receiver.

The older method of switching large loads is to use a small dc relay to turn on a large ac power contactor. This method is shown in figure 2B. Make sure that the smaller relay can be operated with less than 50mA of current, and be sure to place a reverse polarity diode across the coil to prevent inductive kickback from damaging the receiver. This diode can be almost any type, including 1N4148, 1N914, 1N4001.

### Reset Provisions.

In some installations, it may be desirable to reset the microcontroller used for PCL and ELT operation. For instance, you might want to have a switch on the unit to turn off run-

Function	Module Pin
Ground	screws
+12Vdc	E3
Output A	E4
Output B	E5
Output C	E6

way lights manually or you might want to reset the ELT alarm manually. In such a case, simply wire a pushbutton switch from ground to External Reset terminal E7 on the pc board. When you press the button, it will cause the microcontroller to reboot from scratch and reset everything to the starting condition.

## OPERATION.

### General.

The R122 has one microcontroller which is responsible for watching the squelch to determine what is happening on the air. Green LED D5, on the left, indicates when a signal is detected. Red LED D6, on the right, is used to indicate when one of the outputs is turned on by the receiver.

### Squelch Setting.

The squelch control, which is the small trim pot on the board, sets the threshold at which signals will be detected. Green LED D5, on the left, indicates when a signal is detected. It normally is lit when waiting for a signal (squelch closed) and it is extinguished when a signal is detected. The proper way to set the squelch threshold is to turn the pot ccw until the LED goes out and then turn it cw just past the point where the LED comes on again. Of course, do this when no one is transmitting.

**There may be installations where the default setting is too sensitive. If you get false triggering of the relay, try setting the squelch control a little more clockwise.** Since aircraft normally have line of sight communications with the airport, often times a receiver does not need maximum sensitivity.

### Mode Switch.

Seven position dip switch S2 (or jumper wires in newer units) is used to program the microcontroller which provides special features. In the following discussion, "1" indicates that a particular switch is ON or a jumper wire is installed and "0" indicates that

a switch is OFF or jumper wire is cut or not installed.

Note that newer units use jumper wires instead of dip switch because of difficulty getting switches. Jumper wires are really more reliable and tend not to be changed much; so it is a good tradeoff.

**Positions 1 and 2** set the mode of operation. The four possible modes are as follows:

0 0 = not used

0 1 = test mode

1 0 = not used

**1 1 = PCL mode (normal setting)**

**Position 3** is set to allow changes to be made by the pilot after initially turning on lights. If this switch is off, the receiver accepts only the first valid command until the timer expires, eg, 15 minutes. If this switch is on, the receiver will accept a new command while the timer is running, either another intensity or extending the current intensity.

**Position 4** is an optional setting for the PCL mode. It controls how the output responds during the last minute runway lights are on. If switch position 4 is turned on, the runway lights will flash during the last minute they are on to warn pilots that the lights are about to go out. If the switch is off, no flashing will occur; lights will simply turn off at the end of the timer period.

**Positions 5 through 7** set the time delay for turning off the lights in 5 minute increments. The switches set a three digit binary number which, multiplied by 5, is the time delay in minutes. Following are example settings:

000 = 1 min                      100 = 20 min

001 = 5 min                      101 = 25 min

010 = 10 min                      110 = 30 min

011 = 15 min                      111 = 35 min

Note that 000 sets it for one minute, an exception, handy for testing.

### Test Mode.

Turning on switch section 2 with section 1 turned off sets the microcontroller for a special test mode in which red LED D6 blinks on and off one cycle every two seconds. This al-

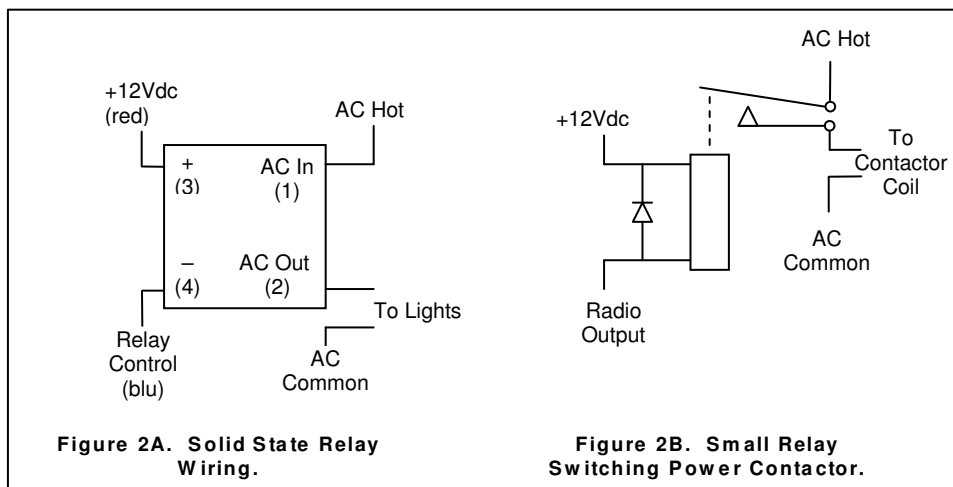

Figure 2A. Solid State Relay Wiring.

Figure 2B. Small Relay Switching Power Contactor.

lows a technician to check the controller clock accuracy, as there should be about 30 flashes per minute. Note that the controller clock is not as precise as a regular clock; so there may be a small variation in timing. This is normal. The purpose of the test is simply to see if the controller is running properly and that the clock is roughly accurate. The blinking will stop if the squelch is opened.

### Pilot Control of Lighting.

In the PCL mode, if a pilot clicks his push-to-talk button three, five, or seven times within five seconds, runway lights can be activated with Outputs A, B, and C, respectively. Depending on wiring, this can turn on runway lights at up to 3 intensity levels.

Programming the dip switch for PCL mode requires that switch sections 1 and 2 both be turned on. Switch position 3 allows for the option of letting the pilot make a change in settings once the lights are initially activated. Once the lights are activated, they will stay on for the length of time programmed with switch sections 5 through 7. Note that the timing system isn't precise; so if the time is too short, simply increase the setting until you get the about the length of time you want. Position 4 controls whether or not the lights flash during the final minute as a warning that they are about to go out.

When you install the system, carefully plan how you want the lights to respond to any possible condition. With the proper combination of programming and wiring the outputs to relays, you can make the lighting system operate smoothly and safely. Following are factors to be considered.

The receiver has the option of allowing changes to the command after an initial command is executed. If the switch is on, subsequent commands will be carried out, otherwise, they will be ignored until the time delay is completed for turning off the lights. If you do not allow changes and someone, even unintentionally, sends a command, they cannot carry out another command for 15 minutes or whatever the time delay is set for.

Red LED (D6) on the front of the receiver will illuminate anytime a command is in effect, that is, whenever one of the outputs is activated.

If you need to turn off the lights manually, you can use a reset switch, as explained in the Installation section. Resetting the controller effectively starts everything from scratch with the lights off.

### If you have problems turning on lights.

A few users have commented that they have trouble turning on lights sometimes or that the lights turn off early. Here are a few things to consider.

The number of clicks is important. You must send exactly the correct number of

clicks within 5 seconds. If you accidentally send more or fewer clicks, it won't turn on. Requiring 5 or 7 clicks is a bit harder to send accurately than 3 clicks; so most airports use 3 clicks.

The receiver responds to 3, 5, or 7 clicks. Just because you only wire one output to your relay does not mean the receiver won't respond to the other two commands. There are three outputs, one for each correct command. If someone sends one of the other commands, the receiver responds, but your relay does not turn on because it is not wired to that output.

Dip switch position 3 is turned on to allow changes to be made by the pilot after initially turning on lights. If this switch is off, the receiver accepts only the first valid command until the timer expires, e.g. 15 minutes. If this switch is on, the receiver will accept a new command while the timer is running, either another intensity or extending the current intensity.

Note that when one output turns on, the others turn off. For example, if you have your lights turn on with 3 clicks and someone sends 5 clicks after your lights are on, if you have dip switch 3 turned on to allow changes, the 5 click output will turn on and your 3 click output will turn off. This is so to allow the receiver to operate three different intensities of lighting, which is a scheme used at some airports.

The receiver may also pick up signals a pilot is sending to a nearby airport if they use the same frequency you do. So always consider that a command might be coming from someone other than a pilot using your airport. It is good to use a unique channel frequency for your receiver. Most of our customers order receivers for 122.800 or 122.900MHz. So if you use one of these channels for your receiver, so may another nearby airport.

If you are picking up signals from pilots far away, it may be that your receiver is too sensitive. Because aircraft have line of sight to the airport, signals can be received over a great range. Your antenna may be too effective (if you use a big antenna), or you may need to adjust the squelch sensitivity in the receiver to prevent weaker signals from activating the receiver. Refer to the section on Squelch Setting above.

## FREQUENCY SETTING.

### Opening Case.

If your receiver was supplied factory installed in a cabinet, remove the four screws on the *side* of the cabinet, and lift off the cover.

### General Procedure.

The channel frequency is determined by frequency synthesizer circuits, which use dip

switch S1 in conjunction with programming in microcontroller U1 to set the channel. The microcontroller reads the dip switch information and does mathematics, applying serial data to the synthesizer ic whenever power is applied. Following is a discussion of how to set the dip switch to the desired channel frequency.

**NOTE:** *If the frequency is changed more than about 1 MHz, a complete alignment of the receiver should be performed, as described in later text. Optimum operation only occurs if the synthesizer is adjusted to match the frequency switch setting and all the tuned amplifier circuits are peaked for the desired frequency.*

To determine what channel frequency to use, the microcontroller adds the frequency information from the dip switch to the 118 MHz "base" frequency.

Dip switch settings are binary, which means each switch section has a different weighting, twice as great as the next lower section. Sections have weights such as 25 kHz, 50 kHz, etc., all the way up to 12.800 MHz. (See Table 3 or the schematic diagram for switch values. Also see the shortcuts and tricks which follow this discussion.)

The system sounds cumbersome, but it really is fairly simple, and you don't need to do this frequently. (Also, see shortcut after this discussion.) A piece of paper or a small calculator is handy to aid in determining which sections of the switch to turn on. When done, you might want to record the switch settings in table 4 for future reference.

Begin by subtracting the base frequency, 118.000, from the desired frequency to determine the total value of all the switch sections required to be turned on.

If the difference is greater than 12.800 MHz, turn on switch #1, and subtract 12.800 from the difference frequency to determine the remainder. Otherwise, turn off switch #1.

Do the same for each of the other sections, from highest to lowest weighting, in sequence. Each time you consider the remainder, turn on the switch section with the highest weighting which will fit within the remainder without exceeding it. Each time it is found necessary to turn on a switch section, subtract the value of that section from the remainder to get the new remainder.

**As an example,** let us consider how to set the receiver for 127.325 MHz. The following discussion is broken down into steps so you can visualize the process easier.

a. 127.325 - 118.000 base freq. = 9.325 MHz remainder. Turn on switch #2, which represents the largest increment to fit remainder. Turn off switch #1 because its value is larger than 9.325.

b. 9.325 - 6.400 value of switch #2 = 2.925 MHz. Turn off switch #3, which is too large a value. Turn on #4, which is 1.600

MHz, the largest increment to fit the remainder.

c.  $2.925 - 1.600 = 1.325$  MHz remainder. Turn on switch #5, which has a value of 0.800 MHz (800 kHz).

d.  $1.325 - 0.800 = 0.525$  MHz (525 kHz) remainder. Turn on switch #6, which has a value of 400 kHz.

e.  $525 - 400 = 125$  kHz remainder. Now it is easy. Looking at the weightings of the switches, you can see that turning on switches 8 and 10 gives 125 kHz. Turn off switches 7 and 9, which are not needed.

f. When we finished, we had turned on switch sections 2, 4, 5, 6, 8, and 10. We turned off all the others. This can also be expressed as the binary number 0101110101.

**Note:** Dip switch information is read by the synthesizer only when power is first applied. If switch settings are changed, turn the power off and on again.

### Shortcut.

If you have access to the internet, our website has a long table of numbers which gives the equivalent binary number settings for every possible frequency. We couldn't print it here because it takes many printed pages of space. Surf to our website at [www.hamtronics.com](http://www.hamtronics.com) and look for Dip Switch Freq Programming for R121/R122 Aviation Rcvr near the bottom of the Table of Contents.

Look up the frequency, and it will give you all the binary switch settings. The address is case sensitive, and you must enter the address carefully, exactly as shown.

Also, here are settings for two common frequencies:

122.800 MHz = 0011000000

122.900 MHz = 0011000100

Note that it is easy to do frequencies just above 122.800 just by adding the least significant digits on the right. See that for 122.900, we just add the setting to increase the frequency 100 kHz above 122.800.

## ALIGNMENT.

### General Information.

Following are three alignment procedures. The first is alignment of the frequency synthesizer and receiver front end (rf amplifier and mixer). This must be done whenever the channel frequency is changed by more

Table 3. Frequency Settings	
Device	Frequency Weight
Switch #1	12.800 MHz
Switch #2	6.400 MHz
Switch #3	3.200 MHz
Switch #4	1.600 MHz
Switch #5	800 kHz
Switch #6	400 kHz
Switch #7	200 kHz
Switch #8	100 kHz
Switch #9	50 kHz
Switch #10	25 kHz

than 1 MHz. The R122 is a high performance receiver and is designed to be very selective. Therefore, retuning is necessary for optimum performance. The second procedure is alignment of the i-f stages, which normally is only necessary if some parts are replaced. The third procedure is trimming the crystal oscillator to exact frequency, which should be done once each year or two to compensate for crystal aging.

### Equipment Needed.

Equipment needed for alignment is a sensitive dc voltmeter and a stable and accurate communications service monitor for the channel frequency

The slug tuned coils in the receiver should be adjusted with the proper hex tuning tool to avoid cracking the powdered iron slugs. Variable capacitors and i-f transformers should be adjusted with a plastic tool having a small metal bit.

### Opening Case.

If your receiver was supplied in a cabinet, remove the four screws on the *side* of the cabinet, and lift off the cover.

### Channel Frequency Alignment.

Alignment is needed whenever the frequency is changed by more than about 1 MHz. Alignment ensures that the frequency synthesizer is optimized at the center of the vco range and that all stages are tuned to resonance.

a. Set dip switches for desired frequency.

b. Connect dc voltmeter to Osc Tune test point TP1 (pad on top of pcb). Adjust vco coil L1 for +2Vdc. (Although the vco will operate over a wide range of tuning voltages from about 1V to 5V, operation is optimum if the vco is adjusted to 2V.)

c. Connect dc voltmeter to buffer TP2 (pad on top of pcb). Adjust buffer coil L2 for a peak.

c. Connect dc voltmeter to RF Tune test point TP4 (pad on top of pcb).

d. Connect service monitor signal generator output to J1 using a coax cable with RCA plug. Adjust signal generator to exact channel frequency, and set it for carrier output only.

e. During tuning, adjust service monitor signal output level as needed to get an indication within the range of the noise detector driving the test point for the voltmeter. Note that the test point level will be effective for tuning only with a relatively weak signal and will saturate with too strong a signal. Basically, you are reading the noise level in the squelch circuit.

f. Adjust L4, L5, L6, L7, L8, and T1 for minimum voltage. Voltage goes down, not up, with increased signal level (trying to minimize noise).

### Alignment of I-F Stages.

a. Connect dc voltmeter to TP5 on top of pcb.

b. With no input signal (just noise), adjust if transformer T3 for +2Vdc on the meter.

⚠ Be careful not to turn the slug tight against either the top or bottom because the winding of the transformer can be broken.

### Oscillator Trimming.

Once each year, the crystal oscillator should be checked and adjusted back on frequency. Crystals normally age a little every year, with most of the aging change occurring in the first year.

a. First, perform step b of the Channel Frequency Alignment procedure to be sure vco is set to frequency.

b. Set the service monitor for 10.695 MHz above the channel frequency of the receiver. Connect sniffer antenna to receive input on service monitor and set attenuator for maximum sensitivity so you can pick up the oscillator signal from the R122.

c. Observe the frequency meter on the service monitor, and adjust trimmer capacitor C16 on the R122 for correct frequency indication on monitor.

## THEORY OF OPERATION.

The R122 is a frequency synthesized vhf fm receiver, the design of which was chosen because of its vastly superior squelch action compared to an am receiver. However, since am audio is not detected, the receiver does not have a speaker output. It is optimized only for control, not for monitoring audio. Refer to the schematic diagram for the following discussion.

Low noise dual-gate mos fet's are used for RF amplifier Q4 and mixer Q5. The output of the first mixer is coupled through 10.695 MHz transformer T1 to the second mixer, which is in U3.

U3 provides IF amplification, a 2<sup>nd</sup> mixer to convert to 455 kHz, an fm detector, and squelch. Ceramic filter FL2 provides adjacent channel selectivity at 455 kHz.

The output of the fm detector at pin 9 of U3 is applied to an active filter stage, which is peaked at 10,000 Hz, looking for noise when there is no signal. The noise output is detected by D3/D4 and drives the squelch detector input at pin 12. A variable dc voltage from Squelch trim pot R21 is also applied to pin 12 through a summing circuit to allow squelch threshold adjustment.

Table 4. My Switch Settings										
Frequency: _____										MHz
Switch Sections Turned On: (circle)										
1	2	3	4	5	6	7	8	9	10	

The COS (carrier operated squelch) signal from pin 13 drives the /IRQ input on microcontroller U4 to indicate when a signal is detected. It also turns the COS output at U3 pin 14 on and off to illuminate Squelch green LED D5 when no signal is present to allow the Squelch pot to be properly set.

The injection frequency for the first mixer is generated by vco (voltage controlled oscillator) Q2. The injection frequency is 10.695 MHz above the receive channel frequency. The output of the vco is buffered by Q3 to minimize effects of loading and voltage variations of following stages from modulating the carrier frequency. The buffer output is applied through a double tuned circuit to gate 2 of mixer Q5.

The frequency of the vco stage is controlled by phase locked loop synthesizer U2. A sample of the vco output is applied through the buffer stage and R3 to a prescaler in U2. The prescaler and other dividers in the synthesizer divide the sample down to 5kHz.

A reference frequency of 10.240 MHz is generated by a crystal oscillator. The reference is divided down to 5 kHz. The two 5kHz signals are compared to determine what error exists between them. The result is a slowly varying dc tuning voltage used to phase lock the vco precisely onto the desired channel frequency.

The tuning voltage is applied to carrier tune varactor diode D1, which varies its capacitance to tune the tank circuit formed by L1/C20/C26. C13 limits the tuning range of D1. The tuning voltage is applied to D1 through a third order low pass loop filter, which removes the 5kHz reference frequency from the tuning voltage to avoid whine.

Serial data to indicate the desired channel frequency and other operational characteristics of the synthesizer are applied to synthesizer U2 by microcontroller U1. Everything the synthesizer ic needs to know about the band, division schemes, reference frequency, and oscillator options is generated by the controller. Information about the base frequency of the band the receiver is to operate on and the channel within that band is calculated in the controller based on information programmed in the eeprom on the controller and on channel settings done on dip switch S1. Whenever the microcontroller boots at power up, the microcontroller sends several bytes of serial data to the synthesizer, using the data, clock, and /enable lines running between the two ic's.

Some of the 10.240MHz signal generated in U2 is used for the injection to second mixer at U3 pin 1.

Microcontroller U4 provides the intelligence to control runway lights. It senses squelch openings at interrupt pin 19, and its three outputs drive switching transistors Q6, Q7, and Q8. These transistors are capable of

driving external relays and may be used in other ways as described in the Installation section. Care must be used to avoid reverse polarity, overvoltage, and transients, all which can damage the transistors.

+13.6Vdc power for the receiver is applied at E4. U5 is a 5V regulator to provide stability and C49 eliminates noise. Additional filtering for the vco and buffer stages is provided by capacitance amplifier Q1, which uses the characteristics of an emitter follower to provide a very stiff supply, eliminating any possible noise on the power supply line.

## TROUBLESHOOTING.

### General.

The usual troubleshooting techniques of checking dc voltages and signal tracing with an RF voltmeter probe and oscilloscope will work well in troubleshooting the R122. DC voltage charts and a list of typical audio levels are given to act as a guide to troubleshooting. Although voltages may vary widely from set to set and under various operating and measurement conditions, the indications may be helpful when used in a logical troubleshooting procedure.

### Current Drain.

Power line current drain normally is about 45 mA.

If the current drain is approximately 100 mA, check to see if voltage regulator U5 is hot. If so, and the voltage on the 5V line is low, there is a short circuit on the +5Vdc line somewhere. U5 limits the short circuit current to 100mA to protect the receiver from damage. If you clear the short circuit, the voltage should rise again. U5 should not be damaged by short circuits on its output line; however, it may be damaged by reverse voltage or high transient voltages.

### RF Signal Tracing.

If the receiver is completely dead, try a 10.695 MHz signal applied to through a .01uf blocking capacitor to pin 16 of U3. You should be able to detect a 10  $\mu$ V signal.

Also, check the 10.240 MHz oscillator with a scope or by listening with a service monitor.

A signal from the service monitor on the channel frequency can be injected at various points in the front end. If the mixer is more sensitive than the RF amplifier, the RF stage is suspect. Check the dc voltages looking for a damaged fet, which can occur due to transients or reverse polarity on the dc power line. Also, it is possible to have the input gate (gate 1) of the RF amplifier fet damaged by high static charges or high levels of RF on the antenna line, with no apparent change in dc voltages, since the input gate is normally at dc ground.

## Synthesizer Circuits.

Following is a checklist of things to look for if the synthesizer is suspected of not performing properly.

a. Check the output frequency of the vco buffer. You should be able to pick it up with a sniffer antenna on the service monitor. It should be 10.695 MHz above the channel frequency.

b. Check tuning voltage at TP1. It should be about +2Vdc. Actual range over which the unit will operate is about +1Vdc to just under +5Vdc. However, for optimum results, the vco should be tuned to allow operation at about +2Vdc center voltage.

c. Check the operating voltage and bias on the vco and buffer.

d. Check the 10.240 MHz oscillator at pin 2 of the synthesizer. A scope should show strong signal (several volts p-p) at 10.240 MHz.

e. Check the oscillator at pin 1 of microcontroller ic U1 with a scope. There should be a strong ac signal (several volts p-p) at the oscillator frequency.

f. The data, clock, and latch enable lines between the microcontroller and synthesizer ic's should show very brief and very fast activity, sending data to the synthesizer ic shortly after the power is first applied. Because this happens very fast, it can be difficult to see on a scope. Use 100  $\mu$ Sec/div, 5Vdc/div, and NORMAL trigger.

g. Check microcontroller U1 to see that /reset line at pin 20 is held low momentarily when the power is first applied. C17 works in conjunction with an internal resistor and diode in the ic to charge slowly when the power is applied. It should take about a second to charge up.

h. Check the switch settings to be sure you have the correct frequency information going to the microcontroller. Check each of the output lines of the switch to verify that the voltage actually is present.

### Audio Output.

The audio output from the discriminator in U3 is available at T5. If helpful for servicing, you can connect this test point through a blocking capacitor to the audio input of a service monitor to listen to the detected signal. The audio is not de-emphasized, so it will sound a bit tinny.

### Typical Dc Voltages.

Tables 4-6 give dc levels measured with a sensitive dc voltmeter on a sample unit. All voltages may vary considerably without necessarily indicating trouble. The charts should be used with a logical troubleshooting plan. All voltages are positive with respect to ground except as indicated.

Use caution when measuring voltages on the surface mount ic. The pins are close together, and it is easy to short pins together

and damage the ic. We recommend trying to connect meter to a nearby component connected to the pin under question. Also, some pins are not used in this design, and you can generally not be concerned with making measurements on them.

Table 4. Typical Test Point Voltages		
TP1	Tuning V.	Normally set at +2V
TP2	Buffer	varies, but less than 1Vdc
TP4	RF Tune	varies with noise level, less than 2Vdc
TP5	Disc Audio	+2Vdc center, audio from fm detector

Table 5. Typical Xstr DC Voltages					
Xstr	Stage	E(S)	B(G1)	C(D)	G2
Q1	dc filter	4.3	4.9	5	-
Q2	vco	1.4	2.1	4.3	-
Q3	buffer	0	0.7	3	-
Q4	rf ampl	0	0	4.8	0
Q5	mixer	0	0	4.8	0
Q6-Q8	on	0	0	0.7	* -
	off	0	0	*	-

\* depends on circuit being switched

Table 6. Typical U3 DC Voltages			
Pin 1	4.8	Pin 9	2 (aligned)
Pin 2	4.5	Pin 10	0.75
Pin 3	4.8	Pin 11	1.5
Pin 4	5	Pin 12	0.6 (with squelch just closed)
Pin 5	4.5	Pin 13	0 (sq open)
Pin 6	4.5	Pin 14	3 (sq open)
Pin 7	4.5	Pin 15	0
Pin 8	5	Pin 16	1.8

## PARTS LIST.

Following are notes specific to certain parts.

① R40 is installed under board in parallel with LED D5 (tack solder to pads for LED).

② Microcontrollers must be factory programmed for each application, and they are not interchangeable.

⚡ Caution: Ic's and fet's are static sensitive. Use appropriate handling precautions to avoid damage.

Ref Desig	Description (marking)
C1	100µf electrolytic
C2	0.1µf
C3	100µf electrolytic
C4	0.1µf
C5	390pf
C6	.01µf
C7	.001µf
C8	100µf electrolytic
C9	100pf
C10	0.1µf
C11	390pf
C12	0.15µf mylar
C13	10pf
C14-C15	2pf
C16	20pf var cap
C17	1µf electrolytic
C18	15pf
C19	27pf
C20	15pf
C21	39pf
C22	100µf electrolytic
C23	390pf
C24	4pf
C25	62pf
C26	68pf
C27	390pf
C28	27pf
C29	4pf

C30	82pf
C31-C32	0.2pf
C33	100pf
C34-C35	30pf
C36	27pf
C37	39pf
C38	0.1µf
C39	.001µf
C40	390pf
C41	.01µf
C42	1µf electrolytic
C43	390pf
C44	.001µf
C45	.01µf
C46-C48	0.1µf
C49	100µf electrolytic
C50-C51	0.1µf
C52	1µf electrolytic
D1	BB132 varactor diode
D2	MMBT5179 used as diode
D3-D4	MMBT3904 used as diode
D5	Green T1 LED
D6	Red T1 LED
FL2	455kHz ceramic filter, type "LT-455-D"
J1	RCA jack
L1-L2	2½ turn slug-tuned coil
L3	0.33µH RF choke (red-sil-orn-orn)
L4-L8	2½ turn slug-tuned coil
L9	0.33µH RF choke (red-sil-orn-orn)
Q1	MMBT3904
Q2-Q3	MMBT5179
Q4-Q5 ⚡	BF998 MOS FET
Q6-Q8	MMBT3904
R1	27Ω
R2	1K
R3	180Ω
R4	27Ω
R5	47K
R6	470Ω
R7	10K
R8	27Ω
R9-R10	10K

R11	2meg
R12	3.9meg
R13-R14	10K
R15	47Ω
R16	180Ω
R17	3.9K
R18	47K
R19	2.2K
R20	47K
R21	20K trim pot.
R22-R23	100K
R24	6.8K
R25	1K
R26	180Ω
R27	47Ω
R28	4.7K
R29	680Ω
R30	470Ω
R31	510K
R32	470Ω
R33	3.3K
R34	27Ω
R35	3.3K
R36	47K
R37	1 meg
R38	3.3K
R39	47Ω
R40 ①	47K
S1	10 pos. dip switch
S2	7 pos. dip switch
T1	10.7MHz IF xfmr T1005
T3	455kHz IF xfmr T1003
U1 ⚡ ②	MC68HC705J1A µC *
U2 ⚡	LMX1501A synthesizer
U3	MC3361P
U4 ⚡	MC68HC705J1A µC *
U5	78L05ACD regulator
Y1	10.240 MHz crystal

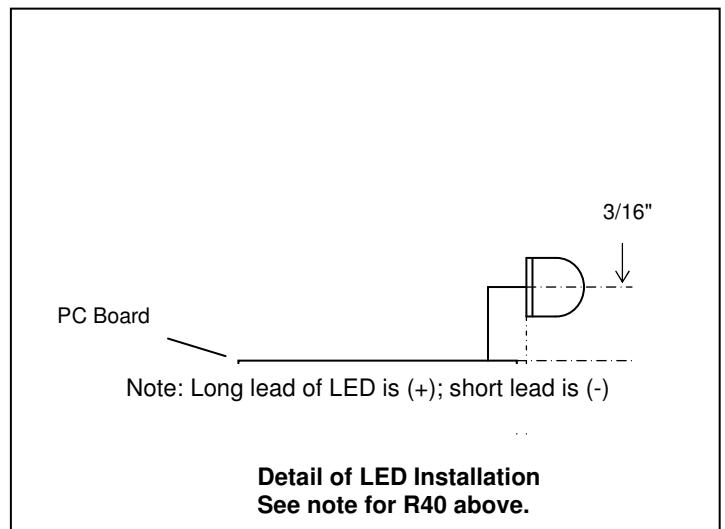

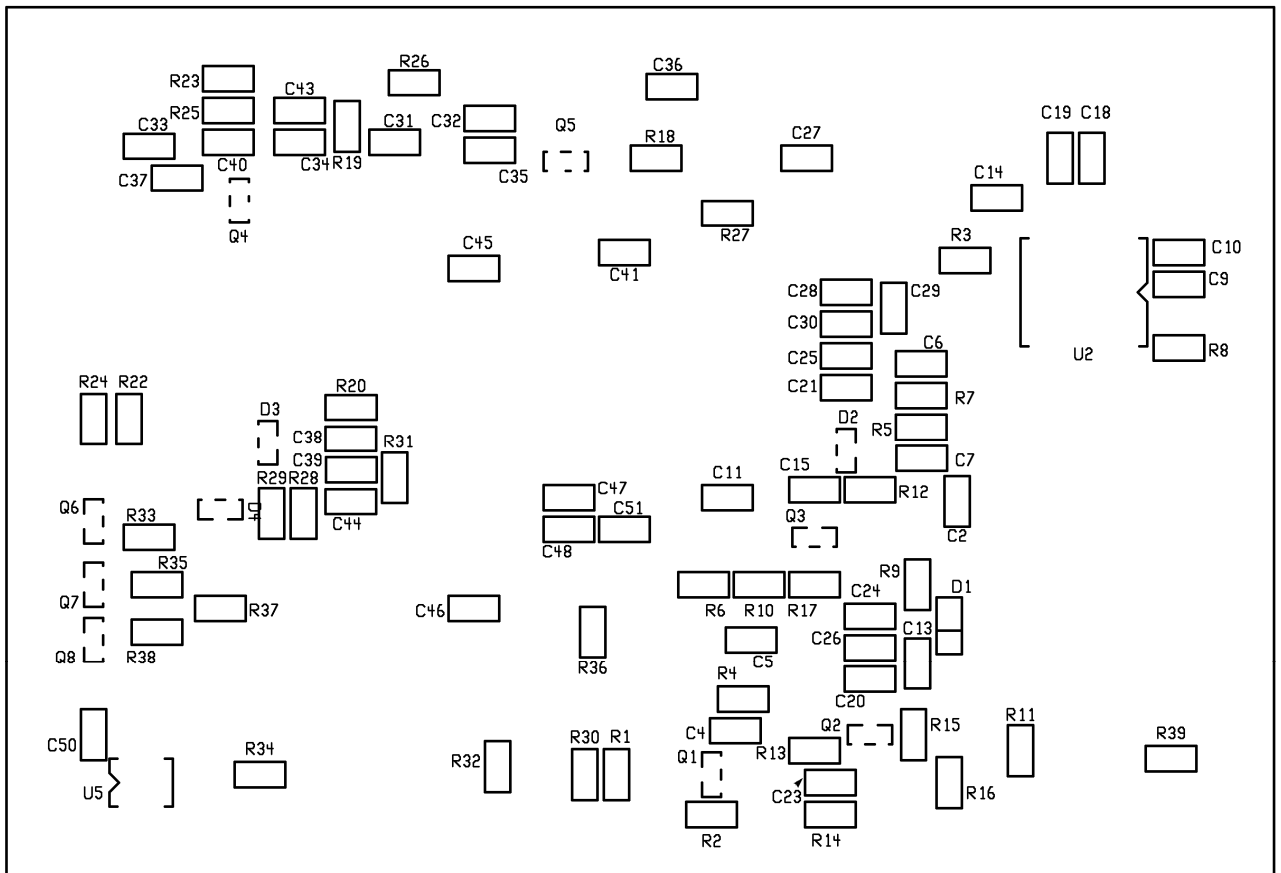
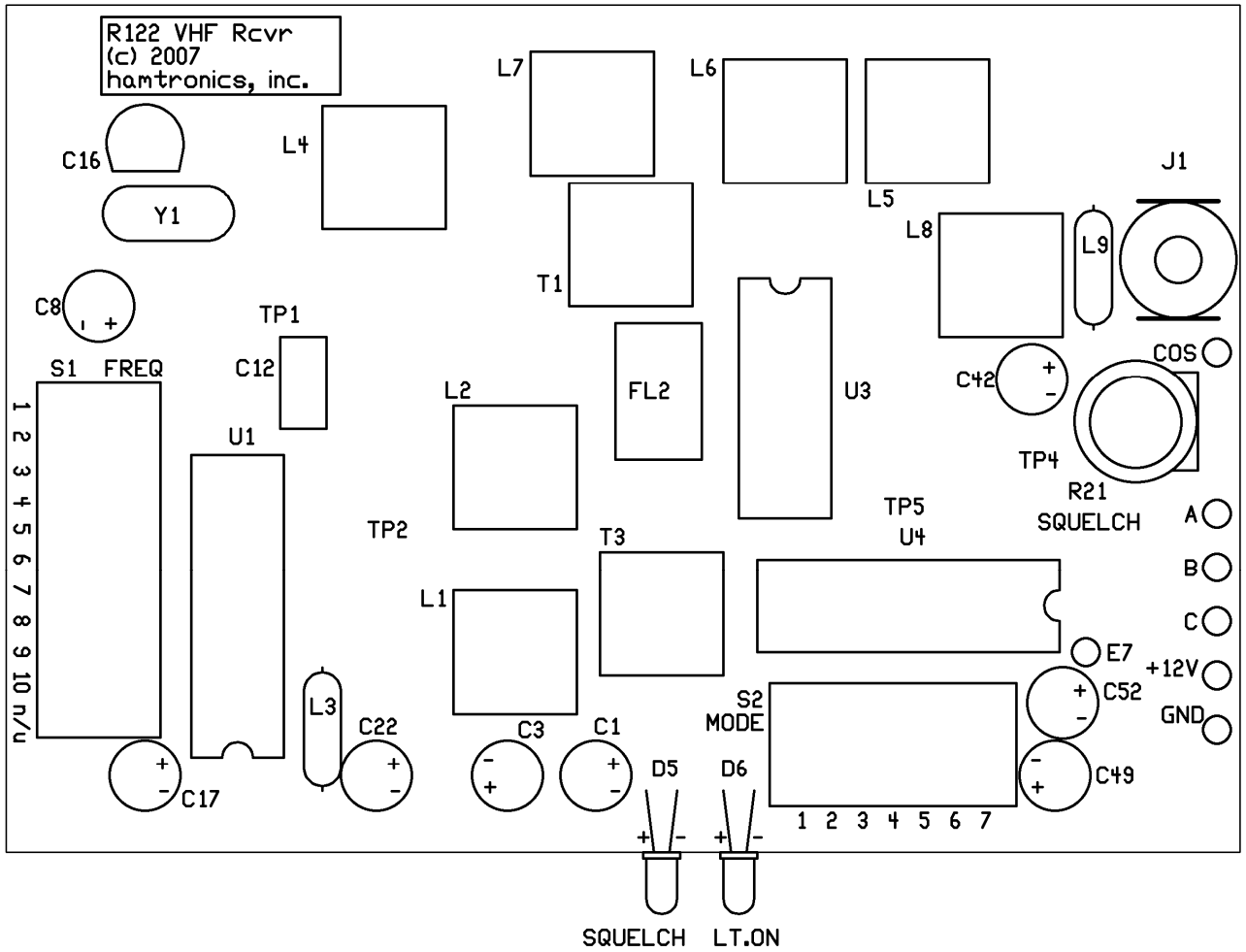



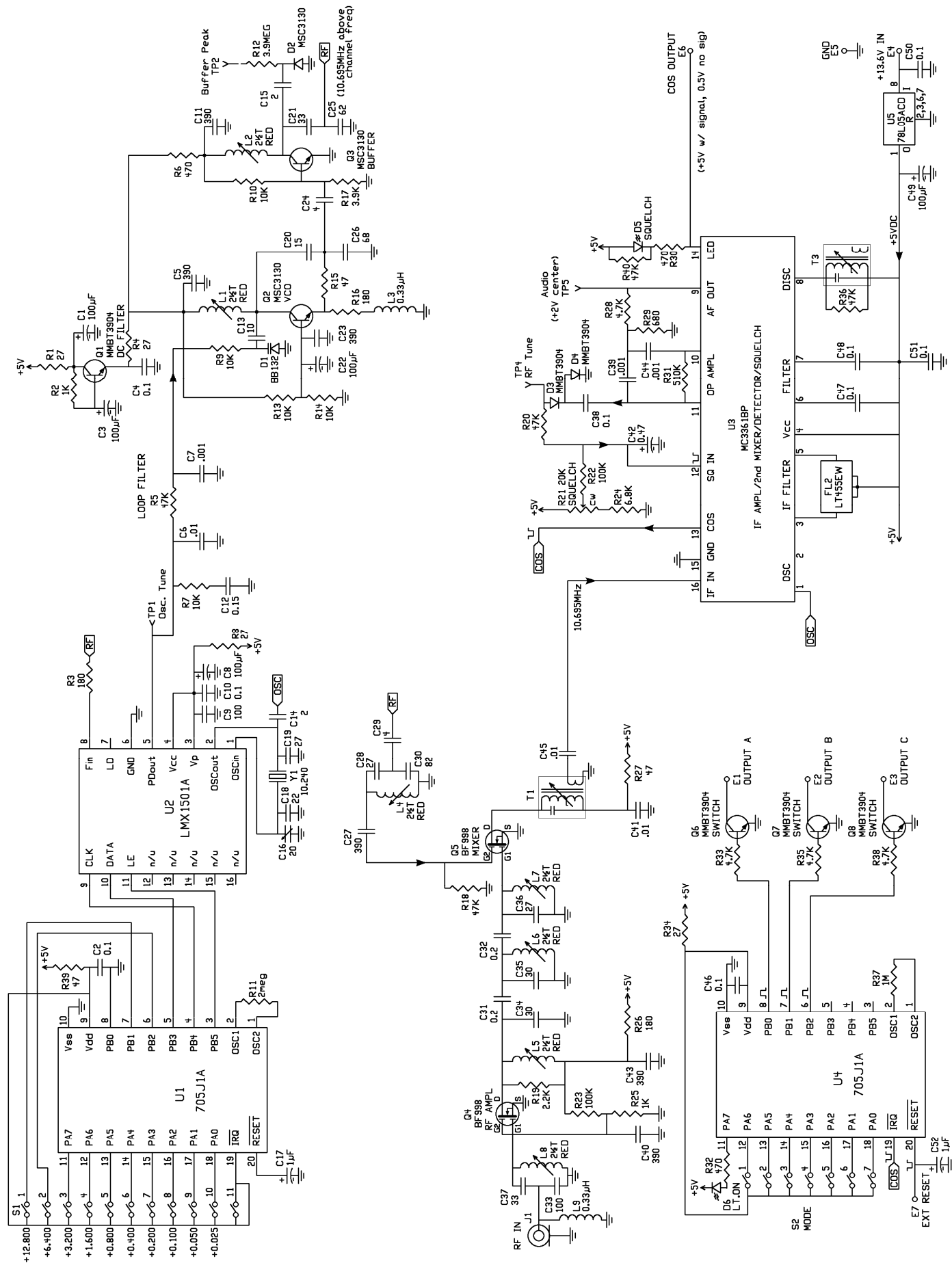

R122 VHF Receiver, Schematic Diagram.