

# HAMTRONICS® R123 VHF RUNWAY LIGHT CONTROLLER: INSTALLATION, OPERATION, & MAINTENANCE



## GENERAL INFORMATION.

### Functional Description.

The R123 Receiver is designed for small airports to facilitate pilot control of lighting. It builds on proven frequency synthesized receiver technology Hamtronics® vhf and uhf fm repeater receivers have been noted for. It is tunable over a range of 118-137 MHz in 25kHz increments. It uses triple-tuned circuits in the front end and crystal and ceramic filters in the i-f with steep skirts for excellent adjacent channel and out-of-band selectivity.

The R123 has a microcontroller which is responsible for watching the squelch to determine what is happening on the air. It responds to mic clicks as follows.

- Runway lights may be activated by keying the aircraft comm. radio microphone several times, typically three times in five seconds.
- If the airport is equipped with variable intensity lighting, the pilot can select intensities by keying the microphone 3, 5, or 7 times in a 5-second period.
- Lights remain on for a specific period of time, usually 15 minutes.
- A dip switch option permits change in

**Table 1. Quick Reference**

<b>Frequency range:</b> 118-137 MHz
<b>Channel spacing:</b> 25 kHz. Frequency set with dip switch; (repeaking coils required for freq change more than 2 MHz - use A1 tool)
<b>Squelch sensitivity:</b> adjustable 0.3 - 2 $\mu$ V
<b>12dB sinad sensitivity:</b> 0.3 $\mu$ V
<b>Adjacent channel selectivity:</b> 100 dB
<b>Image rejection:</b> 60-70dB
<b>Temp stability:</b> $\pm$ 2ppm -30°C to +60°C
<b>Control outputs:</b> three separately controlled open-collector switching transistors able to sink up to 50 mA to ground on circuits up to 15Vdc. External solid state relays can be controlled for high current loads.
<b>Antenna connector:</b> RCA jack (50 $\Omega$ )
<b>Power and control connections:</b> solder terminals on pc board
<b>Size:</b> 4 in wide, 3 in deep, 1.25 in high.
<b>Operating Power:</b> +13.6Vdc $\pm$ 10% at approx. 50mA, depending on audio level

intensity after initial turn-on. Front panel LED indicates when lights have been activated at any intensity.

- A second LED indicates when the squelch is open.

The R123 Receiver has an audio output; however, this is an fm receiver, not am, to provide excellent squelch carrier detection; therefore, even though you can listen to the channel, it will not detect am signals as an ordinary aircraft receiver will. You will be able to hear if there is a signal or any interference on the channel.

## INSTALLATION.

### Mounting.

Some form of support should be provided under the pc board, generally mounting the board with standoffs to a chassis.

The receiver board relies on the mounting hardware to provide the ground connections to the ground plane on the board; so metal standoffs and screws should be used for mounting.

### Electrical Connections.

The antenna connection is made with a coaxial connector. All other connections are made at solder terminals on the pc board. Table 2 identifies the terminals used for these connections. The view of the pc board at the rear of the manual identifies the solder terminals on the pcb module.

Power and control signals should be connected to the unit with #22 solid hookup wire. Be careful not to route the wiring close to the components on the left hand side or rear of the pc board, which contains sensitive rf circuits which could pick up noise or be detuned from the wiring.

**Be sure to solder wires only on the bottom of the board.** A short circuit can be created by soldering on the top.

### Antenna Connections.

The antenna connection should be made to the pc board with an RCA plug of the low-loss type made for rf. We sell good RCA plugs with cable clamp. See A5 plug on website.

If you want to extend the antenna connection to a panel connector, we recommend using a short length of RG-174/u coax with the plug and keep the pigtailed very short.

We do **not** recommend trying to use direct coax soldered to board or another type of connector. The method designed into the board results in lowest loss practical. When soldering the cable, keep the stripped ends as short as possible.

### Power Connections.

The receiver operates on +13.6 Vdc  $\pm$ 10%. Current drain is about 50 mA. A well filtered power supply should be used. There is a voltage regulator on the board.

Be sure that the power source does not carry high voltage or reverse polarity transients on the line, since semiconductors in the receiver can be damaged. The positive power supply lead should be connected to the receiver at terminal E3, and the negative power lead should be connected to the ground plane of the board through the mounting hardware or soldered to E6 ground terminal on the board. Be sure to observe polarity to avoid damage!

### Optional 12Vdc Power Adapter.

The A40 adapter is rated for 12Vdc at 200 mA load. It is a filtered dc power source but is not regulated. Since there is a voltage regulator on the receiver board, a regulated power supply is not necessary, as long as it is a well-filtered supply.

The adapter actually puts out close to 18Vdc with no load and drops to about 15-16Vdc with the load a receiver presents.

To install the adapter, clip the ends of the leads off and strip them about ¼ inch. The lead with the small grooves molded into it is positive, and the smoother lead is negative.

The stripped leads can be soldered to the + power input and ground terminals of the pc board. *Be sure to observe polarity to avoid damaging the receiver module. Because it is difficult to tell the ribbed lead from the smooth lead, double check before applying power to the radio to avoid damage.*

### Control Outputs.

The R123 has three output transistors used to turn on one or more relays. These are called Output A, Output B, and Output C, normally corresponding to 3, 5, and 7 clicks of the mic button. Each transistor can sink as much as 50mA at voltages up to +15Vdc. In other words, the transistors switch ground on and off and can be used to ground the (-) end of a relay input.

⚠ **CAUTION:** *Be careful not to exceed the voltage or current capabilities of the transistors. Also, be very careful about transients generated by inductive loads, such as relays. All mechanical relay coils must have a diode connected across the coil to absorb transients from inductive kickback, which can reach several hundred volts when the coil is switched off. See application diagrams, which follow, for examples of how to connect the diode, which basically must conduct any energy of reverse polarity; so the diode is connected*

backwards from regular polarity of the power source. Therefore, the diode does not conduct unless there is a reverse voltage. **NOTE THAT SOLID STATE RELAYS DO NOT HAVE A COIL; SO THEY DO NOT NEED A DIODE. SUCH RELAYS ARE PREFERRED BECAUSE THEY DO NOT PRESENT A DANGER TO THE RADIO.**

The relay should be mounted in an electrical cabinet for safety. If you use a solid state relay, it should be mounted on a metal surface for proper heatsinking. For instance, our A95 relay may be operated with a load up to 4Amp at room temperature with no heatsink. For operation at elevated temperatures or for load currents over 4 Amp (up to 10 Amp), the relay needs to be heat sunk to a large metal surface, and a good size electrical cabinet should provide ample surface for that.

To provide heatsinking for the relay, it must be mounted on a bare metal surface. If necessary, a large aluminum plate can be installed in the cabinet to provide bare metal for heatsinking. Before screwing the relay to the heatsink surface, spread a very thin layer of heatsink compound on the metal relay base to transfer the heat to the heatsink.

● **CAUTION:** *Installer is responsible to ensure that proper heatsinking is provided. Warranty does not cover damage to relay which might result from improper installation.*

To allow pilot control of runway lights (PCL), the three output transistors are turned on by clicking the microphone button in the aircraft, as explained later under Operation. Three clicks in five seconds turns on Output A, five clicks turns on Output B, and seven clicks turns on Output C. The outputs can be used to control relays to turn on the ac power for the lights. Think about how you want the lights to operate before wiring the outputs. There are ways to provide different options, depending on the wiring. The three outputs can be used to control relays for three levels of lighting. (More information in Operation section.)

Figure 2 shows two ways to turn on large ac loads with the receiver. The preferred method is to use a modern solid state relay which can be controlled with a small dc current and switch large ac loads. Solid state relays can be obtained from Hamtronics as an accessory. Figure 2A shows how to wire a solid state relay, with the negative side of the control input switched by the output of receiver.

The older method of switching large loads

Table 2. Connections.	
Function	Terminal
Ground	Mtg Screws & E6
+13.6 Vdc Power	E3
Speaker	E2
Relay Out A (3 clicks)	E7
Relay Out B (5 clicks)	E8
Relay Out C (7 clicks)	E9

(E1, E4, & E5 normally not used)

is to use a small dc relay to turn on a large ac power contactor. This method is shown in figure 2B. Make sure that the smaller relay can be operated with less than 50mA of current, and be sure to place a reverse polarity diode across the coil to prevent inductive kickback from damaging the receiver. This diode can be almost any type, including 1N4148, 1N914, 1N4001.

## OPERATION.

### General.

The R123 has a microcontroller which is responsible for watching the squelch to determine what is happening on the air. Green LED D5, on the left, indicates when a signal is detected. Red LED D6, on the right, is used to indicate when any one, two, or three of the outputs are turned on by the receiver.

### Squelch Setting.

The squelch control, which is the small trim pot on the left side of the board, sets the threshold at which signals will be detected. Green LED D5, on the left, indicates when a signal is detected. The proper way to set the squelch threshold is to turn the pot ccw until the LED comes on and then turn it cw just past the point where the LED turns off again. Of course, do this when no one is transmitting. If you have a speaker connected, you can also listen to determine when the squelch is open.

**There may be installations where this default setting is too sensitive. If you get false triggering of the relay, try setting the squelch control a little more clockwise.** Since aircraft normally have line of sight communications with the airport, most times a receiver does not need maximum sensitivity.

### Option Switch.

Ten position dip switch S1 is used to program the microcontroller for two functions. Switch section 1 provides selection of a timer option. Sections 2-10 set the channel frequency.

Switch 1 selects an option to allow changes to be made by the pilot after initially turning on lights. If this switch is off, the receiver accepts only the first valid command

until the timer expires, eg, 15 minutes. If this switch is on, the receiver will accept a new command while the timer is running, either another intensity or extending the current intensity.

Switch positions 2 through 10 are used to set the channel frequency. A detailed explanation appears later in the manual in alignment procedures.

### Pilot Control of Lighting.

If a pilot clicks his push-to-talk button three, five, or seven times within five seconds, runway lights can be activated with Outputs A, B, and C, respectively. Depending on wiring, this can turn on runway lights at up to 3 intensity levels.

The receiver is designed to meet FAA standards, which basically say the following:

The decoder must energize 1, 2, or 3 relays upon the receipt of a series (7 pulses maximum) of electrical pulses (microphone clicks) within a 5 second period, hold the relays energized for 15 minutes, and de-energize the relays after 15 minutes.

Further, a 5.0 second gate period must be started by the first pulse received. At the third pulse, the first relay must be energized. At the fifth pulse, the second relay must be energized. At the seventh pulse, the third relay must be energized.

If 2 or 3 relays are energized and a new series of pulses are received, at the third pulse, all relays except the first, must be de-energized and the timer reset for a full 15 minutes. At the fifth pulse, the second relay must be energized. At the seventh pulse, the third relay must be energized.

This option for allowing changes to be made after the initial setting is selected with dip switch #1, as previously explained.

When you install the system, carefully plan how you want the lights to respond to any possible condition. With the proper combination of programming and wiring the outputs to relays, you can make the lighting system operate smoothly and safely. Following are factors to be considered.

The three outputs can be used to control three different intensities of lights by turning

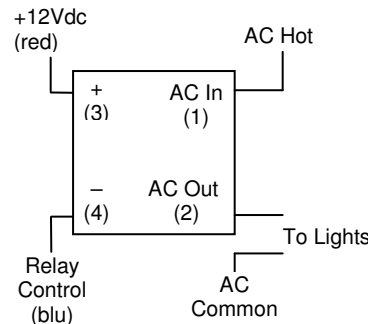

Figure 2A. Solid State Relay Wiring.

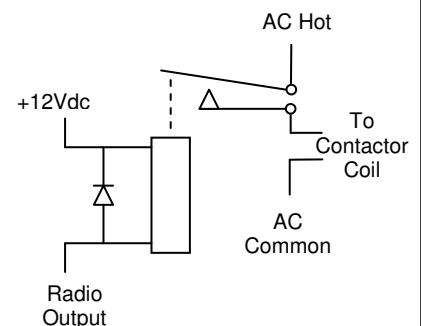

Figure 2B. Small Relay Switching Power Contactor.

on different electric circuits to the lights. More often, though, only a single intensity is used, especially with newer styles of lights, and any one of the three outputs can be used for the single relay to turn on those lights. Thus, by selecting which output you wire to the relay, you can require 3, 5, or 7 clicks to activate the lights.

The receiver has the option of allowing changes to the command after an initial command is executed. If the switch is on, subsequent commands will be carried out, otherwise, they will be ignored until the time delay is completed for turning off the lights. If you do not allow changes and someone, even unintentionally, sends a command, they cannot carry out another command for 15 minutes or whatever the time delay is set for.

Red LED (D6) on the front of the receiver will illuminate anytime a command is in effect, that is, whenever one of the outputs is activated. Note that multiple outputs can be turned on at once. Output A (and the red LED) always comes on when the first three clicks are received. Output B comes on if 5 or more clicks are received, and Output C comes on if 7 or more clicks are received within the 5 second window.

### If you have problems turning on lights.

A few users have commented that they have trouble turning on lights sometimes or that the lights turn off early. Here are a few things to consider.

The number of clicks is important. You must send exactly the correct number of clicks within 5 seconds. Requiring 5 or 7 clicks is a bit harder to send accurately than 3 clicks; so most airports use 3 clicks.

Dip switch position 1 may be turned on to permit changes to be made by the pilot after initially turning on lights. If this switch is off, the receiver accepts only the commands sent within the 5 second window beginning with the first click. After one or more outputs are turned on, no changes can be made for 15 minutes.

The receiver may also pick up signals a pilot is sending to a nearby airport if they use the same frequency you do. So always consider that a command might be coming from someone other than a pilot using your airport. It is good to use a unique channel frequency for your receiver. Most of our customers order receivers for 122.800 or 122.900MHz. So if you use one of these channels for your receiver, another nearby airport may also use that channel.

If you are picking up signals from pilots far away, it may be that your receiver is too sensitive. Because aircraft have line of sight to the airport, signals can be received over a great range. Your antenna may be too effective (if

you use a big antenna), or you may need to adjust the squelch sensitivity in the receiver to prevent weaker signals from activating the receiver. Refer to the section on Squelch Setting above.

## FREQUENCY SETTING.

The channel frequency is determined by frequency synthesizer circuits, which use the DIP switch in conjunction with programming in the microcontroller to set the frequency. The microcontroller reads the dip switch information and does mathematics, applying data to the synthesizer ic. Following is a discussion of how to set the dip switch to the desired channel frequency.

**NOTE:** *If the frequency is changed more than about  $\pm 1$  MHz, a complete alignment of the receiver should be performed, as described in later text. Optimum operation only occurs if the synthesizer is adjusted to match the frequency switch setting and all the tuned amplifier circuits are peaked for the desired frequency. It is anticipated that most customers will continue to use the alignment done at the factory for the frequency they specified. There is no reason to do anything unless you need to change frequencies. Be careful not to disturb the DIP switch if you don't need to change frequencies.*

To determine what channel frequency to use, the microcontroller adds the frequency information from the dip switch to the normal 120MHz "base" frequency (or alternate base frequency we use for receivers for frequencies very high or very low in the band, which are unusual).

Dip switch settings are binary, which means each switch section has a different weighting, twice as great as the next lower section. Sections have weights such as 25 kHz, 50 kHz, 100kHz, etc., all the way up to 12.775 MHz.

When done, you might want to record the switch settings in table 3 for future reference.

We make it easy by publishing a long table of possible settings on our website. Refer to the following link and be sure to type in the underscore characters...

[http://www.hamtronics.com/dipswitch\\_R123\\_R317.htm](http://www.hamtronics.com/dipswitch_R123_R317.htm)

The table online has two sections to it. The first set of listings is for a 120MHz base frequency, which most receivers use. Because the dip switch has a range of less than the full band, we program the micro with a different base frequency for those few receivers sold for use at the very low or very high end of the aircraft band. Those settings are shown in the second section online.

Look up the frequency, and it will give you all the binary switch settings.

For example, here are settings for two common frequencies, using 120MHz base. Note that the X in the first position represents

the option switch, not part of the frequency, as explained earlier.

122.800 MHz = X0011 10000

122.900 MHz = X0011 10100

## ALIGNMENT.

### General Information.

It is assumed that the Receiver was ordered for a particular frequency and aligned at the factory for that frequency. The following procedure is only necessary if you change frequencies by more than 1MHz. Most customers will never have to perform alignment.

Following are three alignment procedures. The first is alignment of the frequency synthesizer and receiver front end (rf amplifier and mixer). This must be done whenever the channel frequency is changed by more than 1 MHz. The R123 is a high performance receiver and is designed to be very selective. Therefore, retuning is necessary for optimum performance. The second procedure is alignment of the i-f stages, which normally is only necessary if some parts are replaced. The third procedure is trimming the TCXO (temperature compensated crystal oscillator) to exact frequency, which normally is never necessary.

### Equipment Needed.

Equipment needed for alignment is a sensitive dc voltmeter and a stable and accurate communications service monitor for the channel frequency.

The slug tuned coils in the receiver should be adjusted with the proper hex tuning tool to avoid cracking the powdered iron slugs. Variable capacitors and i-f transformers should be adjusted with a plastic tool having a small ceramic or metal bit. See our A1 Tuning Tool if you don't have one.

### Channel Frequency Alignment.

Alignment is needed whenever the frequency is changed by more than about 1 MHz. Alignment ensures that the frequency synthesizer is optimized at the center of the vco range and that all stages are tuned to resonance.

a. Set dip switches for desired frequency.

b. Connect dc voltmeter to Osc Tune test point TP1 (pad on top of pcb). Adjust vco coil L1 for +2Vdc. (Although the vco will operate over a wide range of tuning voltages from about 1V to 5V, operation is optimum if the vco is adjusted to 2V.)

c. Connect dc voltmeter to buffer TP2 (pad on top of pcb). Adjust buffer coil L2 for a peak.

d. Connect dc voltmeter to RF Tune test point TP4 (pad on top of pcb), or alternately, use a SINAD meter.

e. Connect service monitor signal generator output to J1 using a coax cable with RCA plug. Adjust signal generator to exact



properly. Check the dc voltages, and look for noise in the 10 kHz region, which should be present at U4-pin 11 with no input signal. (Between pins 10 and 11 of U4 is an op-amp active filter tuned to 10 kHz.)

### RF Signal Tracing.

If the receiver is completely dead, try a 10.700 MHz signal applied to TP-3 using coax test lead. Set level just high enough for full quieting. At 1  $\mu$ V, you should notice some quieting, but you need something near full quieting for the test.

You can also connect the 10.700 MHz test lead through a blocking capacitor to various sections of the crystal filter to see if there is a large loss of signal across one of the filter sections. Also, check the 10.245 MHz oscillator with a scope or by listening with an hf receiver or service monitor.

A signal generator on the channel frequency can be injected at various points in the front end. If the mixer is more sensitive than the RF amplifier, the RF stage is suspect. Check the dc voltages looking for a damaged fet, which can occur due to transients or reverse polarity on the dc power line. Also, it is possible to have the input gate (gate 1) of the RF amplifier fet damaged by high static charges or high levels of RF on the antenna line, with no apparent change in dc voltages, since the input gate is normally at dc ground.

### Synthesizer Circuits.

Following is a checklist of things to look for if the synthesizer is suspected of not performing properly.

- Check the output frequency of the vco buffer with a frequency counter.
- Check tuning voltage at TP1. It should be about +2.0Vdc. Actual range over which the unit will operate is about +0.5Vdc to about +4.5Vdc. However, for optimum results, the vco should be tuned to allow operation at about +2.0Vdc center voltage.
- Check the operating voltage and bias on the vco and buffer.
- Check the TCXO at pin 1 of the synthesizer ic. A scope should show strong signal (1.5 Vp-p) at 10.240 MHz.
- The data, clock, and latch enable lines between the microcontroller and synthesizer ic's should show very brief and very fast activity, sending data to the synthesizer ic. Because this happens very fast, it can be difficult to see on a scope. Use 1mSec/div, 5Vdc/div, and normal trigger.

### Microphonics, Hum, and Noise.

The vco and loop filter are very sensitive to hum and noise pickup from magnetic and

electrical sources. Some designs use a shielded compartment for vco's. We assume the whole board will be installed in a shielded enclosure; so we elected to keep the size small by not using a separate shield on the vco. However, this means that you must use care to keep wiring away from the vco circuit. Having the board in a metal enclosure will shield these sensitive circuits from florescent lights and other strong sources of noise.

Because the frequency of a synthesizer basically results from a free running L-C oscillator, the tank circuit, especially L1, is very sensitive to microphonics from mechanical noise coupled to the coil. You should minimize any sources of vibration which might be coupled to the receiver, such as motors.

Excessive noise on the dc power supply which operates the receiver can cause noise to modulate the synthesizer output. Various regulators and filters in the receiver are designed to minimize sensitivity to wiring noise.

To varying degrees, whine from the 5kHz reference frequency may be heard on the signal under various circumstances. If the tuning voltage required to tune the vco on frequency is very high or low, near one extreme, the whine may be heard. This can also happen even when the tuning voltage is properly near the 2.0Vdc center if there is dc loading on the loop filter. Any current loading, no matter how small, on the loop filter causes the phase detector to pump harder to maintain the tuning voltage. The result is whine on the signal. Such loading can be caused by connecting a voltmeter to TP1 for testing, and it can also be caused by moisture on the loop filter components.

### Typical DC Voltages.

Tables 4-6 give dc levels measured with a sensitive dc voltmeter on a sample unit with 13.6 Vdc B+ applied. All voltages may vary considerably without necessarily indicating trouble. The charts should be used with a logical troubleshooting plan. All voltages are positive with respect to ground except as indicated.

Use caution when measuring voltages on surface mount ics. The pins are close together, and it is easy to short pins together and damage the ic. Try to connect meter to a nearby component connected to the pin under question.

### Typical Audio Levels.

Table 7 gives rough measurements of audio levels. Measurements were taken using an oscilloscope, with no input signal, just

white noise so conditions can be reproduced easily.

**Table 4. Typical Test Point Voltages**

TP1	Tuning V.	Normally set at 2V
TP2	Buffer	approx. 0.3 – 0.6V
TP3	Test Input	(No reading)
TP4	Noise det.	With SQUELCH control fully ccw, varies from -0.3 Vdc with no to +0.9 Vdc full quieting.
E4	DISC	Varies with frequency of input signal. Voltage at this point normally is adjusted for +2Vdc with a signal exactly on frequency. Can vary a little without being a problem.

**Table 5. Typical Xstr DC Voltages**

Xstr	Stage	E(S)	B(G1)	C(D)	G2
Q1	vco	0.9	1.6	3.8	-
Q2	buffer	0	0.7	2.4	-
Q3	dc filter	4.1	4.8	5	-
Q4	RF ampl	0	0	4.6	2.3
Q5	Mixer	0	0	4.9	0
Q6	sq. open	0	0	5	-
	sq. closed	0	0.65	0.14	-

**Table 6. Typical IC DC Voltages**

U2-1	2.4	U4-1	5
U2-2	2.4	U4-2	4.4
U2-3&4	5	U4-3	4.8
U2-5	0 – 5V (~2V tuned)	U4-4	5
		U4-5	3.8
U2-7	5	U4-6	3.8
U2-8	1.6	U4-7	3.8
U2-9	0	U4-8	5
U2-10	0	U4-9	2 (aligned)
U2-11	0	U4-10	0.8
		U4-11	2
U5-1	1.4	U4-12	0.6 (with squelch just closed)
U5-3	0.01	U4-13	0 (sq open)
U5-5	6	U4-14	0
U5-6	13.6	U4-15	0
U5-7	7	U4-16	1.8
U5-8	1.4		

**Table 7. Typical Audio Voltages**

Audio Test Point	Normal Level
U4-9 (Discriminator)	3V p-p audio
E4 (Disc Output)	2V p-p audio
E1 (Repeater Output)	1V p-p audio
U4-11 (noise ampl)	3V p-p noise
CW lug of VOL cont.	400mV p-p audio
U5-3 (af ampl input)	0 to 200mV p-p
U5-5 or E2 (speaker ampl output)	0 to 7V p-p audio

## PARTS LIST FOR R123 RECEIVER.

Note: Resistors and capacitors are 0805 or 0603 smt type unless noted otherwise.

Values shown are for 120 – 130 MHz range. Factory changes some values for frequencies beyond this range.

⚠ Caution: IC's are static sensitive. Use appropriate handling precautions to avoid damage.

\* Polarity for LED's: long lead is anode, same as electrolytic caps.

\*\* Polarity for varicap diode D1: bar end is cathode, opposite end (anode) goes on pad next to grounding via.

Ref Desig	Value (marking)
C1	0.1µf
C2	100pf
C3	0.1µf
C4	100µf electrolytic
C5	0.15µf mylar
C6	.01µf
C7	.001uf
C8-C9	100µf electrolytic
C10	0.1µf
C11	390pf
C12	10pf
C13	100µf electrolytic
C14	390pf
C15	18pf
C16	68pf
C17	7pf
C18	390pf
C19	39pf
C20	62pf
C21	3pf
C22	39pf
C23	100pf
C24-C25	390pf
C26	33pf
C27	0.2pf
C28	33pf

C29	0.2pf
C30	27pf
C31	4pf
C32	390pf
C33	27pf
C34	82pf
C35	.033µf
C36	7pf
C37	4pf
C38	7pf
C39	.001uf
C40	1µf electrolytic
C41	0.1µf
C42-C43	.001µf
C44-C45	.033µf
C46	0.1µf
C47	4.7µf electrolytic
C48	0.1µf
C49	100µf electrolytic
C50	68pf
C51	220pf
C52-C54	0.1µf
C55-C56	100µf electrolytic
D1	BB132 varactor diode **
D2	MMBT5179 (used as diode)
D3-D4	MMBT3904 (used as diode)
D5	Green LED *
D6	Red LED *
FL1-FL4	10.7MHz crystal filter (matched set of 4)
FL5	LT455DW ceramic filter
J1	RCA Jack
J2	6 pin header
L1	2½ t. slug tuned (red)
L2	0.33µH RF choke (red-sil-orn-orn)
L3-L8	2½ t. slug tuned (red)
Q1-Q2	MMBT5179
Q3	MMBT3904
Q4-Q5	BF998 MOS FET
Q6-Q11	MMBT3904
R1	180Ω
R2	27Ω
R3	10K
R4	47K
R5	27Ω
R6	1K

R7	27Ω
R8-R10	10K
R11	180Ω
R12	47Ω
R13	10K
R14	3.9K
R15	470Ω
R16	1meg
R17	1K
R18	10Ω
R19-R20	100K
R21	180Ω
R22	47K
R23	27Ω
R24	47K
R25	100K trim pot
R26	47K
R27	100K
R28	1K
R29	2meg
R30	47K
R31	510K
R32	4.7K
R33	680Ω
R34	1K
R35	22K
R36	100K
R37	100K trim pot
R38	47K
R39	10Ω
R40	47K
R41	10K
R42	100Ω
R43	470Ω
R44-R46	3.3K
S1	10 pos. dip switch
T1-T2	10.7MHz IF xfmr (T1005)
T3	455kHz IF xfmr (T1003)
U1	⚠ MC9S08PA4VWJ µP
U2	⚠ LMX1501A PLL
U3	⚠ 10.240 MHz TCXO
U4	MC3361BP-S16 IF ampl
U5	LM386N-1 AF output
U6	78L05ACD regulator
Y1	10.245 MHz crystal

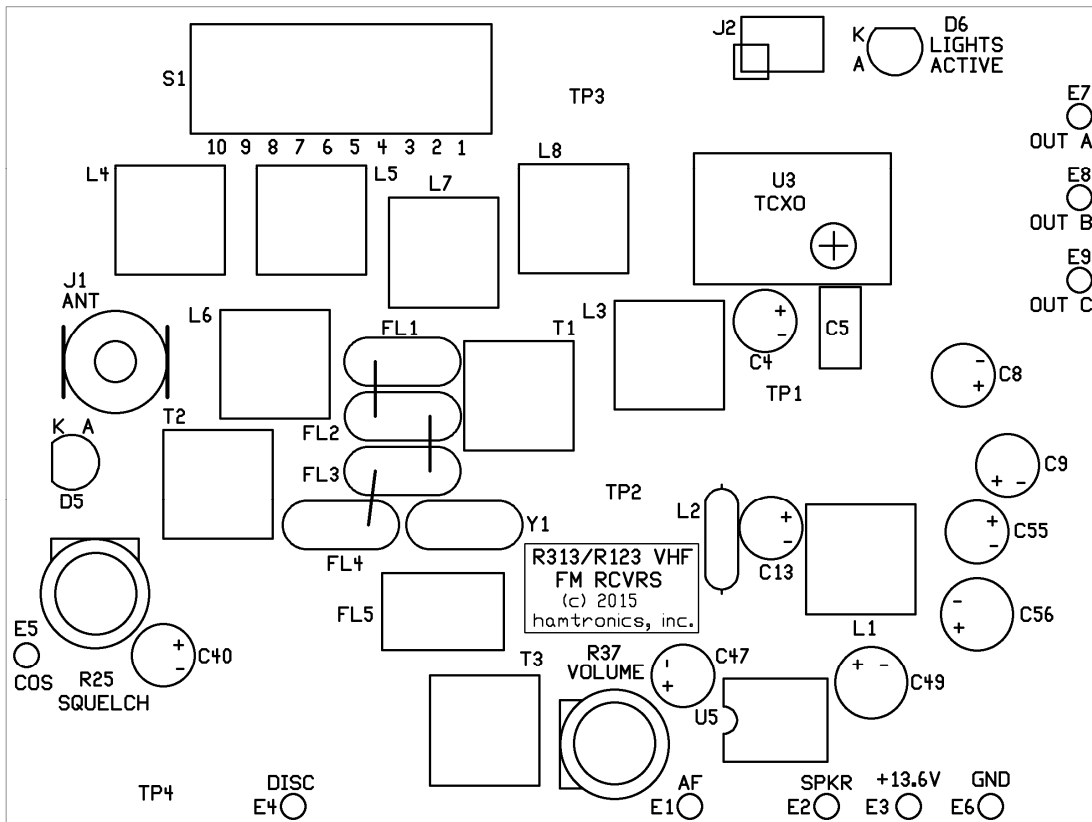
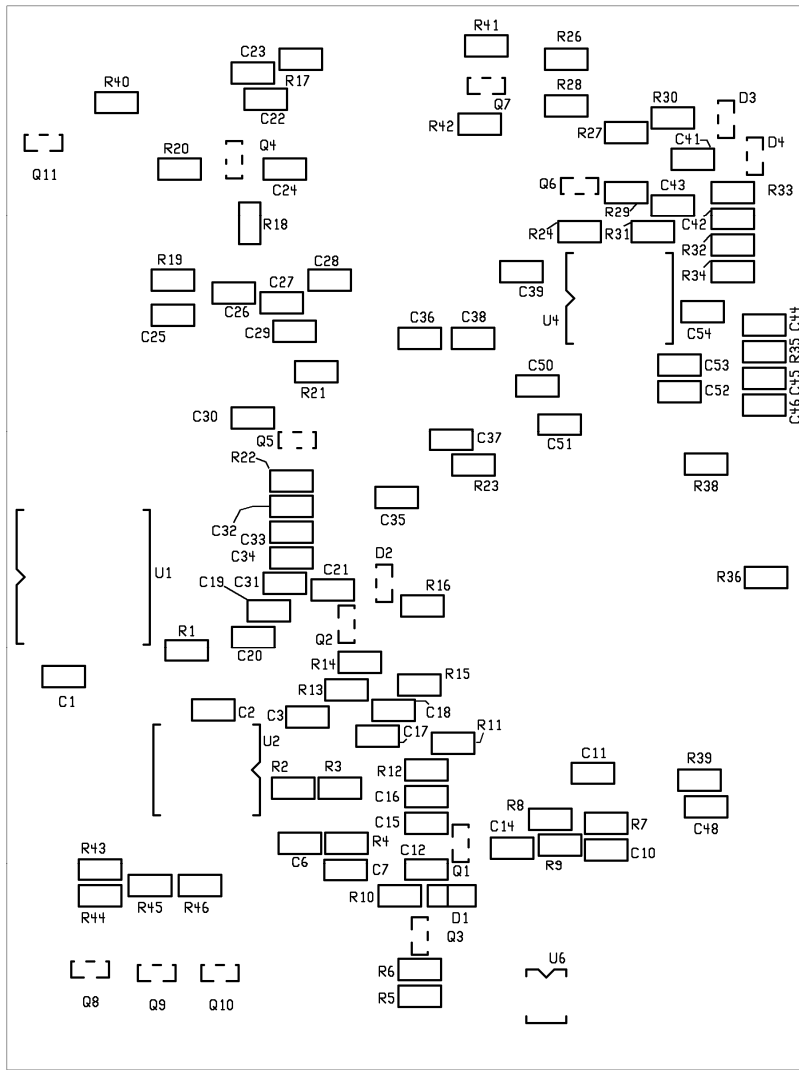

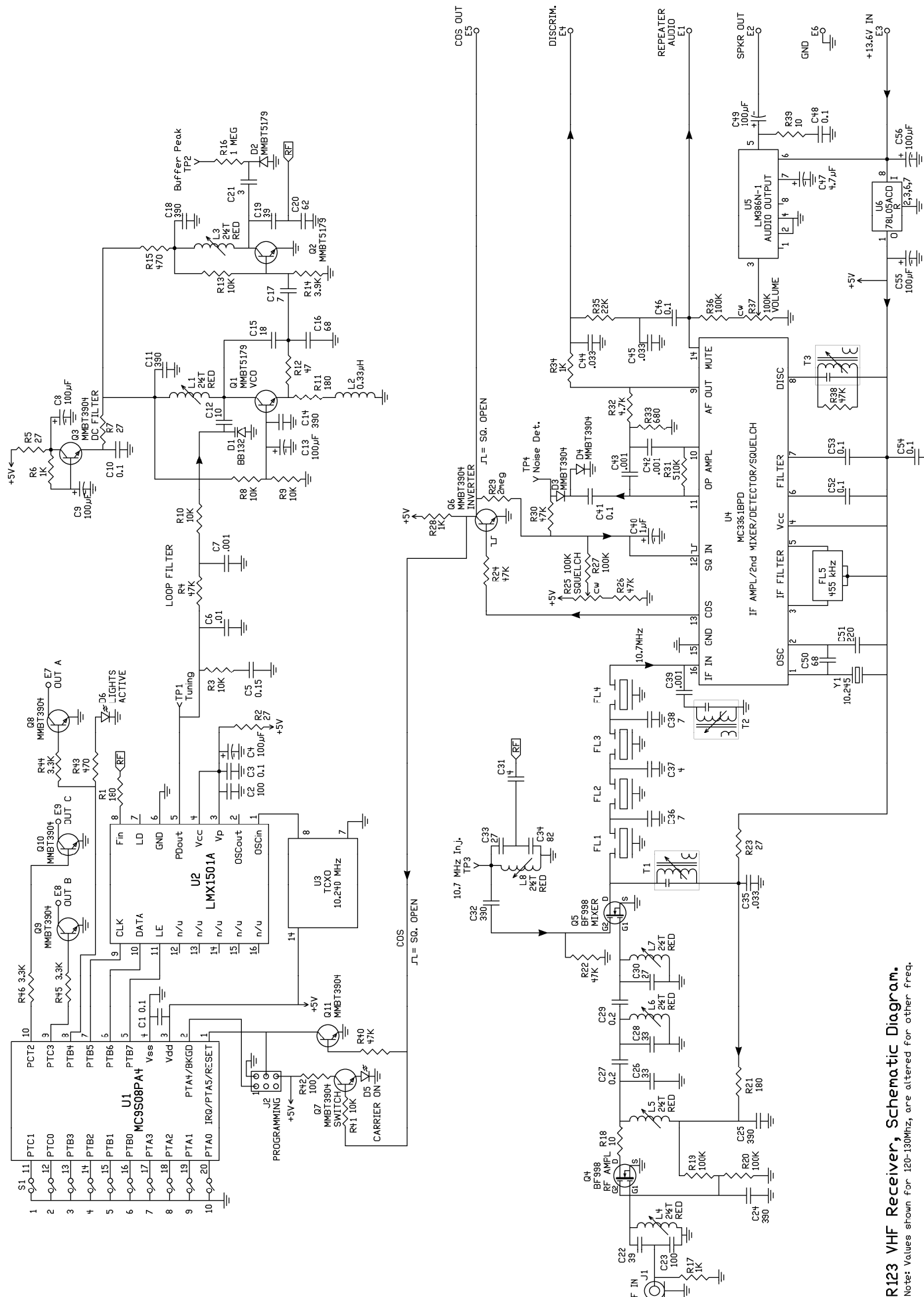

**R123 VHF Receiver, Schematic Diagram.**  
 Note: Values shown for 120-130MHz, are altered for other freq.