

# HAMTRONICS® R302 VHF FM RECEIVER: INSTALLATION, OPERATION, & MAINTENANCE

## GENERAL INFORMATION.

The R302 is the latest in a series of popular receivers for demanding applications which require exceptional sensitivity and selectivity. It is especially suited for repeaters, audio and data links, and remote control. The R302 was designed to provide instant setup without lengthy waits to obtain channel crystals. It is a single-channel vhf fm receiver available in several models for reception in the 144 MHz ham band, the 148-174 MHz commercial band, or 216-226 MHz.

The R302 is our 8th generation vhf fm receiver, and it packs in features you've told us are important to you during our 40 years of designing receivers. It's up to the difficult jobs you've told us you have.

The R302 retains all of the popular features Hamtronics® receivers have been noted for. It uses triple-tuned circuits in the front end and excellent crystal and ceramic filters in the i-f with steep skirts for close channel spacing or repeater operation. The i-f selectivity, for instance, is down over 100dB at  $\pm 12$  kHz away from the carrier, which is 40-50 dB better than most transceivers. Low noise fet's in the front end provide good overload resistance and excellent sensitivity.

The R302 is designed for narrow-band fm with  $\pm 5$  kHz deviation. The audio output will drive any load as low as  $8\Omega$  with up to 1 Watt continuous output. The receiver may be used with either voice or fsk data up to 9600 baud using an external data interface unit. An accessory TD-5 CTCSS Decoder unit is available for subaudible tone control.

The R302 features a positive-acting, wide-range squelch circuit and additional output terminals for low-level squelched audio and discriminator audio as well as COS.

There are several models, which have minor variations in parts and microcontroller programming, to provide coverage as shown in table 1. Channel frequency is controlled by a synthesizer with DIP switch channel setting.

The TCXO (temperature controlled xtal oscillator) provides a temperature stability of  $\pm 2$ ppm over a temperature range of  $-30^{\circ}\text{C}$  to  $+60^{\circ}\text{C}$ .

## INSTALLATION.

### Mounting.

Some form of support should be provided under the pc board, generally mounting the board with spacers to a chassis. 3/8-inch holes should be provided in a front panel for the bushings of the SQUELCH and VOLUME controls. After sliding bushings through panel, washers and nuts can be installed on the outside of the panel. Be sure to provide support for the board; do not rely on the controls to support the board, since that could cause a break in the pcb solder connections.

The receiver board relies on the mounting hardware to provide the dc and speaker ground connections to the ground plane on the board; so metal standoffs and screws should be used for mounting.

### Electrical Connections.

Power and input audio or data signals should be connected to the solder pads on the pc board with #22 solid hookup wire, which can be attached to a connector or feedthrough capacitors used on the cabinet in which it is installed. Be very careful not to route the wiring near the components on the left hand side of the board, which contains sensitive loop filter and vco circuits which could pick up noise from the wiring.

### Power Connections.

The receiver operates on +13.6 Vdc at about 200 mA peak with full audio. Current drain with no audio is only about 45 mA. A well regulated power supply should be used.

Be sure that the power source does not carry high voltage or reverse polarity transients on the line, since semiconductors in the receiver can be damaged. The positive power supply lead should be connected to the receiver at terminal E3, and the negative power lead should be connected to the ground plane of the board through the mounting hardware or the shield of the coaxial cable. Be sure to observe polarity!

### Speaker.

An 8-ohm loudspeaker should be connected to E2 with ground return through the mounting hardware. Use of lower impedance speaker or short-

ing of speaker terminal can result in ic damage. The receiver can also drive higher impedances, such as the 1K to 20K input impedances of repeater controller boards. There is no need to load down the output to 8 ohms.

☛ *Note that the audio output ic is designed to be heatsunk to the pc board through the many ground pins on the ic. When running moderately low audio levels as most applications require, it is no problem to use an ic socket; so we have provided one for your convenience. If you will be running high audio levels, check to see if the ic is getting hot. If so, you should remove the ic socket, and solder the LM-386 ic directly to the board for better heatsinking.*

### Antenna Connections.

The antenna connection should be made to the receiver with an RCA plug of the low-loss type made for rf. We have them available if you need one.

If you want to extend the antenna connection to a panel connector, we recommend using a short length of RG-174/u coax and a good RCA plug with cable clamp (*see catalog*). When soldering the cable, keep the stripped ends as short as possible.

We do not recommend trying to use direct coax soldered to board or another type of connector. The method designed into the board results in lowest loss practical.

☛ *We recommend you always use antennas with a matching network which provides a dc ground on the driven element. This reduces chances of static buildup damaging the input stage of the receiver as well as providing safety for the building and other*

**Table 1. Quick Specification Reference**

<b>Model R302-1</b>	138.000 - 148.235 MHz
<b>Model R302-2</b>	144.000 - 154.235 MHz
<b>Model R302-3</b>	154.200 - 164.435 MHz
<b>Model R302-4</b>	164.400 - 174.635 MHz
<b>Model R302-5</b>	216.000 - 226.235 MHz
<b>Model R302-6</b>	220.000 - 230.235 MHz
<b>Sensitivity</b> (12dB SINAD):	0.15 to 0.2 $\mu$ V
<b>Squelch Sensitivity:</b>	0.2 $\mu$ V
<b>Adjacent Channel Selectivity:</b>	$\pm 12$ kHz at -100dB!
<b>Image Rejection:</b>	60-70dB
<b>Modulation Acceptance:</b>	$\pm 7.5$ kHz
<b>Frequency Stability:</b>	$\pm 2$ ppm $-30^{\circ}\text{C}$ to $+60^{\circ}\text{C}$
<b>Audio Output:</b>	up to 1 Watt (8 ohms).
<b>Operating Power:</b>	+13.6Vdc (+10 to +15Vdc) at 45-200 mA, depending on audio level.
<b>Size:</b>	4 in. W x 2-7/8 in. D (plus pot. shafts)

equipment.

## OPTIONS.

### Repeater Use.

E5 provides a COS (carrier operated switch) output which may be connected to a COR module to turn a transmitter on and off. The output level is about 8V unsquelched and 0V squelched. There is a resistor in series with the output to limit current. Therefore, the voltage that appears at the COR board will depend on the load resistance at the input of that board. For best results, be sure that the input resistance of the COR board is at least 47K. If the input resistance is too low, no damage to the receiver will occur; but the squelch circuit hysteresis will be affected.

If your repeater controller uses discriminator audio, rather than the speaker output, filtered discriminator audio is available at E4. The level is about 2V p-p. *Note that discriminator audio is not de-emphasized or squelched.* If you need audio which is squelched, take it from Repeater Audio terminal E1.

If your controller uses low level audio and has a high input impedance (20K or higher), squelched audio can be obtained from E1 independent of the VOLUME control.

### Discriminator Meter.

If you wish to use a discriminator meter and you are handy in designing with op-amps, you can run a sample of the dc voltage at *DISCRIMINATOR* output terminal E4 to one input of an op-amp and tie the other input to a voltage divider pot set to provide a reference voltage of about +3.3Vdc.

### S-Meter.

There is no s-meter function, as such, available in i-f amplifier ic's made for professional receivers; however, a signal strength indication is available at test point TP-4. This voltage is a function of the noise level detected in the squelch circuit. It also varies with SQUELCH control setting. With the SQUELCH set to where the squelch just closes, the dc voltage at TP-4 is about -0.5V with no signal and +1V with full quieting signal. You can tap off this test point with a high-impedance circuit, such as an op-amp, to drive a meter or a computerized repeater controller.

### Subaudible Tone Decoder.

To use our TD-5 Subaudible Tone Decoder or a similar module, connect its audio input to *DISCRIMINATOR*

terminal E4. If you want to use it to mute the audio (instead of inhibiting a repeater transmitter as is normally done), connect the mute output of the TD-5 to E1 on the receiver.

## ADJUSTMENTS.

### Frequency Netting.

All crystals age a little over a long period of time; so it is customary to tweak any receiver back onto the precise channel frequency once a year during routine maintenance. Because modern solid state equipment doesn't require much routine maintenance, many receivers don't get their oscillators tweaked as a matter of routine any more, but they should.

The adjustment should be done using an accurate service monitor or frequency counter. Of course, make sure the test equipment is exactly on frequency first by checking it against WWV or another frequency standard.

The channel frequency is trimmed precisely on frequency with a small variable capacitor, which is accessible through a hole in the top of the shield can on the TCXO. The proper tool is a plastic wand with a small metal bit in the end.

To perform this adjustment, it is first necessary to verify that the discriminator is properly adjusted. Do this by connecting a dc voltmeter to E4. Connect a signal generator set for 10.700 MHz to TP3, and set the level for a relatively strong signal so there is very little white noise. Adjust discriminator coil T2 for 3.3Vdc. Then, reconnect the signal generator to antenna connector J1, and set it for the precise channel frequency. You can also use a strong signal on the air if you are sure it is right on frequency. Adjust the TCXO capacitor for 3.3Vdc (to match the voltage obtained with the 10.700 MHz signal).

### Setting Channel Frequency.

The channel frequency is determined by frequency synthesizer circuits, which use a dip switch in conjunction with programming in a microcontroller to set the channel. The microcontroller reads the dip switch information and does mathematics, applying serial data to the synthesizer ic whenever power is applied. Following is a discussion of how to set the dip switch to the desired channel frequency.

☞ **NOTE:** *If the frequency is changed more than about 1 MHz, a complete alignment of the receiver should be performed, as described in*

*later text. Optimum operation only occurs if the synthesizer is adjusted to match the frequency switch setting and all the tuned amplifier circuits are peaked for the desired frequency.*

To determine what channel frequency to use, the microcontroller adds the frequency information from the dip switch to a "base" frequency stored in eeprom used for microcontroller programming. Each model of the R302 Receiver has a particular base frequency. For example, the R302-2 has a base frequency of 144.000 MHz, as shown in Table 1.

Dip switch settings are binary, which means each switch section has a different weighting, twice as great as the next lower section. Sections have weights such as 5 kHz, 10 kHz, etc., all the way up to 2.56 MHz. (*See Table 2 or the schematic diagram for switch values.*)

The system sounds cumbersome, but it really is fairly simple, and you don't need to do this frequently. A piece of paper or a small calculator is handy to aid in determining which sections of the switch to turn on. When done, you might want to record the switch settings in table 3 for future reference.

Begin by subtracting the base frequency, e.g., 144.000, from the desired frequency to determine the total value of all the switch sections required to be turned on.

If the difference is more than 5.120MHz, turn on dip switch section 1, and subtract 5.120 from the starting frequency. Otherwise, turn off section 1.

Likewise, look at the remainder frequency and see if you can subtract 2.560 from it. If so, turn on dip switch section 2, and subtract 2.560 from to get a new remainder. Otherwise, turn off section 2.

Do the same for each of the other sections, from highest to lowest weighting, in sequence. Each time you consider the remainder, turn on the switch section with the highest weighting which will fit within the remainder without exceeding it. Each time it is found necessary to turn on a switch section, subtract the value of that section from the remainder to get the new remainder.

**As an example,** let us consider how to set the Receiver for 146.94 MHz. The following discussion is broken down into steps so you can visualize the process easier.

a. 146.940 - 144.000 base freq. = 2.940 MHz remainder. Turn on

switch #2, which represents the largest increment to fit remainder.

b. 2.940 - 2.560 value of switch #2 = 0.380 MHz. Turn on #5, which is 0.320 MHz, the largest increment to fit the remainder.

c.  $0.380 - 0.320 = .060$  MHz remainder. Turn on switch #8 and switch #9, which have values of .040 and .020, respectively, which adds up to the remainder of .060 MHz. *Note that when the remainder gets down into the double digit range, it is very easy to visualize turning on multiple switch sections to satisfy the entire remainder, such as we just did.*

d. When we finished, we had turned on switch sections 2, 5, 8, and 9.

**Note:** Dip switch information is read by the synthesizer only when power is first applied. If switch settings are changed, turn the power off and on again.

### Shortcut ---

If you have access to the internet, our website has a long table of numbers which gives the equivalent binary number settings for every possible frequency. We couldn't print it here because it takes many printed pages of space. Surf to our website at [www.hamtronics.com](http://www.hamtronics.com) and look for Dip Switch Freq Programming for R302 under Reference Info near the bottom of the Table of Contents. Look up the frequency, and it will give you all the binary switch settings.

### Tricks ---

Although most users will set up the Receiver on a single frequency and perhaps never change it, there may be applications where you want to change between two or more nearby frequencies. In such cases, it is helpful to note the switch settings for the lowest of the frequencies and simply which of the lower value switch sections to turn on to raise the frequency to the higher channels. E.g., to change from 146.790 to 146.820, note that you need to turn on switch sections to add 30 kHz to the setting for

146.790. It is not necessary to recalculate the whole range of settings.

## ALIGNMENT.

### General Procedure.

A complete alignment is needed whenever the frequency is changed by more than about 1 MHz. Alignment ensures that the frequency synthesizer is optimized at the center of the vco range and that all stages are tuned to resonance.

Equipment needed for alignment is a sensitive dc voltmeter, a stable and accurate signal generator for the channel frequency, and a regulated 13.6Vdc power supply with a 0-200 mA meter internally or externally connected in the supply line.

The slug tuned coils in the Receiver should be adjusted with the proper .062" square tuning tool to avoid cracking the powdered iron slugs. Variable capacitors should be adjusted with a plastic tool having a small metal bit. (See A28 and A2 tools in catalog.) All variable capacitors should be set to the center of their range. Turn them 90° if they have not previously been aligned (except on the optional TCXO).

**Note:** Meter indications used as references are typical but may vary widely due to many factors not related to performance, such as type of meter and circuit tolerances. Typical test point indications are for the 144 MHz band unit and may differ for other bands.

a. Set the SQUELCH pot fully counterclockwise and the VOLUME pot just a little clockwise.

b. Connect speaker and +13.6 Vdc. You should hear white noise.

c. Set dip switches for desired frequency.

d. Connect voltmeter to TP1. Adjust vco coil L1 for +2.0Vdc. (Although the vco will operate over a wide range of tuning voltages from about 0.5V to 4.5V, operation is optimum if the vco is adjusted to 2.0V.)

e. Connect voltmeter to TP2. Adjust buffer coil L3 for a peak, typically about +0.35V.

f. Connect stable signal generator to TP-3. Set generator to exactly 10.7000 MHz. Use a frequency counter or synthesized signal generator. Set level just high enough for full quieting. At 1 uV, you should notice some quieting, but you need something near full quieting for the test (about 20µV).

g. Connect dc voltmeter to Discriminator terminal E4. Adjust dis-

criminator transformer T2 for +3.3Vdc.

**Note:** Be careful not to turn the slug tight against either the top or bottom because the winding of the transformer can be broken. The tuning response is an S-curve; so if you turn the slug several turns, you may think you are going in the proper direction even though you are tuning further away from center frequency.

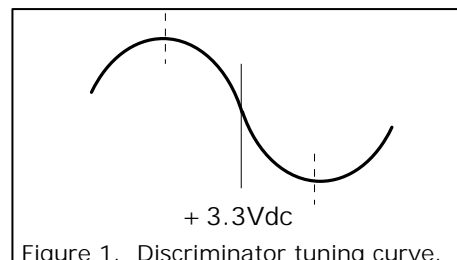

Figure 1. Discriminator tuning curve.

h. Connect signal generator to J1 using a coax cable with RCA plug. Adjust signal generator to exact channel frequency, and turn output level up fairly high (about 1000µV). Adjust frequency trimmer in TCXO to net the crystal to channel frequency, indicated by +3.3Vdc at E4.

**Note:** There are two methods of adjusting the mixer and front end. One is to use a voltmeter with test point TP-4. The voltage at this point is proportional to the amount of noise detected in the squelch circuit; so it gives an indication of the quieting of the receiver. With SQUELCH control fully ccw, the dc voltage at TP-4 varies from -0.5 Vdc with no signal (full noise) to +1 Vdc with full quieting signal.

The other method is to use a regular professional SINAD meter and a tone modulated signal.

In either case, a weak to moderate signal is required to observe any change in noise. If the signal is too strong, there will be no change in the reading as tuning progresses; so keep the signal generator turned down as receiver sensitivity increases during tuning.

If you use TP-4 with a voltmeter, the signal can be modulated or unmodulated. If you use a SINAD meter, the standard method is a 1000 Hz tone with 3 kHz deviation.

Table 2. Frequency Settings

Device	Frequency Weight
Switch #1	5.120 MHz
Switch #2	2.560 MHz
Switch #3	1.280 MHz
Switch #4	640 kHz
Switch #5	320 kHz
Switch #6	160 kHz
Switch #7	80 kHz
Switch #8	40 kHz
Switch #9	20 kHz
Switch #10	10 kHz
Switch #11	5 kHz

Table 3. My Switch Settings

Frequency: _____	_____ MHz									
Switch Sections Turned On: (circle)										
1	2	3	4	5	6	7	8	9	10	11

i. Connect fet dc voltmeter to TP4. Set signal generator for relatively weak signal, one which shows some change in the dc voltage indication at TP4. Alternately peak RF amplifier and mixer coils L4-L8 until no further improvement can be made.

When properly tuned, sensitivity should be about 0.15 to 0.2 $\mu$ V for 12 dB SINAD.

• Crystal filter trimmer coils T1 and T3 normally should not be adjusted. They are set at the factory. The purpose of the adjustment is to provide proper loading for the crystal filter, and if misadjusted, ripple in the filter response will result in a little distortion of the detected audio. If it becomes necessary to adjust T1 and T3, tune the signal generator accurately on frequency with about 4.5kHz fm deviation using a 1000 Hz tone. In order of preference, use either a SINAD meter, an oscilloscope, or just your ears, and fine tune T1 and T3 for minimum distortion of the detected audio.

## THEORY OF OPERATION.

The R302 is a frequency synthesized vhf fm Receiver. Refer to the schematic diagram for the following discussion.

Low noise dual-gate mos fet's are used for the RF amplifier and mixer stages. The output of mixer Q5 passes through an 8-pole crystal filter to get exceptional adjacent channel selectivity.

U4 provides IF amplification, a 2<sup>nd</sup> mixer to convert to 455 kHz, a discriminator, noise amplifier, and squelch. Ceramic filter FL5 provides additional selectivity at 455 kHz. The noise amplifier is an op amp active filter peaked at 10 kHz. It detects noise at frequencies normally far above the voice band. Its output at pin 11 is rectified and combined with a dc voltage from the SQUELCH control to turn a squelch transistor on and off inside the ic, which grounds the audio path when only noise is present. Inverter Q6 provides a dc output for use as a COS signal to repeater controllers.

The injection frequency for the first mixer is generated by vco (voltage controlled oscillator) Q1. The injection frequency is 10.700 MHz below the receive channel frequency. The output of the vco is buffered by Q2 to minimize effects of loading and voltage variations of following stages from modulating the carrier frequency. The buffer output is applied through a

double tuned circuit to gate 2 of mixer Q5.

The frequency of the vco stage is controlled by phase locked loop synthesizer U2. A sample of the vco output is applied through the buffer stage and R1 to a prescaler in U2. The prescaler and other dividers in the synthesizer divide the sample down to 5kHz.

A reference frequency of 10.240 MHz is generated by a TCXO (temperature compensated crystal oscillator). The reference is divided down to 5 kHz.

The two 5kHz signals are compared to determine what error exists between them. The result is a varying dc tuning voltage used to phase lock the vco precisely onto the desired channel frequency.

The tuning voltage is applied to carrier tune varactor diode D1, which varies its capacitance to tune the tank circuit formed by L1/C20/C21. C16 limits the tuning range of D1. The tuning voltage is applied to D1 through a third order low pass loop filter, which removes the 5kHz reference frequency from the tuning voltage to avoid whine.

In order for the synthesizer to lock, the vco must be tuned to allow it to generate the proper frequency within the range of voltages the phase detector in the synthesizer can generate, roughly 0.5Vdc to 4.5Vdc.

Serial data to indicate the desired channel frequency and other operational characteristics of the synthesizer are applied to synthesizer U2 by microcontroller U1. Everything the synthesizer needs to know about the band, division schemes, reference frequency, and oscillator options is generated by the controller. Information about the base frequency of the band the receiver is to operate on and the channel within that band is calculated in the controller based on information programmed in the eeprom on the controller and on channel settings done on dip switch S1. Whenever the microcontroller boots at power up, the microcontroller sends several bytes of serial data to the synthesizer, using the data, clock, and /enable lines running between the two ic's.

+13.6Vdc power for the Receiver is applied at E1. Audio output amplifier U5 is powered directly by the +13.6Vdc. All the other stages are powered through voltage regulators for stability and to eliminate noise. U6 is an 8Vdc regulator to power detector U4, RF amplifier Q4, mixer Q5,

and the vco and buffer. Additional filtering for the vco and buffer stages is provided by capacitance amplifier Q3, which uses the characteristics of an emitter follower to provide a very stiff supply, eliminating any possible noise on the power supply line. Regulator U7 provides a +5Vdc supply for the frequency synthesizer and microcontroller, which are both low current CMOS devices.

## TROUBLESHOOTING.

### General.

The usual troubleshooting techniques of checking dc voltages and signal tracing with an RF voltmeter probe and oscilloscope will work well in troubleshooting the R302. DC voltage charts and a list of typical audio levels are given to act as a guide to troubleshooting. Although voltages may vary widely from set to set and under various operating and measurement conditions, the indications may be helpful when used in a logical troubleshooting procedure.

The most common troubles in all kits are interchanged components, cold solder joints, and solder splashes. Another common trouble is blown transistors and ic's due to reverse polarity or power line transients. Remember if you encounter problems during initial testing that it is easy to install parts in the wrong place. Don't take anything for granted. Double check everything in the event of trouble.

### Current Drain.

Power line current drain normally is about 45 mA with volume turned down or squelched and up to 200 mA with full audio output.

If the current drain is approximately 100 mA with no audio output, check to see if voltage regulator U6 or U7 is hot. If so, and the voltage on the 8V or 5V line is low, there is a short circuit on that bus somewhere and U6 or U7 is limiting the short circuit current to 100mA to protect the receiver from damage. If you clear the short circuit, the voltage should rise again. U6 or U7 should not be damaged by short circuits on its output line; however, it may be damaged by reverse voltage or high transient voltages.

### Audio Output Stage.

Note that audio output ic U5 is designed to be heatsunk to the pc board through the many ground pins on the ic. When running moderately low au-

dio levels as most applications require, it is no problem to use an ic socket; so we have provided one for your convenience. If you will be running high audio levels, check to see if the ic is getting hot. If so, you should remove the ic socket, and solder the LM-386 ic directly to the board for better heatsinking.

If audio is present at the volume control but not at the speaker, the audio ic may have been damaged by reverse polarity or a transient on the B+ line. This is fairly common with lightning damage.

If no audio is present on the volume control, the squelch circuit may not be operating properly. Check the dc voltages, and look for noise in the 10 kHz region, which should be present at U1-pin 11 with no input signal. (Between pins 10 and 11 of U1 is an op-amp active filter tuned to 10 kHz.)

### RF Signal Tracing.

If the receiver is completely dead, try a 10.700 MHz signal applied to TP-3 using coax test lead. Set level just high enough for full quieting. At 1  $\mu$ V, you should notice some quieting, but you need something near full quieting for the test.

You can also connect the 10.700 MHz test lead through a blocking capacitor to various sections of the crystal filter to see if there is a large loss of signal across one of the filter sections. Also, check the 10.245 MHz oscillator with a scope or by listening with an hf receiver or service monitor.

A signal generator on the channel frequency can be injected at various points in the front end. If the mixer is more sensitive than the RF amplifier, the RF stage is suspect. Check the dc voltages looking for a damaged fet, which can occur due to transients or reverse polarity on the dc power line. Also, it is possible to have the input gate (gate 1) of the RF amplifier fet damaged by high static charges or high levels of RF on the antenna line, with no apparent change in dc voltages, since the input gate is normally at dc ground.

### Synthesizer Circuits.

Following is a checklist of things to look for if the synthesizer is suspected of not performing properly.

a. Check the output frequency of the vco buffer with a frequency counter.

c. Check tuning voltage at TP1. It should be about +2.0Vdc. Actual range over which the unit will operate

is about +0.5Vdc to about +4.5Vdc. However, for optimum results, the vco should be tuned to allow operation at about +2.0Vdc center voltage.

d. Check the operating voltage and bias on the vco and buffer.

e. Check the TCXO at pin 1 of the synthesizer ic. A scope should show strong signal (several volts p-p) at 10.240 MHz.

f. Check the oscillator at pin 1 of microcontroller ic U1 with a scope. There should be a strong ac signal (several volts p-p) at the oscillator frequency.

g. The data, clock, and latch enable lines between the microcontroller and synthesizer ic's should show very brief and very fast activity, sending data to the synthesizer ic shortly after the power is first applied or a dip switch setting is changed. Because this happens very fast, it can be difficult to see on a scope. Use 100 $\mu$ Sec/div, 5Vdc/div, and normal trigger.

h. Check the microcontroller to see that its /reset line is held low momentarily when the power is first applied. C1 works in conjunction with an internal resistor and diode in the ic to make C1 charge relatively slowly when the power is applied. It should take about a second to charge up.

i. Check the switch settings to be sure you have the correct frequency information going to the microcontroller.

### Microphonics, Hum, and Noise.

The vco and loop filter are very sensitive to hum and noise pickup from magnetic and electrical sources. Some designs use a shielded compartment for vco's. We assume the whole board will be installed in a shielded enclosure; so we elected to keep the size small by not using a separate shield on the vco. However, this means that you must use care to keep wiring away from the vco circuit at the right side of the board. Having the board in a metal enclosure will shield these sensitive circuits from fluorescent lights and other strong sources of noise.

Because the frequency of a synthesizer basically results from a free running L-C oscillator, the tank circuit, especially L1, is very sensitive to microphonics from mechanical noise coupled to the coil. You should minimize any sources of vibration which might be coupled to the receiver, such as motors. In addition, it helps greatly to prevent the molded coil from

vibrating with respect to the shield can. Both the coil and can are soldered to the board at the bottom, but the top of the coil can move relative to the can and therefore cause slight changes in inductance which show up as frequency modulation. Therefore, the factory cements the top of the coil to the can.

Excessive noise on the dc power supply which operates the receiver can cause noise to modulate the synthesizer output. Various regulators and filters in the receiver are designed to minimize sensitivity to wiring noise. However, in extreme cases, such as in mobile installations with alternator whine, you may need to add extra filtering in the power line to prevent the noise from reaching the receiver.

Other usual practices for mobile installations are recommended, such as connecting the + power and ground return lines directly to the battery instead of using cigarette lighter sockets or dash board wiring.

To varying degrees, whine from the 5kHz reference frequency may be heard on the signal under various circumstances. If the tuning voltage required to tune the vco on frequency is very high or low, near one extreme, the whine may be heard. This can also happen even when the tuning voltage is properly near the 2.0Vdc center if there is dc loading on the loop filter. Any current loading, no matter how small, on the loop filter causes the phase detector to pump harder to maintain the tuning voltage. The result is whine on the signal. Such loading can be caused by connecting a voltmeter to TP1 for testing, and it can also be caused by moisture on the loop filter components.

### Typical Dc Voltages.

Tables 4-6 give dc levels measured with a sensitive dc voltmeter on a sample unit with 13.6 Vdc B+ applied. All voltages may vary considerably without necessarily indicating trouble. The charts should be used with a logical troubleshooting plan. All voltages are positive with respect to ground except as indicated.

Use caution when measuring voltages on the surface mount ic. The pins are close together, and it is easy to short pins together and damage the ic. We recommend trying to connect meter to a nearby component connected to the pin under question. Also, some pins are not used in this design, and you can generally not be concerned with making measurements on them.

## Typical Audio Levels.

Table 7 gives rough measurements of audio levels. Measurements were taken using an oscilloscope, with no input signal, just white noise so conditions can be reproduced easily.

## REPAIRS.

If you need to unsolder and replace any components, be careful not to damage the plated through holes on the pc board. Do not drill out any holes. If you need to remove solder, use a solder sucker or solder wick. A toothpick or dental probe can be used with care to open up a hole.

If you need to replace a surface mount ic, first be very sure it is damaged. Then, carefully cut each lead off the case with fine nose cutters. Once the case is removed, individual leads can be unsoldered and the board can be cleaned up. Carefully position the new ic, and tack solder the two opposite corner leads before any other leads are soldered. This allows you to melt the solder and reposition the ic if necessary. Once you are sure, the remaining leads can be soldered. If you get a solder short between leads, use a solder sucker or solder wick to remove the excess solder.

**Table 6. Typical IC DC Voltages**

U1-1	2.3	U4-1	8
U1-2	2.3	U4-2	7.5
		U4-3	7.8
U2-1	2.1	U4-4	8
U2-2	1.9	U4-5	7.5
U2-3&4	4.9	U4-6	7.5
U2-5	0 – 5V (~2V tuned)	U4-7	7.5
		U4-8	8
U2-7	4.8	U4-9	3.3
U2-8	1.6	(aligned)	
U2-9	0	U4-10	0.75
U2-10	0	U4-11	1.5
U2-11	0	U4-12	0.6 (with squelch just closed)
U5-1	1.35	U4-13	0 (sq open)
U5-3	0.05		7.5 (sq closed)
U5-5	6.8	U4-14	0
U5-6	13.6	U4-15	0
U5-7	6.9	U4-16	1.8
U5-8	1.35		

**Table 7. Typical Audio Voltages**

Audio Test Point	Normal Level
U4-9 (Discriminator)	3V p-p audio
E4 (Disc Output)	2V p-p audio
E1 (Repeater Output)	1V p-p audio
U4-11 (noise ampl)	2.5V p-p noise
Right lug of Vol cont.	500mV p-p audio
U5-2 (af ampl input)	0 to 300mV p-p
U5-6 or E2 (speaker ampl output)	0 to 7V p-p audio

**Table 4. Typical Test Point Voltages**

TP1	Tuning V.	Normally set at 2V
TP2	Buffer	approx. 0.35V
TP3	Test Input	(No reading)
TP4	Sig. Level	With SQUELCH control fully ccw, varies from -0.5 Vdc with no to +1 Vdc full quieting.
E4	Freq.	Varies with frequency of input signal. Voltage at this point normally is ad- justed for +3.3Vdc with a signal exactly on fre- quency. Can vary a little without being a problem.

**Table 5. Typical Xstr DC Voltages**

Xstr	Stage	E(S)	B(G1)	C(D)	G2
Q1	vco	1.3	2.0	6.5	-
Q2	buffer	0	0.7	4.5	-
Q3	dc filter	6.8	7.4	7.6	-
Q4	RF ampl	0	0	7.5	3.8
Q5	Mixer	0	0	7.6	0
Q6	sq. open	0	0	8	-
	sq. closed	0	0.65	0.1	-

## PARTS LIST FOR R302 RECEIVER.

☞ Note: Values which vary with freq. band are shown in a table at the end of the parts list. Resistors and capacitors are 805 smt type unless noted otherwise.

⚡ Caution: IC's are static sensitive. Use appropriate handling precautions to avoid damage.

### Ref Desig Value (marking)

C1	1 µf electrolytic
C2	100pf
C3	0.1µf
C4	not assigned
C5	0.1µf
C6	100µf electrolytic
C7	not assigned
C8	0.1µf
C9	100µf electrolytic
C10	0.15µf mylar (red)
C11	.01µf
C12	.001uf
C13	2pf
C14	100µf electrolytic
C15	0.1µf
C17-C18	390pf
C19	100µf electrolytic
C22	4pf
C23	390pf
C26-C27	390pf
C30	not assigned
C32	0.3pf
C34	0.3pf
C36	4pf
C40	.01µf
C41	5pf
C42	6pf
C43	5pf
C44	0.47µf electrolytic
C45	0.1µf
C46-C47	.001uf
C48	0.1µf
C49-C50	.01µf
C51	220µf electrolytic
C52	10µf electrolytic
C53	1µf electrolytic
C54	100µf electrolytic
C55	.001µf
C56	220pf
C57	68pf
C58-C60	0.1µf
D1	BB132 varactor diode
D2-D4	MMBT3904 (used as diode)
FL1-FL4	10.7MHz crystal filter (matched set of 4)
FL5	455kHz ceramic filter
J1	RCA Jack
L2	0.33µH RF choke (red-sil-orn-orn)
L3-L8	2½ t. ,slug tuned (red)
L9	0.33µH RF choke (red-sil-orn-orn)
Q1-Q2	MSC3130
Q3	MMBT3904
Q4-Q5	BF998 MOS FET

Q6	MMBT3904
R1	180Ω
R2	2.2K
R3	2 Meg
R4	27Ω
R5	10K
R6	47K
R7-R8	2.2K
R9	10K
R10	6.8K
R11	3.9K
R12	180Ω
R13	47Ω
R14	15K
R15	470Ω
R16	3.9meg
R17-R18	100K
R19	47K
R20	330K
R21	15K
R22	47K
R23	100K panel mount pot
R24	47K
R25	100K
R26	47K
R27	510K
R28	4.7K

R29	680Ω
R30	1K
R31	22K
R32	100K panel mount pot.
R33-R34	not assigned
R35	47K
R36	100K
R37	2Meg
R38	27Ω
R39	100Ω
R40-R42	27Ω
S1	11 pos. DIP switch
T1	10.7MHz IF xfmr (7A-691F)
T2	455kHz IF xfmr (T1003)
T3	10.7MHz IF xfmr (7A-691F)
U1	MC68HC705J1A µP
U2	LMX1501A PLL
U3	10.240 MHz TCXO
U4	MC3361BP IF ampl
U5	LM386N-1 AF output
U6	78L08ACD regulator
U7	78L05ACD regulator
Y1	10.245 MHz crystal

### Values which vary with frequency band:

R302-1 is 138.000 - 144.000 MHz  
R302-2 is 144.000 - 154.235 MHz  
R302-3 is 154.200 - 164.435 MHz  
R302-4 is 164.400 - 174.635 MHz  
R302-B is 178.000 - 182.000 MHz  
R302-5 is 216.000 - 226.235 MHz  
R302-6 is 220.000 - 230.235 MHz

Ref	-1	-2	-3	-4	-B	-5, -6
C16	10	10	10	10	7	8
C20	18	15	12	10	6	10
C21	68	68	62	47	33	47
C24	39	33	27	22	15	10
C25	68	62	47	47	39	33
C28	33	27	22	20	15	8
C29	68	68	62	62	39	27
C31	22	20	18	15	12	6
C33	22	20	18	15	12	8
C35	20	18	15	12	10	6
C37	39	27	22	20	18	10
C38	82	82	62	62	47	27
C39	1	1	1	0.5	0.5	0.3
L1	2½t (red)	2½t (red)	2½t (red)	2½t (red)	2½t (red)	1½t (dark brown)

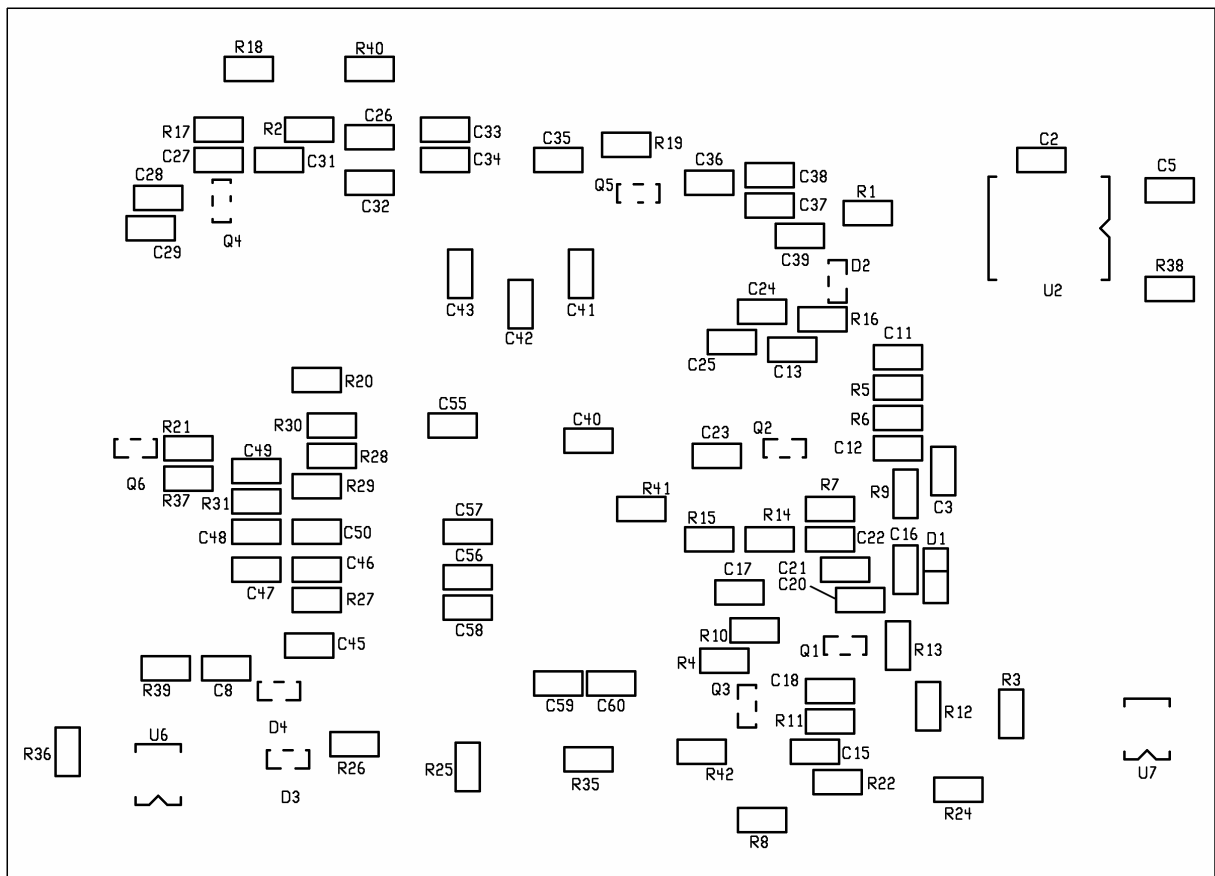
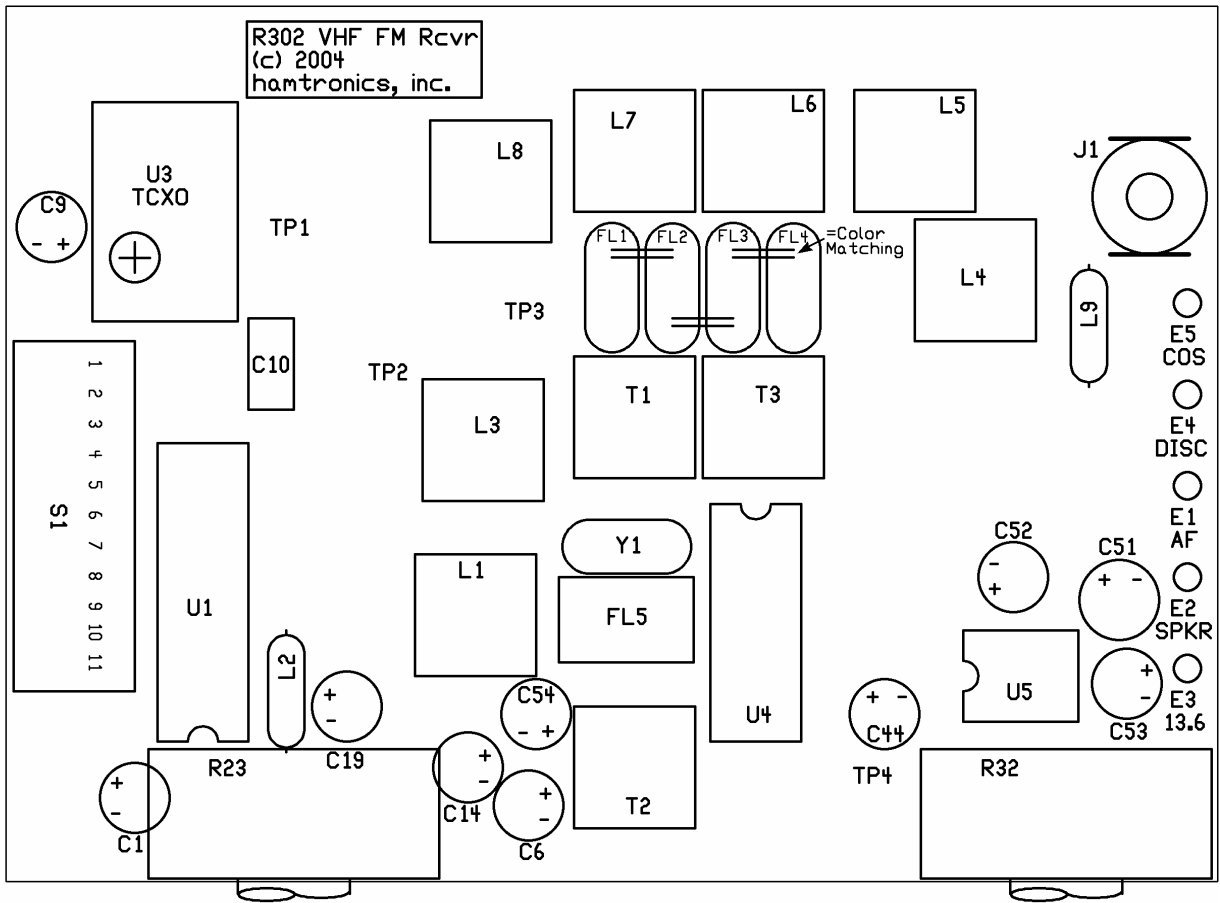



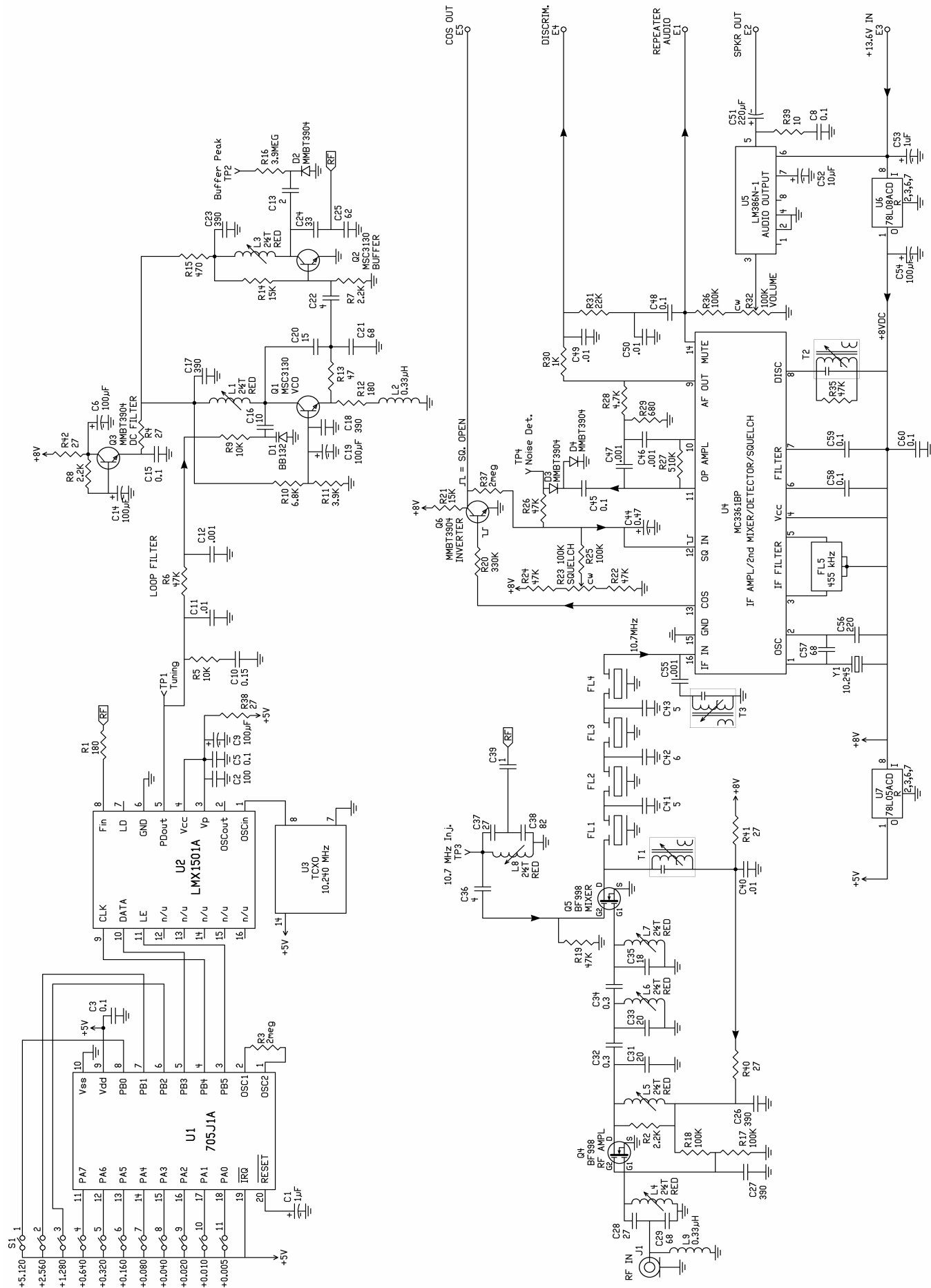

Figure 3. R302 VHF FM Receiver, Schematic Diagram.  
 (Note: Values are for 144MHz version. See parts list for other bands.)