

# HAMTRONICS® RPA-302 UHF REPEATER POWER AMPLIFIER ASSEMBLY, OPERATION, & MAINTENANCE INSTRUCTIONS

## CONSTRUCTION.

a. Set heatsink on bench, oriented as in figure 1. Note where PA transistor is to be mounted to two adjacent holes. Align the pc board with the heatsink, matching the cutout for the transistor and the pc board mounting holes with the holes on the heatsink. *Note that the heatsink is used for several products; so there may be extra holes to the left of the pc board which are not used in this model.*

b. Temporarily remove the pc board, and lay it on a box or hold it in a vise horizontally with the etched side of the board up. Using a sharp pick or any other convenient tool, pick up eyelets and place them in the small holes on the board. The heads of the eyelets must rest flat against the foil on the etched side of the board. Then, using a small amount of solder, solder the heads of the eyelets to the foil. The eyelets connect the pc board front and rear ground planes together at critical locations. Be sure all small holes are thus connected through. If you lose an eyelet, bus wire can be used.

c. Turn the pc board over, and solder the other side of the eyelets to the ground plane. Be sure all are soldered, and check to make sure none have slipped back through the other side. If so, heat eyelet flange on top side of board until solder on both sides melts, and push eyelet gently back in place. Note that it is especially important that the 8 eyelets under the emitter leads of Q1 are

properly seated and that no solder blobs protrude above eyelet heads. This is to prevent stress on transistor leads when it is later installed.

d. Set two #8 flat washers over each of the 3 enclosure holes used to mount the pc board (not the 2 transistor holes). *The two washers provide the proper thickness for the pc board spacing needed for the transistor; so be sure to use the ones supplied to prevent damage to the transistor.* Set the pc board in place, and secure with three each 6-32 x 3/8 inch thread cutting screws. The screws go through the pc board and spacer washers and thread into the aluminum heatsink. *Be careful not to over tighten the screws and strip the threads.*

e. Locate the power transistor, and note that the collector lead is the narrow one (see component location diagram). The collector lead should face the right-hand side (toward connectors). Apply a small amount of heatsink compound to the bottom surface of the transistor, and set it in place through the cutout in the board.

f. Secure the transistor with two 4-40 x 1/2 inch screws inserted through the transistor flange into the heatsink. Use lockwashers and nuts on the fin side of the heatsink. Align the transistor with the board before tightening screws.

*Refer to the pc board component location diagram in the rear of the manual for the following assembly operations.*

g. Solder the six transistor leads to the pc board. It is important to solder the entire surface of each lead and use enough solder to form a bond under the leads.

h. Install the metal clad mica capacitors in the exact positions shown. The flat side with the value markings should be up. Bend the tabs down so they just touch the board with the case flat against the board. Hold each capacitor in place and solder the tab to the board. Then, solder each side of the metal case to the ground plane. C3-C6 should be over the emitter leads, as close to the body of the transistor as possible. C7 should have its tab bent up slightly. It acts as a free-standing terminal above the board. Its tab does not connect to the board, just the case.

i. Solder the mylar and disc capacitors and the electrolytic capacitor (C9-C11) in place as shown. The .01uF capacitor may be marked "103". The mylar capacitor is red. Observe polarity of electrolytic capacitor. C11 is connected from the tab of C7 to ground.

i. Cut a brass strap 3/16 x 1 inch (approx.), and solder it down to complete the stripline from the base of Q1 to the hole under the position of C2 on the diagram. (This pc board was originally designed for another PA which had a driver transistor which is not used in this model.)

k. Solder the tabs of variable mica capacitor C12 in the position shown, between two pads on the pcb.

l. Prepare the three piston capacitors by cutting off the two narrow lugs from the bottom of the main body of each capacitor. Bend the narrow lugs at the end of the rotor straps over at a 90-degree angle away from the capacitor.

m. Set C2 in place on the board as shown and tack solder in place. It will be necessary to bend the rotor strap out away from the capacitor body at an angle to straddle the large hole in the board. The capacitor itself can be installed on a slight angle, and the strap will be at an angle. Tack solder the lugs at the bottom of the main body of the capacitor first and then the rotor strap.

n. Likewise, set C1 in place and solder to the board with the two lugs

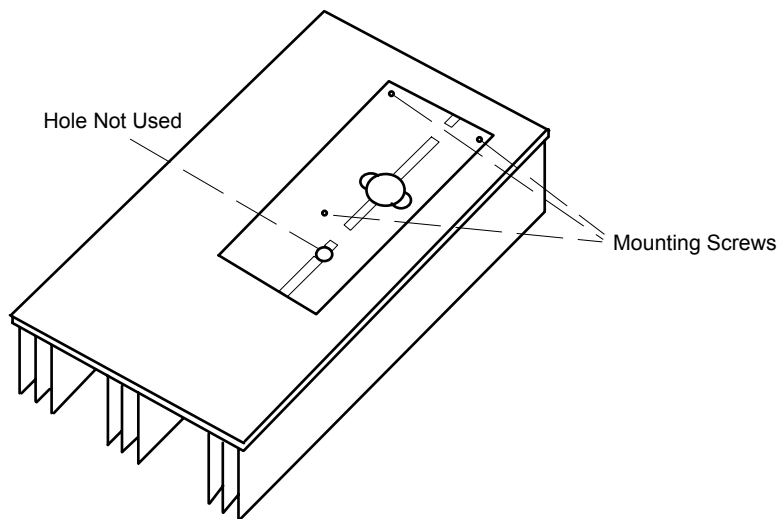

Figure 1. View of Heatsink

at the bottom of the body of the capacitor soldered to the stripline, and the rotor strap soldered to the ground plane.

o. Install C13 on the board with the lugs at the bottom of the body soldered to the ground plane next to the mounting screw and the rotor strap to the adjacent pad by C12.

p. Wind coil L1 as shown in the diagram from #18 bus wire supplied. It is 1/4 inch inside diameter; so it can be formed around a 1/4 inch drill bit or other rod. L1 has three turns barely spaced. Solder L1 leads from the tab of C7 to the stripline in the position shown. The bottom of the coil should be just above the board.

q. Ferrite chokes Z1 and Z2 are 6-hole balun cores with 1-1/2 turns of #22 bus wire threaded through the holes in the manner shown in the diagram. The turns go only through the holes, not around the outside of the core, except at the ends. Cut a 3-inch length of wire. Feed it through a hole with about 1/2 inch protruding, and hold this short end. Then, thread the long end through the adjacent hole and pull tight. Thread through a third hole as shown until 1/1-2 turns are complete. (Three holes are not used.) Tack solder the leads of the balun chokes to the board in the positions shown. One end of Z2 is soldered to the tab of C7.

r. Solder Z1 in place, with short leads, from the base of Q1 to ground, positioned as shown.

s. Solder a length of hookup wire to the pad by C10 to provide +13.6 Vdc operating power when the unit is used.

t. Coax cables for the input and output are soldered directly to the board. Strip a length of 50 ohm coax and solder to input of board. Keep stripped lead lengths to no more than 1/4 inch to avoid losses. The center lead at the pc board must be connected at the very end of the stripline as shown.

u. Solder another piece of coax to the output of the board as shown.

v. Cut the leads of a 10pf disc capacitor to about 1/8 inch. Carefully tack solder this capacitor to the front side of piston capacitor C2 as shown in the parts location diagram.

w. Check to be sure all parts have been installed. Check for poten-

tial short circuits and other workmanship problems. Double check circuit to schematic diagram.

## ALIGNMENT

**CAUTION:** Do not screw rotor screws of piston capacitors down so far that they touch the pc board under the body of the capacitor. Doing so would cause a short circuit and possibly cause damage. The screw bottoms out when the top of the screw protrudes less than about 1/4 inch from the top of the capacitor.

a. Preset the variable capacitors as follows:

- Mica capacitor C12: 1 turn from full clockwise.
- Piston capacitor C1: 5/16 inch of screw exposed.
- Piston capacitor C2: 3/16 inch of screw exposed.
- Piston capacitor C13: 1/2 inch of screw exposed.

b. Connect input coax cable to repeater output or other source of 8-10 Watts drive. Connect output cable through power meter to a good uhf 50 ohm dummy load.

c. Connect regulated +13.6Vdc power source to dc input wire and power supply ground to ground plane on board. (If your power supply has adjustable voltage, it is better to start tuning with about 10Vdc and increase it to 13.6 Vdc after you determine there are no problems.)

*Note: Do not retune repeater output stage or other driving source with PA connected.* Driving source should be tuned into 50 ohm load and left alone afterwards. Input of PA is tuned then to present 50 ohm load to driver.

d. Apply drive to PA, and alternately adjust C1, C2, C12, and C13 for maximum output. Do this several times to work out any interactions. Use an insulated tool with a small metal screwdriver bit in the end.

e. When fully tuned, the PA should deliver about 30 to 40 Watts with 8-10 Watts drive when using a 13.6Vdc power supply. If the dc voltage is low, the output will be less. You may also experience considerable loss in the output coax if it is not a good low-loss uhf type. The PA will draw about 6 to 7 Amp at full output.

*Note: It is normal for C12 to be near full clockwise and C13 to be near mini-*

*um capacitance (screw exposed about 1/2 inch).*

## MOUNTING.

There is no special way to mount the PA. However, for repeater service, complete shielding is required. Therefore, some sort of enclosure should be used which would leave just the fins of the heatsink on the outside.

## POWER.

The PA requires well-regulated 13.6Vdc, free of transients, at about 6 to 7 Amp. An 8 Amp continuous-duty power supply would have some reserve. Use fairly short, heavy leads to connect power supply to the pc board. If there are any relays or other inductive devices on the same power supply, be sure to put a reverse diode across the device to absorb reverse voltage spikes generated by inductive kick-back. It would be wise to connect an 8 Amp, fast-acting fuse in series with the PA power lead if the power supply is capable of more than 8 Amps.

*CAUTION: RF power transistors are fully tested by the manufacturer and are not under warranty because they are easily damaged by physical or electrical accidents. They are very expensive to replace. Be sure to use adequate precautions to avoid damage.*

## OPERATION.

Once tuned, the PA will automatically operate when sufficient drive is applied. Since it operates class C, it will draw no current when no rf power is applied. It is designed for continuous duty.

## REPAIR.

Should it be necessary to replace the transistor, be sure to use an exact replacement. To remove old transistor, carefully peel each lead away from the pc board while applying heat to melt solder. Then, remove transistor from unit, and clean excess solder from board. This is important to avoid tearing leads from new transistor when hardware is tightened. Also, clean off old heatsink compound, which may be dirty, and apply a fresh coat to the new transistor. Remember to resolder any components removed for access to transistor.

