

HAMTRONICS® RPA-402 220 MHZ REPEATER POWER AMPLIFIER ASSEMBLY, OPERATION, & MAINTENANCE INSTRUCTIONS

CONSTRUCTION.

a. Set heatsink on bench. Note where PA transistor is to be mounted to two adjacent holes. Align the pc board with the heatsink, matching the cutout for the transistor and the pc board mounting holes with the holes on the heatsink. *Note that the heatsink is used for several products; so there may be extra which are not used in this model.*

b. Temporarily remove the pc board, and set two #8 flat washers over each of the four mounting holes on the heatsink to use as spacers. *The two washers provide the proper thickness for the pc board spacing needed for the transistor. Be sure to use the ones supplied to prevent damage to the transistor.* Set the pc board in place, and secure with four each 6-32 x 3/8 inch thread cutting screws. The screws go through the pc board and spacer washers and thread into the aluminum heatsink. *Be careful not to over tighten the screws and strip the threads.*

c. Locate the power transistor, and note that the collector lead is the narrow one (see component location diagram). The collector lead should face the right-hand side (toward connectors). Apply a small amount of heatsink compound to the bottom surface of the transistor, and set it in place through the cutout in the board.

d. Secure the transistor with two 4-40 x 1/2 inch screws inserted through the transistor flange into the

heatsink. Use lockwashers and nuts on the fin side of the heatsink. Align the transistor with the board before tightening screws.

Refer to the pc board component location diagram in the rear of the manual for the following assembly operations.

e. Solder the six transistor leads to the pc board. It is important to solder the entire surface of each lead and use enough solder to form a bond under the leads.

f. Install the metal clad mica capacitors in the exact positions shown. The flat side with the value markings should be up. Bend the tabs down so they just touch the board with the case flat against the board. Hold each capacitor in place and solder the tab to the board; then, solder each side of the metal case to the ground plane. C6, C7, C15, and C16 should be over the emitter leads.

g. Solder C11, C12, and C13 in place as shown. The .01uF capacitor may be marked "103". The 0.15 uF mylar capacitor is red. Observe polarity of electrolytic capacitor C13.

h. Install variable mica capacitors C1-C3, and C8 as shown, and solder them in the exact positions shown, which leaves room for the coils. The leads need not be bent; they will stand up on the board as is.

i. Form hairpin coils L1-L3 as shown in the component location diagram, using #14 bus wire supplied. Coils are soldered with the feet (see detail) flat against the board.

j. Ferrite chokes Z1-Z3 are 6-hole balun cores with 2 1/2 turns of #22 bus wire threaded through the holes in the manner shown in the detail. The turns go only through the holes, not around the outside of the core, except at the ends. Cut a 3-inch length of wire. Feed it through a hole with about 1/2 inch protruding, and hold this short end. Then, thread the long end through the adjacent hole and pull tight. Thread through a third hole as shown until 2 1/2 turns are complete. (One hole is not used.) Tack solder the leads of the balun chokes to the board in the positions shown.

k. Solder the two resistors in place with short leads. R1 goes from the base of Q1 to ground, positioned as shown. R2 goes across balun choke Z2.

l. Solder a length of hookup wire to the pad by C10 to provide +13.6 Vdc operating power when the unit is used.

m. Coax cables for the input and output are soldered directly to the board. Strip a length of 50 ohm coax and solder to input of board. Keep stripped lead lengths to no more than 1/4 inch to avoid losses. The center lead at the pc board must be connected at the very end of the stripline as shown.

n. Solder another piece of coax to the output of the board as shown.

o. Check to be sure all parts have been installed. Check for potential short circuits and other workmanship problems. Double check circuit to schematic diagram.

ALIGNMENT

a. Preset the variable capacitors about 1 1/2 turns ccw from fully tight.

b. Connect RF Input to repeater output or other source of 15 Watts drive. Connect RF Output through power meter to a good 50Ω vhf dummy load.

c. Connect regulated +13.6Vdc power source to dc input wire and power supply ground to ground plane on board. (If your power supply has adjustable voltage, it is better to start tuning with about 10Vdc and increase it to 13.6 Vdc after you determine there are no problems.)

Note: Do not retune repeater output stage or other driving source with PA

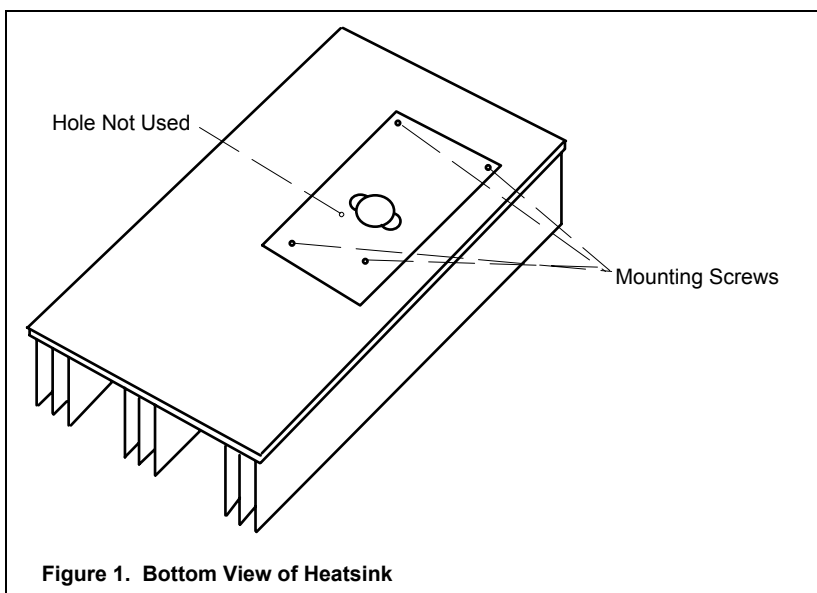

Figure 1. Bottom View of Heatsink

connected. Driving source should be tuned into 50 ohm load and left alone afterwards. Input of PA is tuned then to present 50 ohm load to driver.

d. Apply drive to PA, and alternately adjust C1/C8 and C2/C3 for maximum output. Do this several times to work out any interactions. Use an insulated tool.

e. When fully tuned, the PA should deliver about 45 to 55 Watts with 13-15 Watts drive when using a 13.6Vdc power supply. If the dc voltage is low, the output will be less. You may also experience a little loss in the output coax if it is not a good low-loss type. The PA will draw about 6 to 7 Amp at full output.

MOUNTING.

There is no special way to mount the PA. However, for repeater service, complete shielding is required. Therefore, some sort of enclosure should be used which would leave just the fins of the heatsink on the outside.

POWER.

The RPA-402 requires well-regulated 13.6Vdc, free of transients, at about 6 to 7 Amp. An 8 Amp continuous-duty power supply would have some reserve. Use fairly short, heavy leads to connect power supply to the pc board. If there are any relays or other inductive devices on the same power supply, be sure to put a reverse diode across the device to absorb reverse voltage spikes generated by inductive kick-back. It would be wise to connect an 8 Amp, fast-acting fuse in series with the PA power lead if the power supply is capable of more than 8 Amps.

CAUTION: RF power transistors are fully tested by the manufacturer and are not guaranteed because they are easily damaged by physical or electrical abuse. They are very expensive to replace. Be sure to use adequate precautions to avoid damage.

OPERATION.

Once tuned, the RPA-402 will automatically operate when sufficient drive is applied. Since it operates class C, it will draw no current when no rf power is applied. It is designed for continuous duty at up to 55 Watts. Do not operate it above that level. Reduce drive if necessary so it will operate at this level, which is sufficiently conservative if heatsink is not blocked and ambient temperature is below 100 degrees F.

REPAIR.

Should it be necessary to replace the transistor, be sure to use an exact replacement. To remove old transistor, carefully peel each lead away from the pc board while applying heat to melt solder. Then, remove transistor from unit, and clean excess solder from board. This is important to avoid tearing leads from new transistor when hardware is tightened. Also, clean off old heatsink compound, which may be dirty, and apply a fresh coat to the new transistor. Remember to resolder any components removed for access to transistor.

