

HAMTRONICS® T301 VHF FM EXCITER, REV F: INSTALLATION, OPERATION, & MAINTENANCE

GENERAL INFORMATION.

The T301 is a single-channel vhf fm exciter designed to provide 2 to 3½ Watts continuous duty output into a 50 ohm antenna system in the 144 MHz ham band or 148-174 MHz commercial band. Another model covers the 216-226MHz band or the 220-230MHz band. Operating power is +13.6 Vdc ±10% at 450-600 mA. There are several models, which have minor variations in parts and microcontroller programming, to provide coverage as shown in table 1. Channel frequency is controlled by a synthesizer with DIP switch channel setting.

A temperature controlled xtal oscillator (TCXO) provides a temperature stability of ±2ppm over a temperature range of -30°C to +60°C.

The Exciters are designed for narrow-band fm with ±5 kHz deviation. The audio input will accept a standard low-impedance dynamic microphone or any low-impedance audio source capable of providing 40mV p-p minimum into a 1K load.

INSTALLATION.

Mounting.

The four mounting holes provided near the corners of the board can be used with standoffs to mount the board in any cabinet arrangement. (See catalog for A26 PC Mounting Kits and A88 Cabinets.) There is no need for a shielded cabinet except if the exciter is used in a repeater or in duplex service; however, shield the exciter from any power amplifier.

Electrical Connections.

Power and input audio or data signals should be connected to the solder pads on the **BOTTOM** of the board with #22 solid hookup wire. Be very careful not to route the wiring near the right hand side of the board, which contains sensitive loop filter and vco circuits which could pick up noise from the wiring. Also avoid routing wiring along the rf amplifier circuits on the top of the board or under the board. Keep all wiring at the left and bottom sides of the board.

Power.

The T301 Exciter operates on +13.6 Vdc at about 450-600 mA. A well regulated power supply should be used. Positive and negative power leads should be connected to the exciter at E1 and E3. Be sure to observe polarity, since damage to the transistors will occur if polarity is reversed.

When you key the exciter, it takes about 400-500 milliseconds for the synthesizer to come on. This delay normally is not a prob-

lem. However, if you have an application which requires the rf output to be available instantly, you can apply power to the synthesizer all the time and only key the power to the amplifier stages.

Repeaters are one application where you might notice the delay; however, if you use a normal tail time setting on the repeater, the carrier will stay on all the time during a qso and only go off when everyone is finished using the repeater.

Normally, E1 and E4 are jumpered together by a trace on the bottom of the pc board. If you want to use E4 independently, use a tool to make a cut through that trace. Then, connect E4 to constant +13.6Vdc and connect E1 to the keying switch, e.g., the keyed B+ output of one of our repeater controller modules. Make sure that the keying circuit you use is capable of supplying up to 600 mA needed for E1. Current drain to power the synthesizer circuits separately at E4 is only about 30 mA.

Antenna Connections.

The antenna connection should be made to the pc board with an RCA plug of the low-loss type made for rf. We sell good RCA plugs with cable clamp. See A5 plug on website.

If you want to extend the antenna connection to a panel connector, we recommend using a short length of RG-174/u coax with the plug and keep the pigtailed very short.

We do **not** recommend trying to use direct coax soldered to board or another type of connector. The method designed into the board results in lowest loss practical. When soldering the cable, keep the stripped ends as short as possible.

Audio Connections.

The T301 Exciter is designed for use with a low impedance dynamic mic (500-1000 ohms) or any low impedance audio source capable of supplying 40 mV p-p across 1000Ω. The microphone should be connected with shielded cable to avoid noise pickup. Higher level audio inputs, such as from a repeater controller, may not need to be shielded. Mic connections are made to E2 and E3 on the pc board. *Be sure to dress the audio cable away from any RF circuits.*

RF Output Connection.

To connect to the pc board, use a good quality RCA plug with a metal cable clamp and a short center pin. If you cannot find a suitable plug, you can solder coax directly to the pc board, but keep the pigtailed as short as possible to minimize loss.

Subaudible Tone Connections.

If you want to transmit a CTCSS (subaudible) tone, you can connect the output of the tone encoder directly to CTCSS INPUT pad E5. This is a direct input to the modulator and bypasses all the audio processing.

Because this input is dc coupled, it is necessary to check the CTCSS Encoder unit to be sure the its output is ac coupled (has a blocking capacitor). Otherwise, the dc center voltage of the modulator will be upset. Note that the CTCSS Encoders we manufacture already have such a blocking capacitor; so nothing special is required. However, if you use some other encoder which does not have a blocking capacitor built in, it is necessary to add a 0.1µF capacitor in series with the input to E5 on the Exciter.

The level of the subaudible tone should be set no higher than about 300 Hz deviation for best results. Otherwise, a buzz may be heard on the audio at the receiver. Good CTCSS decoders can easily detect tones with less than 100Hz deviation.

ADJUSTMENTS.

Frequency Deviation Adjustments.

Set deviation limit pot R35 for the proper maximum deviation (normally ±5kHz) and then set af gain pot R26 for gain just sufficient to drive the audio up to full deviation on peaks. Since the deviation limit pot is after the limiter, it sets the absolute maximum deviation assuming the input signal is driven into limiting.

To adjust the audio controls, start by setting the af gain pot to maximum. Apply power to the exciter and talk into the microphone or apply audio of normal expected level to the exciter.

If the unit is setup with tones from a service monitor, use a tone frequency of 1000 Hz. Observe the deviation scope on a service monitor, and adjust the deviation limit pot for a peak deviation of 5 kHz. Then, adjust the af gain pot so that the exciter deviation just

Table 1. Quick Specification Reference

Model T301-1	138.000 - 148.235 MHz
Model T301-2	144.000 - 154.235 MHz
Model T301-3	154.200 - 164.435 MHz
Model T301-4	164.400 - 174.635 MHz
Model T301-5	216.000 - 226.235 MHz
Model T301-6	220.000 - 230.235 MHz

Operating Voltage: +13.6Vdc ±10%
Operating Current: 450 mA @ 2W out
550 mA @ 3W out
650 mA @ 4W out
Operating Current, Synth only: 30 mA
Audio Input: 40 mV p-p min. into 1KΩ
Size: 5 in. W x 3 in. D

swings up to 5 kHz on modulation peaks.

This will provide the optimum setting, with sufficient audio gain to achieve full modulation but with the limiter occasionally clipping voice peaks to prevent over-modulation. Avoid setting the audio gain higher than necessary. Although the deviation limiter will prevent over-modulation, background noise is increased and some distortion from excessive clipping may result.

Frequency Readjustment.

All crystals age a little over a long period of time; so it is customary to tweak any transmitter back onto the precise channel frequency once a year during routine maintenance.

The adjustment should be done using an accurate service monitor or frequency counter. Of course, make sure the test equipment is exactly on frequency first by checking it against WWV or another frequency standard. No modulation should be applied to the transmitter during the adjustment period.

The channel frequency is trimmed precisely on frequency with a small variable capacitor, which is accessible through a hole in the top of the TCXO shield can. The proper tool is a plastic wand with a small metal bit in the end. (See A2 Alignment Tool on our website.)

Setting Channel Frequency.

The channel frequency is determined by frequency synthesizer circuits, which use a dip switch in conjunction with programming in a microcontroller to set the channel. The microcontroller reads the dip switch information and does mathematics, applying serial data to the synthesizer ic whenever power is applied. Following is a discussion of how to set the dip switch to the desired channel frequency.

NOTE: *If the frequency is changed more than about 500 kHz, a complete alignment of the Exciter should be performed, as described in later text. Optimum operation only occurs if the synthesizer is adjusted to match the frequency switch setting and all the tuned amplifier circuits are peaked for the desired frequency.*

To determine what channel frequency to use, the microcontroller adds the frequency information from the dip switch to a "base"

frequency stored in eeprom used for microcontroller programming. Each model of the T301 Exciter has a particular base frequency. For example, the T301-2 has a base frequency of 144.000 MHz, as shown in Table 1.

Dip switch settings are binary, which means each switch section has a different weighting, twice as great as the next lower section. Sections have weights such as 5 kHz, 10 kHz, etc., all the way up to 2.56 MHz. (See Table 2 or the schematic diagram for switch values.) For very large increments, there is even a jumper which can be added to the board between E6 and E7 for a 5.12 MHz increment, although this is rarely used, except on commercial bands.

Begin by subtracting the base frequency, e.g., 144.000, from the desired frequency to determine the total value of all the switch sections required to be turned on.

For starters, if the difference is less than 5.120 MHz, you don't need to jumper E6 to E7.

If the difference is greater than 2.560 MHz, turn on switch #1, and subtract 2.560 from the difference frequency to determine the remainder. Otherwise, skip switch #1.

Do the same for each of the other sections, from highest to lowest weighting, in sequence. Each time you consider the remainder, turn on the switch section with the highest weighting which will fit within the remainder without exceeding it. Each time it is found necessary to turn on a switch section, subtract the value of that section from the remainder to get the new remainder.

As an example, let us consider how to set the Exciter for output on 146.94 MHz. The following discussion is broken down into steps so you can visualize the process easier.

a. $146.940 - 144.000$ base freq. = 2.940 MHz remainder. Turn on switch #1, which represents the largest increment to fit remainder.

b. $2.940 - 2.560$ value of switch #1 = 0.380 MHz. Turn on #4, which is 0.320 MHz, the largest increment to fit the remainder.

c. $0.380 - 0.320 = .060$ MHz remainder. Turn on switch #7 and switch #8, which have values of .040 and .020, respectively, which adds up to the remainder of .060 MHz.

d. When we finished, we had turned on switch sections 1, 4, 7, and 8.

Note: Dip switch information is read by the synthesizer only when power is first applied. If switch settings are changed, turn the power off and on again.

Shortcut ---

If you have access to the internet, our website has a long table of numbers which gives the equivalent binary number settings for every possible frequency. We couldn't print it here because it takes many printed pages of space. Surf to our website at www.hamtronics.com and look for Dip Switch

Freq Programming for T301 under Reference Info near the bottom of the Table of Contents. Look up the frequency, and it will give you all the binary switch settings.

ALIGNMENT.

General Procedure.

A complete alignment is needed whenever the frequency is changed by more than about 500 kHz. Alignment ensures that the frequency synthesizer is optimized at the center of the vco range and that all RF amplifier stages are tuned to resonance.

Equipment needed for alignment is a dc voltmeter, a good vhf 50 ohm RF dummy load, an RF wattmeter accurate at vhf, and a regulated 13.6Vdc power supply with a 0-1000 mA meter internally or externally connected in the supply line.

The slug tuned coils in the exciter should be adjusted with the proper tuning tool to avoid cracking the powdered iron slugs. The models covering bands below 216MHz use the A1 hex tool shown on our website. Models above 216MHz use the A28 square tip tool. Variable capacitors should be adjusted with a plastic tool having a small metal or ceramic bit, such as the A2 tool.

NOTE: *Following are some ground rules to help avoid trouble. Always adhere to these guidelines.*

1. *Do not operate without a 50 ohm load. The output transistor could be damaged from overheating.*

2. *Class C amplifiers can become spurious if under driven. Therefore, do not attempt to reduce power output by detuning the drive. Better ways to reduce output substantially are to reduce the B+ to as low as 10Vdc by adjusting the power supply or to remove the output transistor and replace it with a blocking capacitor if you really want low output.*

3. *RF power transistors Q5 and Q6 run quite warm at full drive, but not so hot that you can't touch them without being burned.*

a. Connect 50 ohm dummy load to phono jack J1 through some form of vhf wattmeter suitable to measure up to 5W.

b. Check output voltage of power supply, adjust it to 13.6 Vdc, and connect it to B+ terminal E1 and ground terminal E3 on the pc board. It is permissible to use the braid of the coax cable or the mounting hardware to the chassis as a ground if the power supply has a good low-resistance connection through this path to the ground on the board.

CAUTION: *Be sure to observe polarity to avoid damage to transistors!*

A 1000 mA meter or suitable equivalent should be connected in the B+ line to monitor current drawn by the exciter. This is important to indicate potential trouble before it can overheat transistors. Better yet, if using a lab supply for testing, set the current limiter on

Device	Frequency Weight
Jumper E6-E7	5.120 MHz
Switch #1	2.560 MHz
Switch #2	1.280 MHz
Switch #3	640 kHz
Switch #4	320 kHz
Switch #5	160 kHz
Switch #6	80 kHz
Switch #7	40 kHz
Switch #8	20 kHz
Switch #9	10 kHz
Switch #10	5 kHz

the power supply to limit at 700 mA.

Note: Meter indications used as references are typical but may vary widely due to many factors not related to performance, such as type of meter and circuit tolerances. Typical test point indications are for the 144 MHz band unit and may differ for other bands.

- c. Set dip switch for desired frequency.
- d. Connect voltmeter to TP1 (top lead of R6). Adjust vco coil L1 for +2Vdc. (Although the vco will operate over a wide range of tuning voltages from about 1V to 5V, operation is optimum if the vco is adjusted to 2V.)
- e. Connect voltmeter to TP2. Adjust buffer coils L3 and L4 alternately for a peak, typically about +0.3V.
- f. Alternately, adjust driver coil L5, PA input coil L8, and PA output capacitor C44 for maximum output. Note that coil tuning may be very broad. There may be small interactions between tuning controls, so repeat until no more interactions are noticed.
- g. At full drive, the total current drawn by the exciter should be 400-600 mA, and the RF output should be about 2 to 4W. Maximum output obtainable varies with many factors, so don't worry if it is a little lower or higher than expected.

Note that full output may not be possible when operating on a power supply less than 13.6 Vdc. Power output falls rapidly as operating voltage is reduced. For example, on a sample 144MHz unit, output level of 3.3W at 13.6Vdc was reduced to 2W output at 10Vdc.

This does not necessarily mean that the unit cannot be used on lower B+ voltage, however, since it is hard to distinguish even a 2:1 reduction in power on the air. And sometimes, you may wish to deliberately restrain the output level to be conservative. Reducing the power supply voltage is a good way to do it. Just don't operate below 10Vdc because the voltage regulators would fall out of regulation with too low an input. And do not reduce voltage by putting resistance in series with the supply; you want a well regulated/filtered power source.

After tuning the exciter into a known good 50 ohm dummy load, it should not be retuned when later connected to the antenna or power amplifier. Of course, the antenna or pa should present a good 50 ohm load to the exciter.

h. Perform the carrier frequency and audio level adjustments given on page 2 to complete the alignment of the exciter.

THEORY OF OPERATION.

The T301 is a frequency synthesized vhf fm exciter. The carrier frequency is generated by voltage controlled oscillator Q1. The output is buffered by Q2 to minimize effects of loading and voltage variations of following stages from modulating the carrier frequency. The resultant signal is amplified in successive stages to provide 2 to 4 Watts output into a

50Ω load.

The frequency of the vco stage is controlled by phase locked loop synthesizer U2. A sample of the vco output is applied through the buffer stage and R1 to a prescaler in U2. The prescaler and other dividers in the synthesizer divide the sample down to 5kHz.

A reference frequency of 10.240 MHz is generated by a TCXO (temperature compensated crystal oscillator). The reference is divided down to 5 kHz.

The two 5kHz signals are compared to determine what error exists between them. The result is a slowly varying dc tuning voltage used to phase lock the vco precisely onto the desired channel frequency.

The tuning voltage is applied to carrier tune varactor diode D1, which varies its capacitance to tune the tank circuit formed by L1/C20/C21. C16 limits the tuning range of D1. The tuning voltage is applied to D1 through a third order low pass loop filter, which removes the 5kHz reference frequency from the tuning voltage to avoid whine.

Modulation is applied to the loop filter at R19. Audio or data signals are amplified by U5a, limited by D4/D5, and applied to R19 through low pass filter U5b. The first op amp, U5a, provides pre-emphasis so that higher audio frequencies deviate wider than lower frequencies. The second op amp, U5b, provides a 12dB/octave rolloff for any audio or data modulation products over 3000 Hz to prevent splatter interference to other nearby channels. A direct modulation input is provided through E5 and R37 for use with a subaudible tone (CTCSS) encoder.

A lock detector in the synthesizer ic provides an indication of when the synthesizer is properly locked on frequency. In order for it to lock, the vco must be tuned to allow it to generate the proper frequency within the range of voltages the phase detector in the synthesizer can generate, roughly 1Vdc to 5Vdc. If the vco does not generate the proper frequency to allow the synthesizer to lock, the lock detector output turns off U5c, which provides operating bias to the pre-driver amplifier, thus preventing the exciter from putting out signals which are off frequency. This feature ensures that the signal will reach the antenna only after the carrier locks on frequency.

Serial data to indicate the desired channel frequency and other operational characteristics of the synthesizer are applied to synthesizer U2 by microcontroller U1. Everything the synthesizer needs to know about the band, division schemes, reference frequency, and oscillator options is generated by the controller. Information about the base frequency of the band the T301 is to operate on and the channel within that band is calculated in the controller based on information programmed in the eeprom on the controller and on channel

settings done on dip switch S1 and jumper E6-E7. When the microcontroller boots at power up, it sends several bytes of serial data to the synthesizer, using the data, clock, and /enable lines running between the two ic's.

+13.6Vdc power for the exciter is applied at E1. This B+ input is keyed on and off to control when the exciter transmits a signal. There is a jumper trace under the board running to E4, which allows power to be applied constantly to the synthesizer circuits if desired. This is convenient for applications where the exciter will be keyed on and off regularly. Because the microcontroller must boot before it can send data to the synthesizer, there is a short delay in generating the carrier when power is first applied to the synthesizer circuits.

RF amplifier stages are powered directly by the +13.6Vdc. However, all the lower level stages are powered through voltage regulators for stability and to eliminate noise. U4 is an 8Vdc regulator to power the vco, buffer, and phase detector in the synthesizer. Additional filtering for the vco and buffer stages is provided by capacitance amplifier Q3, which uses the characteristics of an emitter follower to provide a very stiff supply, eliminating any noise on the power supply line.

Resistive voltage dividers provide lower voltages which are regulated because they are based on the regulated 8Vdc from U4. U5d provides a stiff +5Vdc supply for the frequency synthesizer and microcontroller.

TROUBLESHOOTING.

General.

Checking dc voltages and signal tracing with an RF voltmeter probe and oscilloscope will work well in troubleshooting the T301. A dc voltage chart and a list of typical audio levels are given to act as a guide to troubleshooting. Although voltages may vary widely from set to set and under various operating and measurement conditions, the indications may be helpful when used in a logical troubleshooting procedure.

The exciter draws about 30 mA of current when just the synthesizer and audio circuits are operating. When the exciter is generating an RF output, it draws a total of about 450-600 mA.

RF Amplifier Circuits.

You can use an RF probe with a dc voltmeter or scope to check the relative RF levels at the input and output of each stage. The output level should always be higher than the input level of a given stage. Also, check the dc operating and bias voltages for each stage. The pre-driver stage gets its bias only when the lock detector in the synthesizer is locked; so if that bias is missing, check the synthesizer and vco to see why it isn't locked.

Synthesizer Circuits.

Following is a checklist of things to look for if the synthesizer is suspected of not performing properly.

- Check the output frequency of the vco buffer with a frequency counter.
- Check the lock detector at either pad of R25 with a dc voltmeter. (7Vdc locked, 0Vdc unlocked).
- Check tuning voltage at TP1. It should be about +2Vdc. Actual range over which the unit will operate is about +1Vdc to just under +5Vdc. However, for optimum results, the vco should be tuned to allow operation at about +2Vdc center voltage.
- Check the operating voltage and bias on the vco and buffer.
- Check the amplified 10.240 MHz TCXO signal at pin 1 of the synthesizer ic. Be very careful not to short adjacent pins of the ic. A scope should show several volts p-p at 10.240 MHz.
- Check the oscillator at pin 1 of micro-controller ic U1 with a scope. There should be a strong ac signal (several volts p-p) at the oscillator frequency.
- The data, clock, and /enable lines between the microcontroller and synthesizer ic's should show very brief and fast activity, sending data to the synthesizer ic shortly after the power is first applied or a dip switch setting is changed. Because this happens very fast, it can be difficult to see on a scope. Use 100µSec/div, 5Vdc/div, and NORMAL trigger.
- Check the microcontroller to see that its /reset line is held low momentarily when the power is first applied. C1 works in conjunction with an internal resistor and diode in the ic to make C1 charge relatively slowly when the power is applied. It should take about a second to charge up.
- Check dipswitch and E6-E7 jumper settings to be sure you have the correct frequency information going to the microcontroller.

Audio.

You can check the following levels with a scope.

- The audio input must be 40mV p-p or greater at input E2 for full 5kHz deviation.
- Gain control R26 sets the gain of amplifier U5a. Provided enough gain and audio input, the limiter output will provide about 1V p-p at the input of deviation pot R35.
- The output of active filter U5b is a maximum of about 2V p-p if the limiter is driven into limiting. This assumes a test signal at about 1000 Hz. This ac signal should be riding on a dc center voltage of about +4.4Vdc. That is what should be applied to the modulator diode through R42.
- You can also check for the presence of the proper dc voltages on the op amps, which use bias voltages of +4Vdc and +2.2Vdc. Refer to the power supply circuits on the sche-

matic diagram.

Microphonics, Hum, and Noise.

The vco and loop filter are very sensitive to hum and noise pickup from magnetic and electrical sources. Some designs use a shielded compartment for vco's. We assume the whole board will be installed in a shielded enclosure; so we elected to keep the size small by not using a separate shield on the vco. However, this means that you must use care to keep wiring away from the vco circuit at the right side of the board. Having the board in a metal enclosure will shield these sensitive circuits from florescent lights and other strong sources of noise.

Because the frequency of a synthesizer basically results from a free running L-C oscillator, the tank circuit, especially L1, is very sensitive to microphonics from mechanical noise coupled to the coil. You should minimize any sources of vibration which might be coupled to the exciter, such as motors.

Excessive noise on the dc power supply which operates the exciter can cause noise to modulate the signal. Various regulators and filters in the exciter are designed to minimize sensitivity to wiring noise. However, in extreme cases, such as in mobile installations with alternator whine, you may need to add extra filtering in the power line to prevent the noise from reaching the exciter.

Other usual practices for mobile installations are recommended, such as tying the + power and ground return lines directly to the battery instead of using cigarette lighter sockets or dash board wiring.

To varying degrees, whine from the 5kHz reference frequency can be heard on the signal under various circumstances. If the tuning voltage required to tune the vco on frequency is very high or low, near one extreme, the whine may be heard. This can also happen even when the tuning voltage is properly near the 2Vdc center if there is dc loading on the loop filter. Any current loading, no matter how small, on the loop filter causes the phase detector to pump harder to maintain the tuning voltage. The result is whine on the signal. Such loading can be caused by connecting a voltmeter to TP1 for testing, and it can also be caused by moisture on the loop filter components.

Typical Dc Voltages.

The following dc levels were measured with a sensitive dc voltmeter on a sample unit with 13.6 Vdc B+ applied. All voltages may vary considerably without necessarily indicating trouble. The chart should be used with a logical troubleshooting plan. All voltages are positive with respect to ground except as indicated. Voltages are measured with the exciter operating and fully tuned to provide normal output. Note that meter probe must have a 10 megΩ or similar resistor in probe to

Table 3. Typical Test Point Voltages

TP1	Normally set at 2V
TP2	Roughly 0.3V
Note: These can vary considerably without necessarily indicating a problem.	

Table 4. Typical Xstr DC Voltages

STAGE	E	B	C
Q1 vco	1.5	2.2	7.2
Q2 buffer	0	0.75	5
Q3 dc filter	7.2	7.8	8
Q4 pre-driver	0.3	0.3	13.6
Q5 driver	0	0.2	13.6
Q6 pwr ampl	0	0	13.6
Limiter R33		0.43	
Limiter R34/diodes		1	
Limiter R35		0.43	

Figure 5. Typical IC DC Voltages

U1-1	4	U1-2	4
U2-1	2.7	U2-10	2.7
U2-2	5v locked	U2-11	2.7
	(pulses unlocked)	U2-12	5
U2-3	5 *	U2-13	3.3 *
U2-4	5 *	U2-14	5
U2-5	5	U2-15	*
U2-6	0-5 (2V tuned)	U2-16	*
U2-7	0	U2-17	5
U2-8	4.8	U2-18	0
U2-9	5 *	U2-19	0
	* = pin not used	U2-20	2.7
U5-1	4	U5-8	7
U5-2	4.5	U5-9	4
U5-3	4	U5-10	4.7
U5-4	8	U5-11	0
U5-5	2.2	U5-12	5
U5-6	2.4	U5-13	5
U5-7	4.5	U5-14	5

Table 6. Typical Audio Voltages

Test Point	mV p-p
E2 AF input	40(min)
U5-1	1000
D5 cathode	1000
U5-7	2000

isolate from RF signals. Even then, the type of meter and probe has an effect on the readings taken on points where RF is present.

Use caution when measuring voltages on the surface mount ic. The pins are close together, and it is easy to short pins together and damage the ic. We recommend trying to connect meter to a nearby component connected to the pin under question. Also, some pins are not used in this design, and you can generally not be concerned with making measurements on them.

Typical Audio Voltages.

Table 6 gives rough measurements of audio voltages which may be measured with a sensitive voltmeter or an oscilloscope when an audio source with a tone about 1000 Hz is connected and modulating to full 5 kHz deviation. Measurements given were taken with an oscilloscope with audio gain and deviation controls fully cw and sufficient audio input applied for full deviation of the RF signal. Measurements are typical of what might be

indicated during a sustained whistle or with an audio signal generator. Of course, readings may vary widely with setup; but levels given are useful as a general guide.

REPAIRS.

If you need to unsolder and replace any components, be careful not to damage the plated through holes on the pc board. Do not drill out any holes. If you need to remove solder, use a solder sucker or solder wick. A toothpick or dental probe can be used with care to open up a hole.

If you need to replace a surface mount ic, first be very sure it is damaged. Then, care-

fully cut each lead off the case with fine nose cutters. Once the case is removed, individual leads can be unsoldered and the board can be cleaned up. Carefully position the new ic, and tack solder the two opposite corner leads before any other leads are soldered. This allows you to melt the solder and reposition the ic if necessary. Once you are sure, the remaining leads can be soldered. If you get a solder short between leads, use a solder sucker or solder wick to remove the excess solder.

If it becomes necessary to replace output transistor Q6, you must unsolder the three leads first from under the board. Then, carefully melt the solder holding the can to the top

of the board. This requires a very hot iron or a hot air tool, and care must be taken to avoid damaging the board. Once the transistor is removed, a vacuum solder sucker can be used to clean the excess solder off the ground plane. Install the new output transistor flat against the board, and solder the leads on the bottom of the board. Then, solder the bottom of the metal can to the pcb ground plane with a continuous bead of solder flowing around the can. (Soldering the can to the ground plane is necessary to provide a low impedance emitter ground and heatsinking; the transistor is designed to be installed this way).

PARTS LIST FOR T301 EXCITER, REV F.

Note: Values which vary with freq. band are shown in a table at the end of the parts list. Parts on bottom of board are 0805 or 0603 surface mount parts.

Following are notes specific to certain parts.

❶ Remove tuning slugs from coils L9-L11 in the output of the PA stage.

❷ Microcontroller must be factory programmed for proper band segment and for TCXO or crystal osc option.

⚠ Caution: IC's are static sensitive. Use appropriate handling precautions to avoid damage.

Ref Desig	Value (marking)
C1	1 µf electrolytic
C2	0.1µf
C3	220pf
C4	100µf electrolytic
C5-C7	not assigned
C9	0.1µf
C10	0.15µf mylar (red)
C11	.01µf
C12	.001µf
C13	0.1µf
C14	100µf electrolytic
C15	0.1µf
C19	100µf electrolytic
C22	4pf
C26	not assigned
C27	0.1µf
C28	100µf electrolytic
C29	100µf electrolytic
C30	not assigned
C43	0.1µf
C47	1µf electrolytic
C49	.033µf
C50	100µf electrolytic
C51	4.7µf electrolytic
C52	1µf electrolytic
C53-C54	.0033µf
C55-C56	220pf
C58	100µf electrolytic
D1	BB132 varactor diode
D2-D3	not assigned
D4-D5	1N4148
J1	RCA Jack
L2	0.33µH RF choke (red-sil-orn-orn)
L3-L5	2½ t., slug tuned (red)
L8	2½ t., slug tuned (red)
L9-L11 ❶	2½ t., NO SLUG (red)

Q1	2N5770
Q2	MPS5179
Q3	MMBT3904
Q4	PN5179
Q6	MRF-237
R1	180Ω
R2	2meg
R3	not assigned
R4-R5	15K
R6	100K
R7	1 meg
R8	2.2K
R9	10K
R10	6.8K
R11	3.9K
R12	180Ω
R13	47Ω
R14	47K
R15	470Ω
R16	not assigned
R17	6.8K
R18	2.2K
R19	100Ω
R20	15K
R21	2.2K
R23	not used
R25	470Ω
R26	1K trim pot. (102)
R27	47K
R28	1K
R29	150K
R30	3.9K
R31	4.7K
R32	2.2K
R33	1K
R34	10K
R35	1K trim pot. (102)
R36	47K
R37	10K
R38-R39	15K
R40-R41	47K
R42	3.9K
R43	27Ω
R44	100Ω
R45-R46	27Ω
S1	10 pos. DIP switch
U1 ❷	MC68HC705J1A µP
U2 ❷	MC145191F synthesizer
U3 ❷	10.240MHz TCXO (option)
U4	78L08ACD (smt) regulator
U5	LM324D (smt) op amp
Z1-Z4	Ferrite bead, prestrung

VALUES WHICH VARY WITH FREQUENCY BAND:

T301-2 is 144.000 - 154.235 MHz
T301-3 is 154.200 - 164.435 MHz
T301-4 is 164.400 - 174.635 MHz
T301-5 is 216.000 - 226.235 MHz
T301-6 is 220.000 - 230.235 MHz

Ref Desig	-2	-3	-4	-5/-6
C16	10	8	7	7
C20	12	10	8	10
C21	47	43	30	47
C24	33	27	27	10
C25	47	39	33	18
C31	8	7	6	6
C32	33	27	27	12
C33	47	39	33	18
C36	30	22	18	7
C37	47	39	27	n/u
C39	8	8	8	2
C40	22	18	15	6
C44	50pf var. (brn)	50pf var. (brn)	50pf var. (brn)	30pf var. (grn)
C45, C46	18	15	12	4
C59, C60	15	12	10	8
L1 ❸	2½T (red)	2½T (red)	2½T (red)	1½T
L6, L7	0.33µH	0.33µH	0.33µH	0.22µH
Q5	2N5770	2N5770	MPS 5179*	MPS 5179*
R22	10Ω	10Ω	10Ω	47Ω
R24	47Ω	47Ω	47Ω	100Ω

* Caution: MPS5179 has different pin out from PN5179.

Bypass capacitors C8, C17, C18, C23, C34, C35, C38, C41, C42, C48, C57 are 390pf for T301-2, -3, and -4 and 220pf for -5 and -6

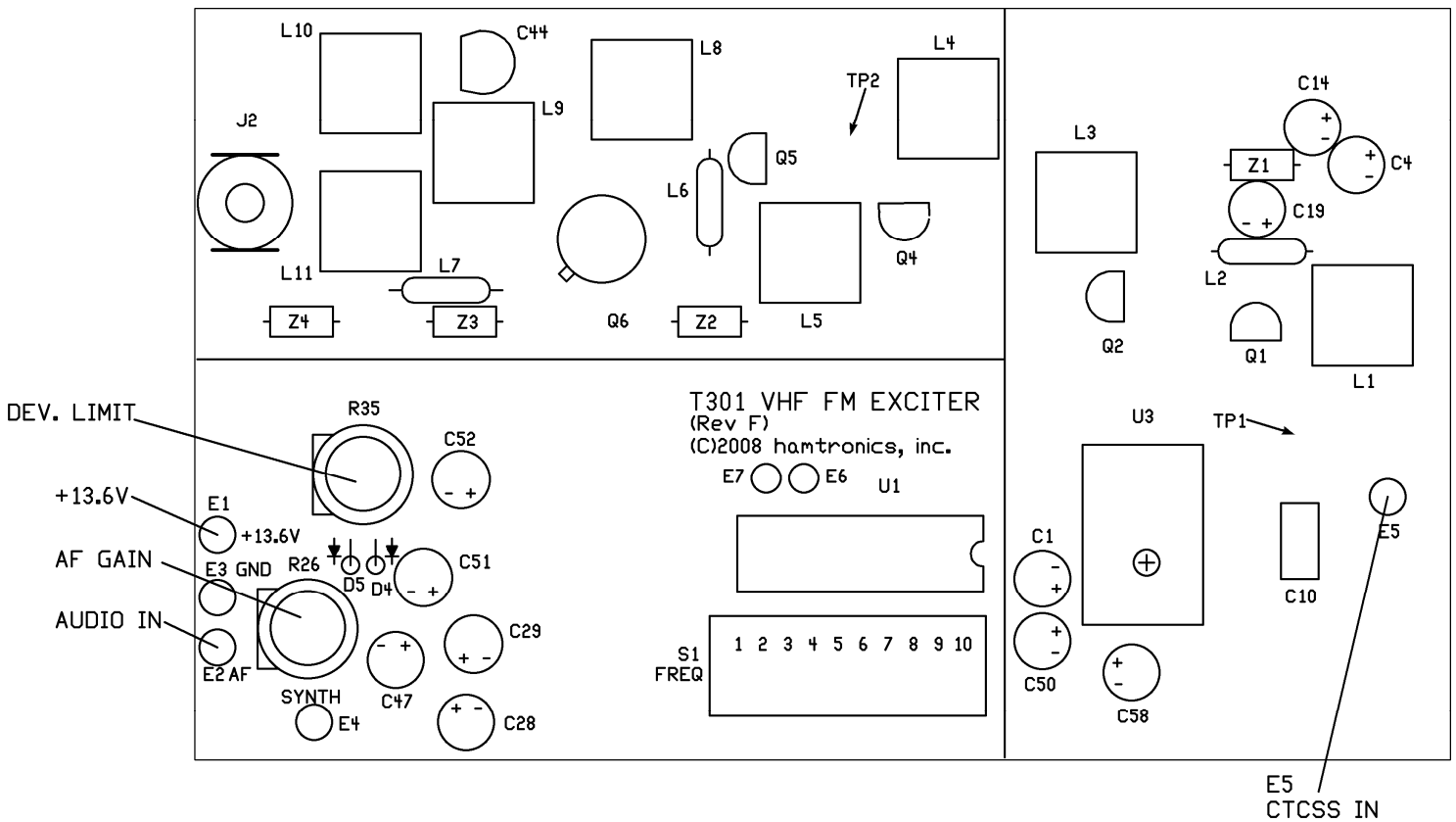
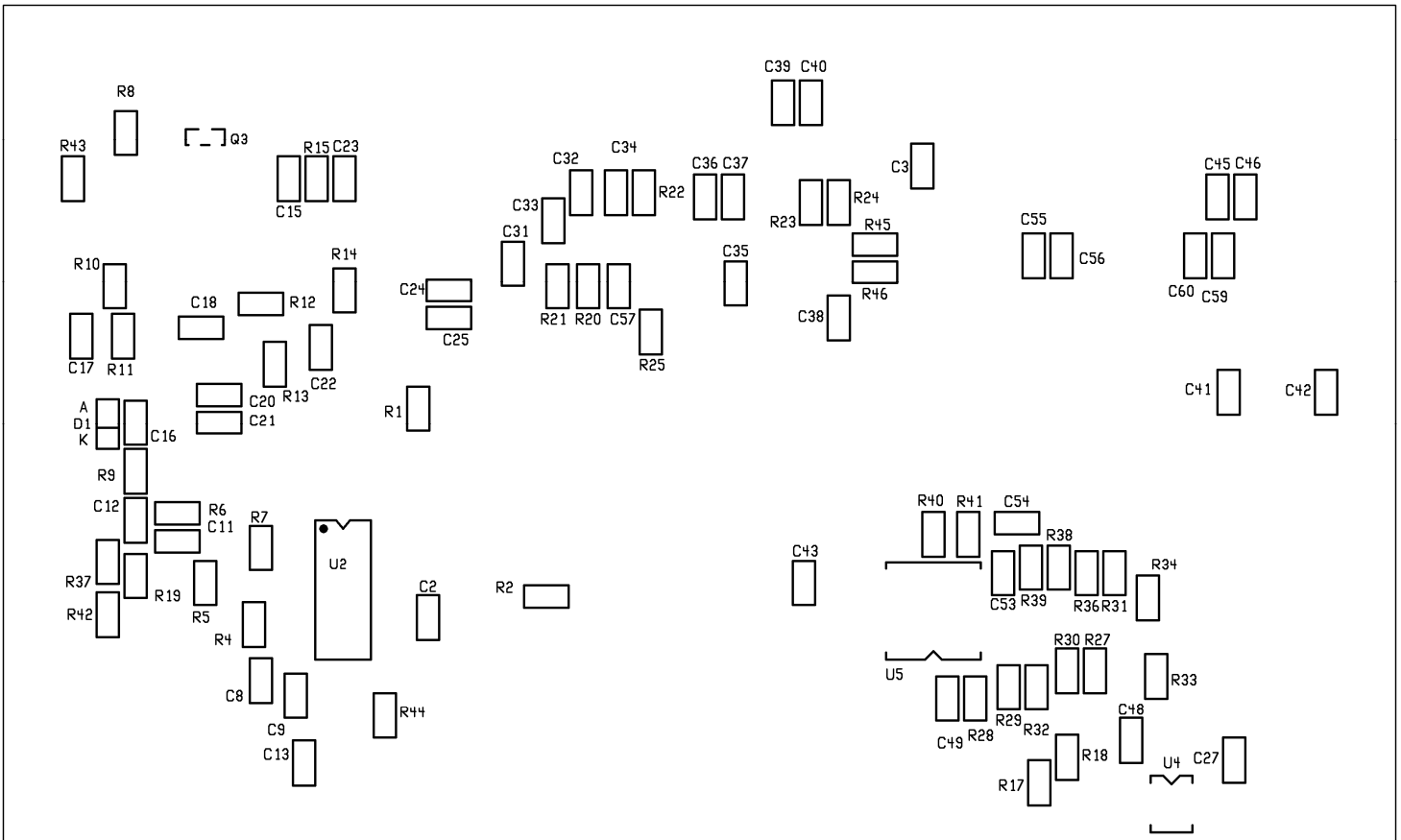

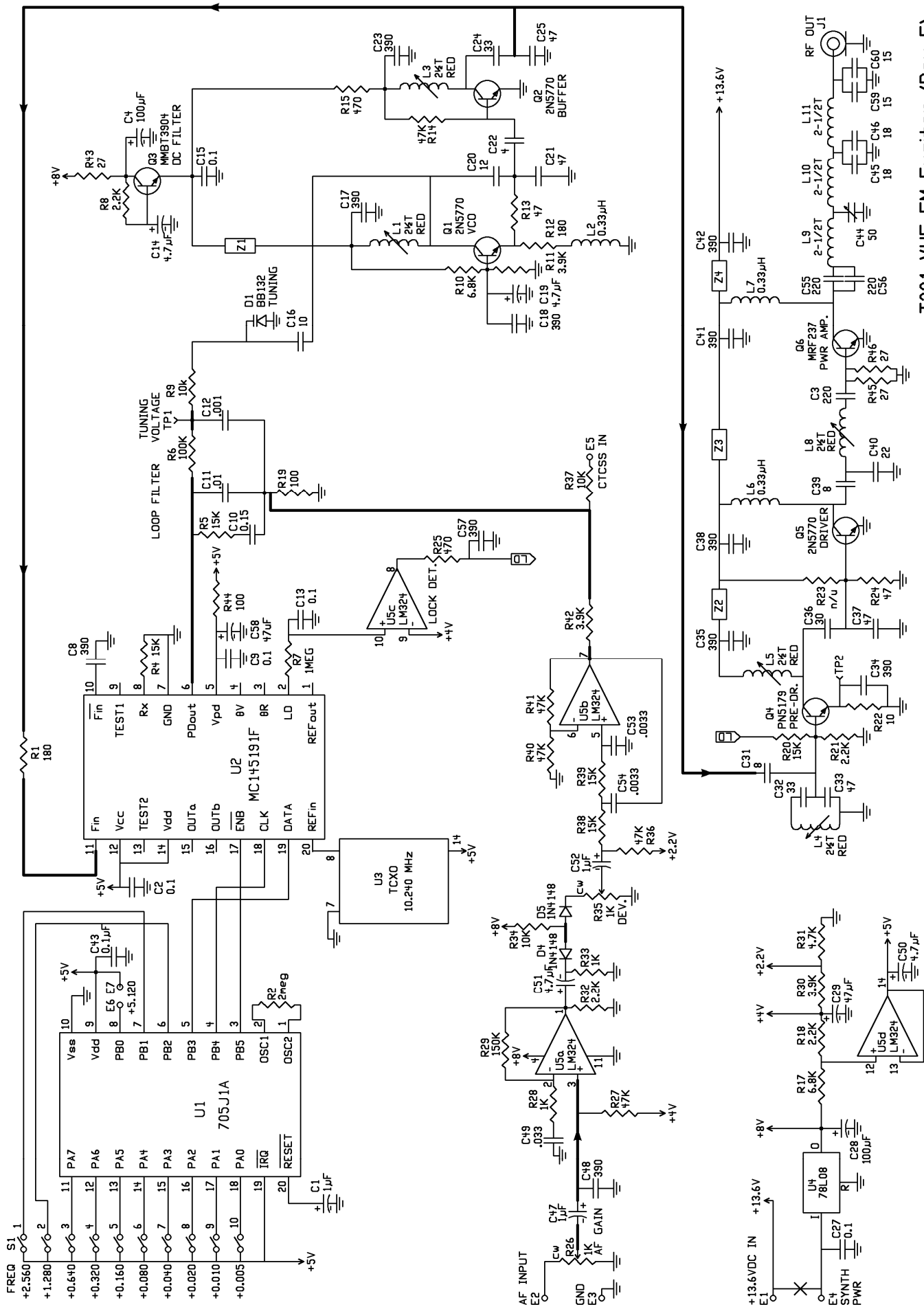

T301 VHF FM Exciter (Rev F)
 Values shown are for 144MHz band. For other bands, see part list.