

HAMTRONICS® TA51 (REV A) VHF FM EXCITER: INSTALLATION, OPERATION, & MAINTENANCE

GENERAL INFORMATION.

The TA51-144 is a single-channel vhf fm exciter designed to provide 2 to 3 Watts continuous duty output into a 50 ohm antenna system in the 144 MHz ham band or the 148-175 MHz commercial band. The TA51-220 is a similar model to cover the 213-233 MHz ham and government bands. (There is a TA51-50, which covers the 50-54 MHz ham band, and a TA51-72, which covers 72-76 MHz; however, these models use a different pc board and have a different manual.)

They are designed for narrow-band fm with 5 kHz deviation. Audio input is designed to accept a standard low-impedance dynamic microphone or any low-impedance audio source capable of providing 30mV p-p into a 2K load. Operating power is +13.6 Vdc +/-10% at 500-700 mA.

The sequence of presentation of the following information assumes that you purchased a wired exciter, ready to operate. If you purchased a kit, refer to page 2 for Alignment instructions prior to performing audio level or frequency adjustments.

ASSEMBLY.

Note: This manual pertains only to high band and 220MHz units with the green pc board. There is a separate manual for low band units, which use a silver colored pc board.

Refer to the component location diagram and the parts list during assembly. Following is a general guideline for the sequence of assembly and notes on items to give special attention.

a. Install the two crystal sockets. Cut them from the metal carrier strip. Install from top of board, and rock them while pressing into holes. They will snap in place when fully seated. Solder lightly to avoid wicking solder up into top of pins.

b. Install two potentiometers, R3 and R20.

c. Install IC socket with notch at end indicated for pins 1 and 14. Then plug in IC U1, being careful not to bend over any of the pins.

d. Install transistors Q1-Q7 as low as possible for short leads.

e. Install rf output transistor Q8 flat against the board, and solder the leads on the bottom of the board.

Then, solder the bottom of Q8's metal can to the pcb ground plane with three small solder tacks around the base of the transistor. *Soldering the can to the ground plane is necessary to provide heatsinking and a low impedance emitter ground; the transistor is designed to be installed this way. Just be careful not to use a lot of solder, because it could flow under the transistor and short out the base or collector lead. Note that the output transistor is mismarked on the pc board as "Q1".*

f. Slide a heatsink over the metal case of Q8. Note that no heatsink compound is required.

g. Install phono jack J1. For the shortest rf path, orient the jack with the center terminal toward the upper-left (toward the output coils). Solder all lugs under the board.

h. Install variable capacitors, orienting as shown so rotors are connected to ground.

i. Install electrolytic capacitors, observing polarity.

j. Install ceramic capacitors. It may be necessary to form capacitor leads to fit holes in board. Keep leads as short as possible. Note that values over 100 pf are marked with two significant figures and a multiplier, much as resistors are marked but with numbers. The parts list gives the markings on such parts.

k. Neither C63 nor the jumper wire next to C63 are normally used. They are used only for the TCXO option, which is rarely used. Just omit them.

l. Install all other resistors. On vertical parts, form top lead directly over for shortest leads. The circle on the location diagram indicates where the body of the part should be. For resistors used as test points (TP1-TP4), form as shown in the detail drawing at the top of the component location diagram to leave a small test point loop for connection of a meter probe. Be careful not to mix resistors which look similar, i.e., 150K and 510K.

m. Install two 1N4148 diodes, CR1 and CR2, and zener diode, VR1, observing polarity. The polarity is indicated by a schematic symbol on the component location diagram.

n. Install rf chokes.

o. Ferrite beads Z1-Z9 are supplied with wire leads already attached. Install them as shown.

p. Install slug tuned coils as shown. Install coil shields. The 2-1-2 turn (red) coils come with shields already on the coils. The 6-1-2 turn (blue) coils have shields supplied separately. Make sure the coils and shields are fully seated, and solder both shield lugs. (Do not bend lugs over, but you can bend the coil leads over a little to hold them in place while soldering.)

q. Remove the slugs from coils L10, L12, L13, and L14, and save them for spares. The coils of the driver and pa stages are not tuned with slugs because of the higher power levels. The slugs have a square slot. Refer to the note about tuning tools in the *Alignment* instructions on page 2 of the *Installation, Operation, and Maintenance Manual*.

r. Turn the board over, and install R47 on the rear of the board, using very short leads. Cut the leads to 1/16 inch and tack solder the resistor directly across the leads of slug-tuned coil L3. The resistor should just fit in a straight line between the two leads of the coil.

s. Check over all components and solder connections before proceeding to alignment procedures. If you are short any parts, check to see if any are left over; you may have installed a wrong value somewhere. Check to be sure that Q8 is not touching the pc board ground plane and that there are no slugs in L10 and L12-L14.

CRYSTALS.

The TA51 uses 32 pF parallel resonant crystals in HC-25/u holders. Crystals operate in the fundamental mode at a frequency of:

- F/12 for TA51-144
- F/18 for TA51-220

This normally results in a crystal frequency in the 12-13 MHz area.

We recommend that crystals be ordered directly from us to be sure that they will perform properly over the -30 to +60°C range for which the unit was designed. If you buy crystals elsewhere, make sure you get only the highest quality commercial grade crystals to avoid problems later on.

If you use an OV-1 crystal oven, specify a crystal with a 60°C break-point. The crystal is inserted into sockets on the board. The oven is installed on the board over the crystal, observing polarity by matching the

3-lead pattern to the holes in the board (see component location diagram). Then, the pins of the oven are soldered to the board.

POWER.

The TA51 Exciter operates on +13.6Vdc at about 500-700 mA. A well regulated power supply should be used. Positive and negative power leads should be connected to the exciter at E1 and E3. Be sure to observe polarity. If a crystal oven is used, +13.6Vdc should be connected to the oven via E4 from a supply line separate from E1, since E1 is keyed on and off to transmit. Oven power should remain on constantly during any period when transmission is expected.

MOUNTING.

The four mounting holes provided near the corners of the board can be used in conjunction with screws and standoffs to mount the board in any cabinet or panel arrangement. (See catalog for A26 PC Mounting Kits.) There is no need for a shielded cabinet except if the exciter is used in a repeater or in duplex service.

KEYING.

The easiest way to key the exciter is to run the B+ for the unit (E1) through the push-to-talk switch in the microphone or a similar spst switch. Although a relay may be used, it is not necessary; since the 500-700 mA required by the exciter may easily be switched by most microphone switches. If you are interfacing with some sort of control board, a PNP transistor, such as a TIP-30, can be used to switch the current to operate the exciter. If a class-C power amplifier is driven by the exciter, the pa will draw current only when the TA51 exciter is driving it with rf power; so the pa should not require a separate keyline circuit.

AUDIO CONNECTIONS.

The TA51 Exciter is designed for use with a low impedance dynamic microphone (500-1000 ohms) or any low impedance audio source capable of supplying 30 mV p-p across 2000 ohms. The microphone should be connected with shielded cable to avoid noise pickup. Mic connections are made to E2 and E3 on the pc board. *Be sure to dress the audio cable away from the piston capacitor; since close proximity could affect channel frequency.*

AUDIO DEVIATION ADJUSTMENTS.

To adjust the audio controls, start by setting potentiometer R20 to maximum and R3 to midrange. Apply B+ to E1 to key the exciter and talk into the microphone or apply audio of normal expected level to the exciter. If the unit is setup with tones from a service monitor, use a tone frequency of 1000 Hz. Observe the deviation meter or the scope on a service monitor, and adjust R20 for a peak deviation of 5 kHz. Then, adjust mic gain control R3 so that the exciter deviation just swings up to 5 kHz on modulation peaks.

This will provide the optimum setting, with sufficient audio gain to achieve full modulation but with the limiter occasionally clipping voice peaks to prevent over-modulation. Avoid setting the audio gain higher than necessary. Although the deviation limiter will prevent over-modulation, microphone background noise is increased and some distortion from excessive clipping may result.

Note that when the exciter is used in repeater service, instructions in the manuals for the COR and Autopatch modules should be used to set the exciter audio controls, since each repeater system requires a specific audio adjustment method.

FREQUENCY ADJUSTMENT.

The crystal frequency is precisely set on the channel frequency with piston trimmer capacitor C13, using an accurate service monitor or frequency counter.

Note that the tuning range of piston capacitor C13 was deliberately limited to provide optimum frequency stability. With some crystals, the frequency may not be adjustable high enough. If this is the case, clip the jumper to disconnect C63 from the circuit, which raises the frequency range of the variable capacitor.

SUBAUDIBLE TONES.

If you want to transmit a CTCSS (subaudible) tone, you can connect the output of the tone encoder through a 10K resistor directly to the audio input of the exciter. (Our TD-3 Tone Decoder/Encoder module already has a resistor on board; so it does not require an extra resistor.) If you prefer to inject the CTCSS tone after the audio circuits in the exciter, you can inject it through a large resistor into the junction of R21 and R22. The level of the subaudible tone

should be set no higher than about 300 Hz deviation for best results. Otherwise, a buzz may be heard on the audio at the receiver.

THEORY OF OPERATION.

The TA51 is a fairly straight forward fm exciter, with a phase modulated 12 MHz signal multiplied up to reach the desired output range. Crystal oscillator Q1 operates as a Colpitts oscillator at the fundamental frequency of approximately 12 MHz. When supplied with TCXO option, a thermistor compensates for cold temperatures by gradually reducing the amount of load capacitance in series with the crystal at temperatures below +10 degrees C. The oscillator output is fed into reactance modulator Q2, which phase modulates the carrier with audio from the speech processor circuits.

For the 144 MHz ham band or the high commercial band, Q3 operates as a tripler to multiply the carrier frequency to a range of about 36 MHz. Q4 doubles this to arrange of about 72 MHz. This, in turn, is doubled again in Q5 to range of about 144 MHz, which is the final output frequency.

For the 220 MHz band, Q3 operates as a tripler to multiply the carrier frequency to a range of about 36 MHz. Q4 triples this again to arrange of about 110 MHz. This, in turn, is doubled in Q5 to range of about 220 MHz.

Q6 acts as a predriver amplifier. The signal is further amplified by driver Q7 and output amplifier Q8 to provide the 2 Watt output signal to the 50 ohm antenna. Spurious signal rejection is provided by double tuned circuits between multiplier stages and two low pass filters in the output of the pa stage.

The audio processor circuits consist of microphone amplifier U1-A and U1-B, peak limiter CR1-CR2, amplifier U1-D, and active filter U1-C. The audio input, at a level of about 30 mV p-p, is amplified and applied to the limiter circuit. R3 provides adjustment of the audio gain of the first op-amp. Processed audio, limited in peak amplitude, contains a small amount of harmonic distortion from the clipping process. Active filter U1-C is a low pass filter which greatly reduces the effects of any distortion from the limiter to prevent splatter of sidebands outside the bandwidth allowed for one channel. Deviation potentiometer R20 allows for adjustment of the peak audio level applied to

modulator Q2. C11-R23 is an rf filter to keep the 12 MHz carrier signal from getting back into the active filter stage. R21-C10-R22-C11 acts as an additional low pass filter. Together with the active filter stage, it provides a 12 dB/octave rolloff for any frequencies over 3000 Hz.

Dc power for the exciter is applied at E1 when the unit is required to transmit. +13.6 Vdc is applied to all stages, except the oscillator, modulator, and audio stages. A 9.1 Vdc regulator provides power for those stages for stability of the carrier frequency under varying input voltages and for noise and hum filtering. Power supplied through R45 is regulated by zener diode VR1 and filtered by C60 to isolate the sensitive stages from the outside world.

ALIGNMENT.

Equipment needed for alignment is a voltmeter, a good uhf 50 ohm rf dummy load, a relative output meter, and a regulated 13.6Vdc power supply with a 0-1000 mA meter internally or externally connected in the supply line.

The slug tuned coils in the exciter should be adjusted with the proper .062" square tuning tool to avoid cracking the powdered iron slugs. (See A28 tool in catalog.) All variable capacitors should be set to the center of their range (turn them 90 degrees) if they have not previously been aligned.

⊗ **NOTE:** *Following are some ground rules to help avoid trouble. Always adhere to these guidelines.*

1. Do not operate without a 50 ohm load.

2. Always follow alignment procedure exactly. Do not repeak all controls for maximum output. Each multiplier stage has its own best monitoring test point for maximum drive to the following stage.

3. Rf power transistors Q7 and Q8 run quite warm at full drive, but not so hot that you can't touch them without being burned.

a. Connect 50 ohm dummy load to phono jack J1 through some form of relative output meter.

b. Check output voltage of power supply, adjust it to 13.6 Vdc, and connect it to B+ terminal E1 and ground terminal E3 on the pc board. It is permissible to use the braid of the coax cable or the mounting hardware to the chassis as a ground if the power supply has a good low-impedance connection through this path to the ground

on the board. **BE SURE TO OBSERVE POLARITY!** A 1000 mA meter or suitable equivalent should be connected in the B+ line to monitor current drawn by the exciter. This is important to indicate potential trouble before it can overheat transistors. Better yet, if using a lab supply for testing, set the current limiter on the power supply to limit at 750 mA.

Note: Meter indications used as references are typical but may vary widely due to many factors not related to performance, such as type of meter and circuit tolerances. Typical test point indications are for the 144 MHz or high band unit and may differ for other bands.

c. Connect voltmeter to TP2 (top lead of R35). Peak L2 and L3 alternately for maximum indication. Typical reading is about +0.8 to 1.2 Vdc.

d. Connect voltmeter to TP3 (top lead of R37). Peak L4 and L5 alternately for maximum indication. Typical reading is about +0.8 to 1.2 Vdc.

e. Connect voltmeter to TP4 (top lead of R40). Peak L6 and L7 alternately for maximum indication. Typical reading is about +0.4 to 0.9 Vdc.

f. At this point, you should have a small indication on the relative power meter. Alternately peak L8, C51, C53, and C56 for maximum indication on the power meter. Note that there are interactions between these adjustments, especially between tune capacitor C53 and loading capacitor C56; so it may be necessary to try several combinations to find the optimum settings. When peaking C53 and C56, it helps to observe dc current drain to find adjustment combination giving maximum output with minimum current drain (best efficiency).

g. At full drive, the total current drawn by the exciter should be 500-700 mA, and the rf output should be about 2 to 3.5 Watts.

Note that full output may not be possible with less than 13.6 Vdc B+. Power output falls rapidly as operating voltage is reduced. This does not necessarily mean that the unit cannot be used on lower B+ voltage, however, since it is hard to distinguish even a 2:1 reduction in power on the air.

After tuning the exciter into a known good 50 ohm dummy load, it should not be retuned when later connected to the antenna or power amplifier. Of course, the antenna or pa should present a good 50 ohm load to the exciter.

h. Perform the carrier frequency and audio level adjustments given on

page 1 to complete the alignment of the exciter.

Note: *If the audio sounds raspy, the first multiplier stage may be out of alignment; try repeaking L2 and L3 as described in step c.*

POWER ADJUSTMENT.

The drive level to the output stage can be adjusted somewhat by detuning L8, which will lower the power to about 1/2 without causing spurious outputs. If you need to reduce the level further, C51 can be detuned slightly to reduce the output to around 1/3 Watt. Note, however, that reducing the drive to a class-C amplifier can result in spurious signals if the drive is reduced too far. Other ways to reduce output without running this risk are to reduce the B+ voltage to around 11Vdc or using an attenuator after the exciter output.

TROUBLESHOOTING.

The usual troubleshooting techniques of checking dc voltages and signal tracing with an rf voltmeter probe will work well in troubleshooting the TA51. A dc voltage chart and a list of typical audio levels are given to act as a guide to troubleshooting. Although voltages may vary widely from set to set and under various operating and measurement conditions, the indications may be helpful when used in a logical troubleshooting procedure. The exciter should draw about 30-50 mA at idle, with the crystal pulled out, and about 500-700 mA at full output.

If you replace the output transistor for any reason, note that the metal can is soldered to the ground plane on the board for low inductance and for heatsinking. Do not attempt to operate without soldering the new transistor to the pcb foil.

TYPICAL DC VOLTAGES.

The following dc levels were measured with an 11 megohm fet vm on a sample unit with 13.6 Vdc B+ applied. All voltages may vary considerably without necessarily indicating trouble. The chart should be used with a logical troubleshooting plan. All voltages are positive with respect to ground except as indicated. Voltages are measured with crystal plugged in and oscillating and exciter fully tuned to provide full output. Note that meter probe must have 1 megohm or similar resistor in probe to isolate from rf signals. Even then, the type of meter and probe has an effect on the readings taken on points where rf is

present.

STAGE	E	B	C
Q1	3.7	3.0	8.5
Q2	2.3	3.0	5.5
Q3	0.9	1.5	13.6
Q4	0.9	-0.35	13.6
Q5	0.9	-1.4	13.6
Q6	0.6	-0.5	varies
Q7	0	-0.14	13.6
Q8	0	n/a	13.6
U1 pins 1,2,3,6,8,11,12,13:	0.55V		
U1 pins 4, 5, 9, 10:	4.6V		
U1 pin 14:	9.1V		

TYPICAL AUDIO VOLTAGES.

Following are rough measurements of audio voltages (in mV p-p) which

may be measured with a sensitive voltmeter or an oscilloscope when a low impedance dynamic microphone or other audio source is connected and modulating to full 5 kHz deviation. Measurements given were taken with an oscilloscope with mic gain and deviation controls fully cw and sufficient audio input applied for full deviation of the rf signal. Measurements are typical of what might be indicated during a sustained whistle or with an audio signal generator. Of course, readings may vary widely with setup; but levels given are useful as a gen-

eral guide. Note: if rf affects oscilloscope pattern, unplug crystal.

Test Point	mV p-p
E2 AF input	10
U1-4	50
U1-5	400
CR2 cathode at R12 top	400
U1-10	700
U1-9	1000
Top of R23	220

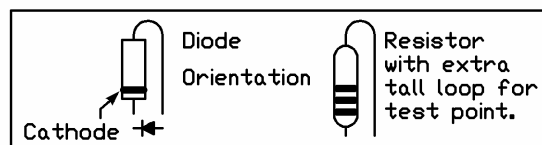
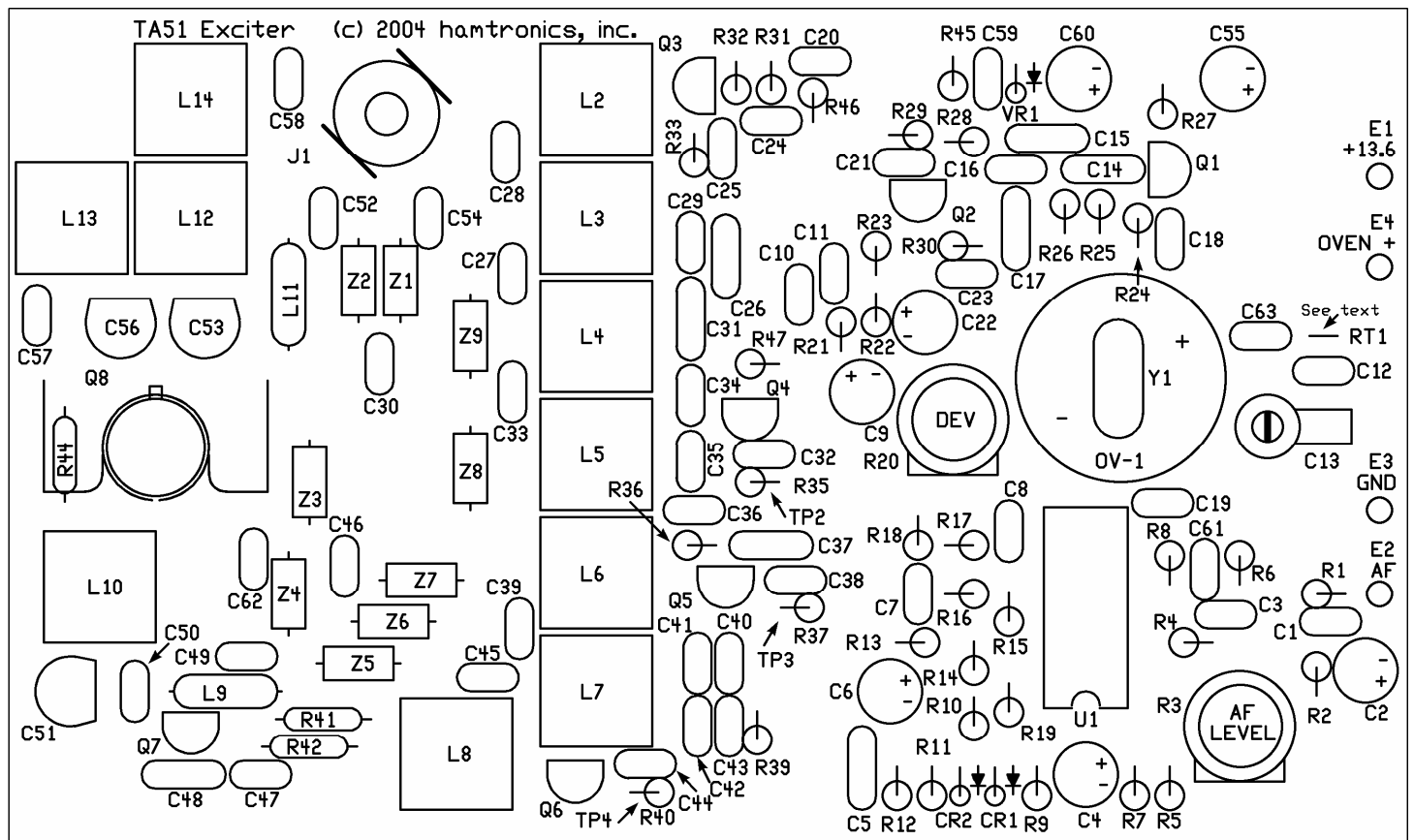

**PARTS LIST FOR TA51-144
[TA51-220] (REV A).**

Note: Capacitor values for 150-174 MHz may be slightly lower. Values which differ for the TA51-220 are shown in *[brackets]*. See sidebar for special values for the 160-173MHz sub-band.

❶ indicates surface mount part under board.

❷ Due to parts shortage, it is necessary to use two 6.8k resistors in series; join them at the top and tack solder leads together.

❸ Note: 0.5pf disc cap is no longer available. Carefully tack solder surface mount capacitor on bottom of board. Hold it carefully with tweezers to avoid dropping it.

Ref Desig	Value	(marking)
C1	680pf (681)	
C2	1 uf electrolytic	
C3	.01 uf disc (103)	
C4	4.7 uf electrolytic	
C5	470 pf (471)	
C6	1 uf electrolytic	
C7	470 pf (471)	
C8	39 pf	
C9	1 uf electrolytic	
C10-C11	.01uf disc (103)	
C12	43 pf	
C13	10 pf piston trimmer	
C14-C15	150 pf (151)	
C16	39 pf	
C17	150 pf (151)	
C18-C20	.01uf disc (103)	
C21	220 pf (221)	
C22	47 uF electrolytic	
C23	680pf (681) [100 pf]	
C24-C25	680pf (681)	
C26	110 pf (111)	
C27	680pf (681)	
C28	.01 uf disc (103)	
C29	2 pf	
C30	.0022 uf (2n2K or 2.2nK)	
C31	110 pf (111)	
C32-C33	680pf (681)	
C34	22 pf [8 pf]	
C35❸	0.5 pf chip cap	
C36	39 pf [12 pf]	
C37	62 pf [27 pf]	
C38	100pf (101)	
C39	680pf (681) [100 pf]	
C40	15 pf [5 pf]	

C41❸	0.5 pf chip cap
C42	27 pf [10 pf]
C43	39 pf [18 pf]
C44	100pf (101)
C45	680pf (681) [100 pf]
C46	.0022 uf (2n2K or 2.2nK)
C47	15 pf [4 pf]
C48	62 pf [33pf]
C49	100pf (101)
C50	10 pf [4 pf]
C51	30 pf green variable cap [20 pf pink variable cap]
C52	680pf (681) 100 pf]
C53	60 pf brown variable cap [20 pf pink variable cap]
C54	680pf (681) [100 pf]
C55	4.7 uF electrolytic
C56	30 pf green variable cap [11 pf blue variable cap]
C57	43 pf [15 pf]
C58	39 pf [20 pf]
C59	680pf (681) [100 pf]
C60	4.7 uF electrolytic
C61	39 pf
C62	.01 uf disc (103)
C63	not used
CR1-CR2	1N4148 (may be unmarked)
J1	RCA Jack
L1	not assigned
L2-L5	6-1/2 turns (blue)
L6-L8	2-1/2 turns (red)
L9	0.33 uH choke (red-sil-orn-orn)
L10	2-1/2 turns(red), no slug
L11	0.33 uH choke, (red-sil-orn-orn)
L12-L14	2-1/2 turns(red), no slug
Q1-Q6	2N5770
Q7	2N5770
Q8	BFQ-43S or MS1649
R1	2.2K
R2	100K
R3	1 meg pot (105)
R4	510K
R5	1 meg
R6	54K (2x 27K joined at top)
R7	1 meg
R8	510K
R9	1K
R10❶	10K
R11	1K
R12	68K
R13	100K
R14	1 meg
R15	510K
R16	330K

R17	510K
R18	150K
R19	680K
R20	20K pot (203) or 22K pot (223 or 22K)
R21-R22	4.7K
R23❶	10K [15K]
R24	100 ohms
R25❶	10K
R26	4.7K
R27	270 ohms
R28❷	13.6K (see note)
R29❶	10K
R30	2.2K
R31	27K
R32	4.7K
R33	270 ohms [180 ohms]
R34	not used
R35	270 ohms [100 ohms]
R36	3.3K
R37	100 ohms
R38	not used
R39	1K
R40	47 ohms
R41	2.2K
R42	27 ohms [100 ohms]
R43	not used
R44	27 ohms
R45	100 ohms
R46	2.2K
R47	2.2K
RT1	Thermistor (used only with TCXO option)
U1	3301 (can substitute 3401 or 3900)
VR1	1N5239B 9.1 V zener
Z1-Z9	Ferrite bead, prestrung

Special values for the 160-173MHz sub-band. Substitute these for standard values shown at left.

C26	82 pf
C31	82 pf
C34	20 pf
C36	33 pf
C40	10 pf
C42	22 pf
C43	27 pf
C47	10 pf
C48	47 pf
C57	33 pf
C58	27 pf

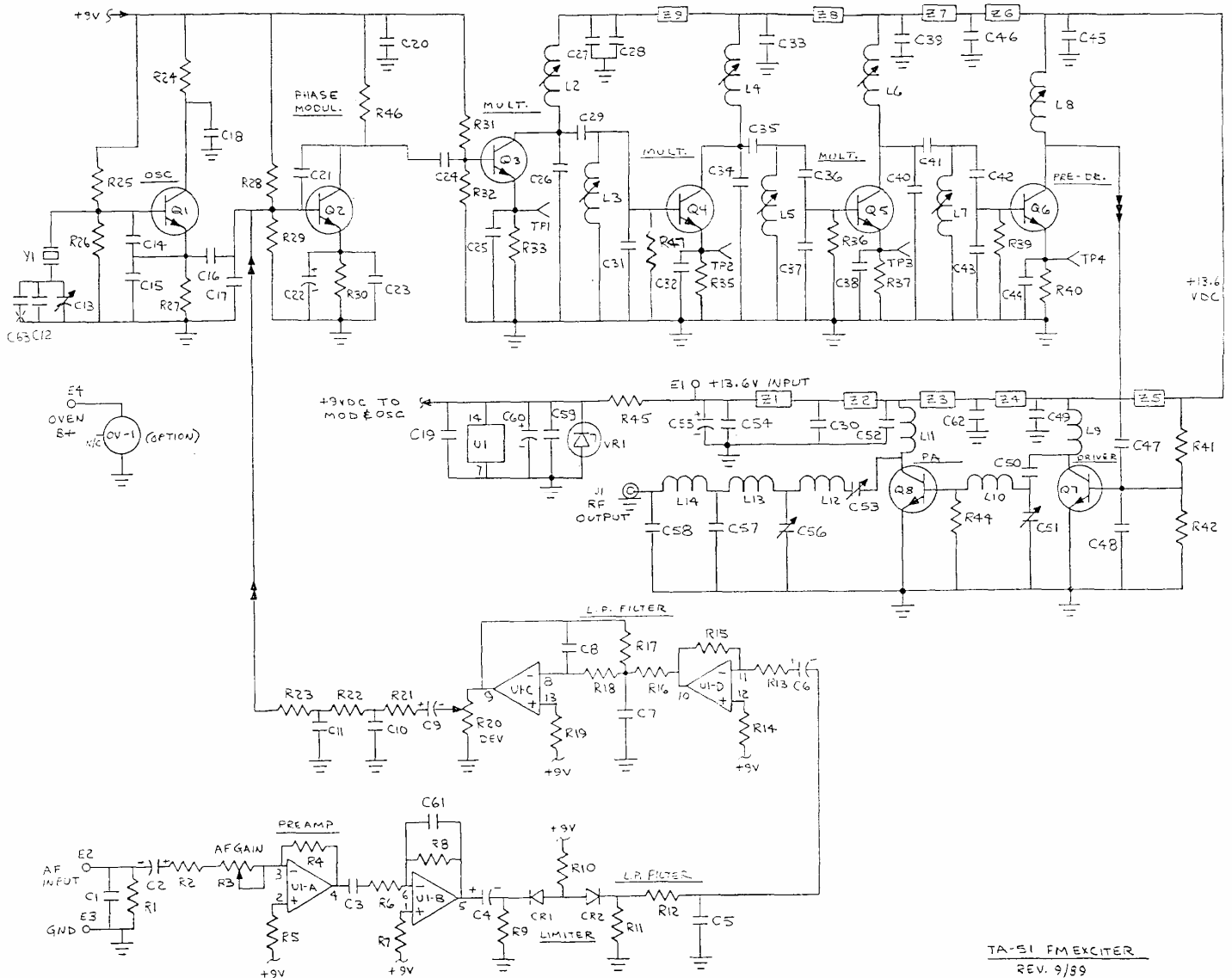

TA-51 FM EXCITER
REV. 9/59